

제일 트러스테크 구조 설계 편람

(Structural Design Manual for JEIL Trussdeck)

2001. 11.



社團 大韓建築學會
法人

제 출 문

(주)제일테크노스

대표이사 귀하

본 제일 트러스데크 설계 편람을 “제일 TRUSS DECK SLAB SYSTEM 개발에 관한 연구“의 최종 보고서로 제출합니다.

2001.10.

연구기관 : 대한건축학회
회장 정재철

▣ 편집위원 : 김상대 교수 (고려대학교, 공학박사)
김성수 교수 (청주대학교, 공학박사)
이원호 교수 (광운대학교, 공학박사)
홍갑표 교수 (연세대학교, 공학박사)
홍성걸 교수 (서울대학교, 공학박사)
이문곤 사장 (정일구조, 구조기술사)

▣ 자문위원 : 김 석 구 (3D구조, 구조기술사)
김 중 호 (창·민우구조, 구조기술사)
이 재 훈 (도화구조, 구조기술사)
정 광 량 (동양안전, 구조기술사)
차 승 렬 (동양구조, 구조기술사)

I. 트러스데크 설계 자료

1.	9
가.	트러스데크의 종류	9
나.	트러스데크의 구성	9
2.	10
가.	철근의 단면적 및 주장표	10
나.	철선의 공칭 선지름, 단면적 및 중량	12
다.	트러스재의 단면 성능표	14
라.	래티스재의 단면 성능표	26
마.	시공시 트러스데크의 허용 스펠	31
바.	사용시 트러스데크의 허용스팬	55
3.	81
가.	철골조의 설계 예 (L=2.8m)	81
나.	철근 콘크리트조의 설계 예 (L=3.3m)	89
다.	시공시 SUPPORT를 설치하는 경우의 설계 예 (L=4.7m)	79
라.	추가 보강근을 배근하는 경우의 설계 예 (L=2.7m)	110

II. 트러스테크의 구조 설계 및 시공 지침

1.	121
가.	적용 범위	121
나.	용어의 정의	121
다.	기호	123
2.	125
가.	철 선	125
나.	이형 철선	125
다.	이형 철선의 표준 길이	126
라.	이형 철선 길이의 허용차	126
마.	원형 철선	126
3.	128
가.	일반 사항	128
나.	형상 및 치수	128
다.	종 류	128
라.	허용차	130
마.	재료 시험	130
4.	132
가.	일반 사항	132
나.	구조 계획 및 해석	132
다.	설계 하중	133
5.	135

6.	137
가.	일반 사항	137
나.	시공시 단면 산정	137
7.	140
가.	일반 사항	140
나.	수축 및 온도 철근	140
다.	1방향 슬래브	141
라.	2방향 슬래브	145
마.	정착 및 이음	149
바.	슬래브의 개구부 보강	149
사.	배치 계획	149
8.	152
가.	일반사항	152
나.	시공 계획 및 관리	152
다.	트러스테크의 주문 및 생산	157
라.	트러스테크의 현장 반입 및 야적	161
마.	검 수	162
바.	야적 관리	164
9.	165
가.	양중 계획	165
나.	설 치	168
다.	트러스테크의 가공	170
라.	기타 부자재 및 배력 철근 배근	170

10.	172
가.	일반 사항	172
나.	콘크리트 타설 준비	172
다.	콘크리트 타설시 주의 사항	173

부록 I. "콘크리트 구조 설계 기준" 관련 규정

부록 II. "구조용 용접 철망" 관련 규정

부록 III. "한국 산업 규격" 관련 규정

부록 IV. PROGRAM MANUAL

I. 트러스데크 설계 자료

1. 트러스데크

가. 트러스데크의 종류

	상 부 철 선	하 부 철 선	LATTICE
A1-TYPE	1-D10	2-D 7	5
A2-TYPE	1-D12	2-D 8	
A3-TYPE	1-D14	2-D10	
A4-TYPE	1-D10	2-D 6	
A5-TYPE	1-D12	2-D 7	
A6-TYPE	1-D14	2-D 8	
A1a-TYPE	1-D10	2-D 7	6
A2a-TYPE	1-D12	2-D 8	
A3a-TYPE	1-D14	2-D10	
A4a-TYPE	1-D10	2-D 6	
A5a-TYPE	1-D12	2-D 7	
A6a-TYPE	1-D14	2-D 8	

나. 트러스데크의 구성

- ◆ DECK PLATE : 0.5t (KS-SGC570)
- ◆ LENGTH : 1,500~9,000 mm
- ◆ h : 70~280 mm
- ◆ : 200 mm
- ◆ : 5, 6, 7

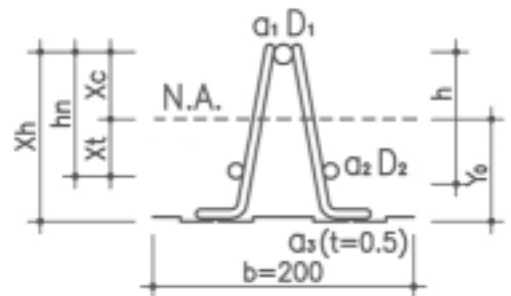

2. 트러스데크를 사용한 슬래브 설계자료

가. 철근의 단면적 및 주장표

(1) 원형 철근

(cm^2 , 가 cm)

호칭	중량 (kg/m)	1	2	3	4	5	6	7	8	9	10
φ4	0.099	0.13 1.26	0.25 2.51	0.38 3.77	0.50 5.02	0.63 6.28	0.75 7.53	0.88 8.78	1.01 10.04	1.13 11.30	1.26 12.55
φ5	0.154	0.20 1.57	0.39 3.14	0.59 4.71	0.79 6.28	0.98 7.86	1.18 9.43	1.37 11.00	1.57 12.57	1.77 14.14	1.96 15.71
φ6	0.222	0.28 1.88	0.56 3.76	0.85 5.64	1.13 7.52	1.41 9.40	1.69 11.28	1.98 13.16	2.25 15.04	2.54 16.92	2.82 18.80
φ7	0.302	0.38 2.20	0.77 4.40	1.15 6.60	1.54 8.80	1.92 11.00	2.31 13.20	2.69 15.40	3.08 17.60	3.46 19.79	3.85 21.99
φ8	0.395	0.50 2.51	1.00 5.02	1.51 7.53	2.01 10.04	2.51 12.55	3.01 15.05	3.51 17.55	4.01 20.08	4.51 22.60	5.02 25.10
φ9	0.499	0.64 2.83	1.27 5.65	1.91 8.48	2.54 11.31	3.18 14.14	3.82 16.96	4.45 19.79	5.09 22.62	5.73 25.45	6.36 28.27
φ12	0.888	1.13 3.77	2.26 7.54	3.39 11.31	4.52 15.08	5.65 18.65	6.79 22.62	7.91 26.39	9.05 30.16	10.18 33.93	11.31 37.70
φ13	1.040	1.33 4.08	2.65 8.17	3.98 12.25	5.31 16.34	6.64 20.42	7.96 24.50	9.29 28.60	10.62 32.67	11.95 36.75	13.27 40.84
φ14	1.210	1.54 4.40	3.08 8.80	4.62 13.20	6.16 17.59	7.70 21.99	9.24 26.39	10.78 30.79	12.32 35.19	13.86 39.59	15.39 43.98
φ16	1.580	2.01 5.03	4.02 10.05	6.03 15.08	8.04 20.11	10.05 25.13	12.00 30.16	14.07 35.19	16.08 40.21	18.09 45.24	20.11 50.27
φ19	2.230	2.84 5.97	5.87 11.94	8.51 17.91	11.34 23.98	14.18 29.85	17.02 35.81	19.85 41.78	22.68 47.75	25.52 53.72	28.35 59.69
φ22	2.980	3.80 6.91	7.60 13.82	11.40 20.73	15.21 29.65	19.01 34.56	22.81 41.47	26.61 48.38	30.41 55.29	34.21 62.20	38.01 69.12
φ25	3.850	4.91 7.85	9.82 15.71	14.73 23.56	19.63 31.42	24.54 39.27	29.45 47.12	34.36 54.98	39.27 62.83	44.18 70.69	49.08 78.54
φ28	4.830	8.16 8.80	12.31 17.59	18.47 26.39	24.63 35.19	30.79 43.98	36.94 52.78	43.10 61.58	49.26 70.37	55.42 79.17	61.58 87.92
φ32	6.310	8.04 10.05	16.08 20.11	24.13 30.16	32.17 40.21	40.21 50.27	48.26 60.32	56.30 70.37	64.34 80.42	72.38 90.48	80.42 100.7

(2) 이형 철근

(cm^2 , 가 cm)

호칭	중량 (kg/m)	1	2	3	4	5	6	7	8	9	10
D6	0.249	0.32 2.00	0.84 4.00	0.96 6.00	1.28 8.00	1.60 10.00	1.92 12.00	2.24 14.00	2.58 16.00	2.88 18.00	3.20 20.00
D8	0.389	0.50 2.50	0.99 5.00	1.49 7.50	1.98 10.00	2.48 12.50	2.97 15.00	3.47 17.50	3.96 20.00	4.48 22.50	4.85 25.00
D10	0.560	0.71 3.00	1.43 6.00	2.14 9.00	2.85 12.00	3.57 15.00	4.28 18.00	4.99 21.00	5.70 24.00	6.42 27.00	7.13 30.00
D13	0.995	1.27 4.00	2.54 8.00	3.81 12.00	5.08 16.00	6.35 20.00	7.82 24.00	8.89 28.00	10.16 32.00	11.43 36.00	12.70 40.00
D16	1.560	1.99 5.00	3.98 10.00	5.97 15.00	7.98 20.00	9.95 25.00	11.94 30.00	13.93 35.00	15.92 40.00	17.91 45.00	19.90 50.00
D19	2.250	2.87 6.00	5.74 12.00	8.61 18.00	11.48 24.00	14.35 30.00	17.22 36.00	20.09 42.00	22.98 48.00	25.83 54.00	28.70 60.00
D22	3.040	3.87 7.00	7.74 14.00	11.81 21.00	15.48 28.00	19.35 35.00	23.22 42.00	27.09 49.00	30.96 56.00	34.83 63.00	38.70 70.00
D25	3.980	5.07 8.00	10.14 16.00	15.21 24.00	20.28 32.00	25.35 40.00	30.42 48.00	35.49 56.00	40.56 64.00	45.63 72.00	50.70 80.00
D29	5.040	6.42 9.00	12.84 18.00	19.26 27.00	25.68 36.00	32.10 45.00	38.52 54.00	44.94 63.00	51.36 72.00	57.78 81.00	64.20 90.00
D32	6.230	7.94 10.00	15.88 20.00	23.82 30.00	31.76 40.00	39.70 50.00	47.64 60.00	55.58 70.00	63.52 80.00	71.46 90.00	79.40 100.0
D35	7.510	9.57 11.00	19.14 22.00	28.71 33.00	38.28 44.00	47.85 55.00	57.42 66.00	66.99 77.00	76.56 88.00	86.13 99.00	95.70 111.0
D38	8.950	11.40 12.00	22.80 24.00	34.20 36.00	45.60 48.00	57.00 60.00	68.40 72.00	79.80 84.00	91.20 96.00	102.6 108.0	114.0 120.0
D41	10.500	13.40 13.00	26.80 26.00	40.20 39.00	53.60 52.00	67.00 65.00	80.40 78.00	93.80 91.00	107.2 104.0	120.6 117.0	134.0 130.0

나. 철선의 공칭 선지름, 단면적 및 중량

(1) 원형 철선

호 칭	공칭 지름 (mm)	공칭 단면적 (cm^2)	공칭 중량 (kgf/m)	철선 간격에 따른 단면적(cm^2/m)						
				10	15	20	25	30	35	40
φ4	4.0	0.126	0.099	1.26	0.84	0.63	0.50	0.42	0.36	0.32
φ4.5	4.5	0.159	0.125	1.59	1.06	0.80	0.64	0.53	0.45	0.40
φ5	5.0	0.196	0.154	1.96	1.31	0.98	0.78	0.65	0.56	0.49
φ5.5	5.5	0.238	0.187	2.38	1.59	1.19	0.95	0.79	0.68	0.60
φ6	6.0	0.283	0.222	2.83	1.89	1.42	1.13	0.94	0.81	0.71
φ6.5	6.5	0.332	0.260	3.32	2.21	1.66	1.33	1.11	0.95	0.83
φ7	7.0	0.385	0.302	3.85	2.57	1.93	1.54	1.28	1.10	0.96
φ7.5	7.5	0.442	0.347	4.42	2.95	2.21	1.77	1.47	1.26	1.11
φ8	8.0	0.503	0.395	5.03	3.35	2.52	2.01	1.68	1.44	1.26
φ8.5	8.5	0.567	0.445	5.67	3.78	2.84	2.27	1.89	1.62	1.42
φ9	9.0	0.636	0.499	6.36	4.24	3.18	2.54	2.12	1.82	1.59
φ9.5	9.5	0.709	0.556	7.09	4.73	3.55	2.84	2.36	2.03	1.77
φ10	10.0	0.785	0.617	7.85	5.23	3.93	3.14	2.62	2.24	1.96
φ10.5	10.5	0.866	0.680	8.66	5.77	4.33	3.46	2.89	2.47	2.17
φ11	11.0	0.95	0.746	9.50	6.33	4.75	3.80	3.17	2.71	2.38
φ11.5	11.5	1.039	0.815	10.39	6.93	5.20	4.16	3.46	2.97	2.60
φ12	12.0	1.131	0.885	11.31	7.54	5.66	4.52	3.77	3.23	2.83
φ13	12.7	1.267	0.995	12.67	8.45	6.34	5.07	4.22	3.62	3.17
φ14	14.0	1.539	1.210	15.39	10.26	7.70	6.16	5.13	4.40	3.85
φ16	16.0	2.011	1.580	20.11	13.41	10.06	8.04	6.70	5.75	5.03

(2) 이형 철선

호 칭	공칭 지름 (mm)	공칭 단면적 (cm^2)	공칭 중량 (kgf/m)	철선 간격에 따른 단면적(cm^2/m)						
				10	15	20	25	30	35	40
D4	4.0	0.126	0.099	1.26	0.84	0.63	0.50	0.42	0.36	0.32
D4.5	4.5	0.159	0.125	1.59	1.06	0.80	0.64	0.53	0.45	0.40
D5	5.0	0.196	0.154	1.96	1.31	0.98	0.78	0.65	0.56	0.49
D5.5	5.5	0.238	0.187	2.38	1.59	1.19	0.95	0.79	0.68	0.60
D6	6.0	0.283	0.222	2.83	1.89	1.42	1.13	0.94	0.81	0.71
D6.5	6.5	0.332	0.260	3.32	2.21	1.66	1.33	1.11	0.95	0.83
D7	7.0	0.385	0.302	3.85	2.57	1.93	1.54	1.28	1.10	0.96
D7.5	7.5	0.442	0.347	4.42	2.95	2.21	1.77	1.47	1.26	1.11
D8	8.0	0.503	0.395	5.03	3.35	2.52	2.01	1.68	1.44	1.26
D8.5	8.5	0.567	0.445	5.67	3.78	2.84	2.27	1.89	1.62	1.42
D9	9.0	0.636	0.499	6.36	4.24	3.18	2.54	2.12	1.82	1.59
D9.5	9.5	0.709	0.556	7.09	4.73	3.55	2.84	2.36	2.03	1.77
D10	10.0	0.785	0.617	7.85	5.23	3.93	3.14	2.62	2.24	1.96
D10.5	10.5	0.866	0.680	8.66	5.77	4.33	3.46	2.89	2.47	2.17
D11	11.0	0.95	0.746	9.50	6.33	4.75	3.80	3.17	2.71	2.38
D11.5	11.5	1.039	0.815	10.39	6.93	5.20	4.16	3.46	2.97	2.60
D12	12.0	1.131	0.885	11.31	7.54	5.66	4.52	3.77	3.23	2.83
D13	12.7	1.267	0.995	12.67	8.45	6.34	5.07	4.22	3.62	3.17
D14	14.0	1.539	1.210	15.39	10.26	7.70	6.16	5.13	4.40	3.85
D16	16.0	2.011	1.580	20.11	13.41	10.06	8.04	6.70	5.75	5.03

다. 트러스재의 단면 성능표

A1-TYPE	<ul style="list-style-type: none"> • : 1-D10 ($a_1 = 0.79 \text{ cm}^2$) • : 2-D7 ($a_2 = 0.77 \text{ cm}^2$) • : $f_y = 5,000 \text{ kgf/cm}^2$ • TRUSS PITCH : 20cm • DECK PLATE m . 					
TYPE	h (mm)	X_c (cm)	X_t (cm)	I_o (cm^2/m)	Z_c (cm^3/m)	Z_t (cm^3/m)
A1-65	65	3.30	3.20	62.41	18.92	19.49
A1-70	70	3.55	3.45	73.87	20.84	21.38
A1-75	75	3.79	3.71	86.31	22.76	23.28
A1-80	80	4.04	3.96	99.72	24.68	25.19
A1-85	85	4.29	4.21	114.11	26.61	27.09
A1-90	90	4.54	4.46	129.46	28.54	29.00
A1-95	95	4.78	4.72	145.79	30.48	30.91
A1-100	100	5.03	4.97	163.08	32.42	32.82
A1-105	105	5.28	5.22	181.35	34.36	34.73
A1-110	110	5.53	5.47	200.59	36.30	36.65
A1-115	115	5.77	5.73	220.81	38.24	38.56
A1-120	120	6.02	5.98	241.99	40.19	40.48
A1-125	125	6.27	6.23	264.15	42.14	42.39
A1-130	130	6.52	6.48	287.28	44.09	44.31
A1-135	135	6.76	6.74	311.38	46.03	46.23
A1-140	140	7.01	6.99	336.45	47.98	48.14
A1-145	145	7.26	7.24	362.49	49.94	50.06
A1-150	150	7.51	7.49	389.51	51.89	51.98
A1-155	155	7.75	7.75	417.50	53.84	53.90
A1-160	160	8.00	8.00	446.46	55.79	55.82
A1-165	165	8.25	8.25	476.39	57.75	57.74
A1-170	170	8.50	8.50	507.29	59.70	59.66

A2-TYPE	<ul style="list-style-type: none"> • : 1-D12 ($a_1 = 1.13 \text{ cm}^2$) • : 2-D8 ($a_2 = 1.01 \text{ cm}^2$) • : $f_y = 5,000 \text{ kgf/cm}^2$ • TRUSS PITCH : 20cm • DECK PLATE m . 					
TYPE	h (mm)	X_c (cm)	X_t (cm)	I_o (cm^2/m)	Z_c (cm^3/m)	Z_t (cm^3/m)
A2- 65	65	3.19	3.31	81.24	25.47	24.54
A2- 70	70	3.42	3.58	96.55	28.19	27.00
A2- 75	75	3.66	3.84	113.18	30.93	29.47
A2- 80	80	3.90	4.10	131.15	33.67	31.95
A2- 85	85	4.13	4.37	150.45	36.42	34.43
A2- 90	90	4.37	4.63	171.09	39.19	36.92
A2- 95	95	4.60	4.90	193.05	41.95	39.41
A2-100	100	4.84	5.16	216.34	44.73	41.90
A2-105	105	5.07	5.43	240.97	47.51	44.39
A2-110	110	5.31	5.69	266.92	50.29	46.89
A2-115	115	5.54	5.96	294.21	53.08	49.39
A2-120	120	5.78	6.22	322.83	55.87	51.89
A2-125	125	6.01	6.49	352.77	58.66	54.39
A2-130	130	6.25	6.75	384.05	61.46	56.89
A2-135	135	6.48	7.02	416.66	64.26	59.39
A2-140	140	6.72	7.28	450.61	67.06	61.89
A2-145	145	6.96	7.54	485.88	69.86	64.40
A2-150	150	7.19	7.81	522.48	72.66	66.90
A2-155	155	7.43	8.07	560.42	75.47	69.41
A2-160	160	7.66	8.34	599.68	78.27	71.92
A2-165	165	7.90	8.60	640.28	81.08	74.42
A2-170	170	8.13	8.87	682.21	83.89	76.93

A2-TYPE	<ul style="list-style-type: none"> • : 1-D12 ($a_1 = 1.13 \text{ cm}^2$) • : 2-D8 ($a_2 = 1.01 \text{ cm}^2$) • : $f_y = 5,000 \text{ kgf/cm}^2$ • TRUSS PITCH : 20cm • DECK PLATE m . 					
TYPE	h (mm)	X_c (cm)	X_t (cm)	I_o (cm^2/m)	Z_c (cm^3/m)	Z_t (cm^3/m)
A2-175	175	8.37	9.13	725.47	86.70	79.44
A2-180	180	8.60	9.40	770.06	89.51	81.95
A2-185	185	8.84	9.66	815.98	92.32	84.45
A2-190	190	9.07	9.93	863.23	95.14	86.96
A2-195	195	9.31	10.19	911.82	97.95	89.47
A2-200	200	9.54	10.46	961.73	100.76	91.98
A2-205	205	9.78	10.72	1012.98	103.58	94.49
A2-210	210	10.02	10.98	1065.55	106.40	97.00
A2-215	215	10.25	11.25	1119.46	109.21	99.51
A2-220	220	10.49	11.51	1174.70	112.03	102.02
A2-225	225	10.72	11.78	1231.27	114.84	104.53
A2-230	230	10.96	12.04	1289.17	117.66	107.04
A2-235	235	11.19	12.31	1348.40	120.48	109.55
A2-240	240	11.43	12.57	1408.97	123.30	112.07
A2-245	245	11.66	12.84	1470.86	126.12	114.58
A2-250	250	11.90	13.10	1534.09	128.94	117.09
A2-255	255	12.13	13.37	1598.64	131.75	119.60
A2-260	260	12.37	13.63	1664.53	134.57	122.11
A2-265	265	12.60	13.90	1731.75	137.39	124.62
A2-270	270	12.84	14.16	1800.30	140.21	127.14
A2-275	275	13.07	14.43	1870.18	143.03	129.65
A2-280	280	13.31	14.69	1941.39	145.86	132.16

A3-TYPE	<ul style="list-style-type: none"> • : 1-D14 ($a_1 = 1.54 \text{ cm}^2$) • : 2-D10 ($a_2 = 1.57 \text{ cm}^2$) • : $f_y = 5,000 \text{ kgf/cm}^2$ • TRUSS PITCH : 20cm • DECK PLATE m . 					
TYPE	h (mm)	X_c (cm)	X_t (cm)	I_o (cm^2/m)	Z_c (cm^3/m)	Z_t (cm^3/m)
A3- 65	65	3.38	3.12	110.59	32.75	35.40
A3- 70	70	3.63	3.37	132.15	36.42	39.20
A3- 75	75	3.88	3.62	155.66	40.10	43.02
A3- 80	80	4.13	3.87	181.12	43.81	46.85
A3- 85	85	4.39	4.11	208.51	47.54	50.69
A3- 90	90	4.64	4.36	237.85	51.27	54.54
A3- 95	95	4.89	4.61	269.13	55.02	58.40
A3-100	100	5.14	4.86	302.36	58.78	62.26
A3-105	105	5.40	5.10	337.52	62.55	66.13
A3-110	110	5.65	5.35	374.63	66.32	70.01
A3-115	115	5.90	5.60	413.69	70.10	73.89
A3-120	120	6.15	5.85	454.68	73.89	77.77
A3-125	125	6.41	6.09	497.62	77.68	81.66
A3-130	130	6.66	6.34	542.50	81.47	85.55
A3-135	135	6.91	6.59	589.33	85.27	89.45
A3-140	140	7.16	6.84	638.09	89.07	93.34
A3-145	145	7.42	7.08	688.80	92.88	97.24
A3-150	150	7.67	7.33	741.46	96.68	101.14
A3-155	155	7.92	7.58	796.05	100.50	105.04
A3-160	160	8.17	7.83	852.59	104.31	108.94
A3-165	165	8.43	8.07	911.08	108.12	112.84
A3-170	170	8.68	8.32	971.50	111.94	116.75

A3-TYPE	<ul style="list-style-type: none"> • : 1-D14 ($a_1 = 1.54 \text{ cm}^2$) • : 2-D10 ($a_2 = 1.57 \text{ cm}^2$) • : $f_y = 5,000 \text{ kgf/cm}^2$ • TRUSS PITCH : 20cm • DECK PLATE m . 					
TYPE	h (mm)	X _c (cm)	X _t (cm)	I _o (cm ² /m)	Z _c (cm ³ /m)	Z _t (cm ³ /m)
A3-175	175	8.93	8.57	1033.87	115.76	120.66
A3-180	180	9.18	8.82	1098.18	119.58	124.56
A3-185	185	9.44	9.06	1164.43	123.40	128.47
A3-190	190	9.69	9.31	1232.63	127.22	132.38
A3-195	195	9.94	9.56	1302.77	131.05	136.29
A3-200	200	10.19	9.81	1374.85	134.87	140.20
A3-205	205	10.45	10.05	1448.88	138.70	144.11
A3-210	210	10.70	10.30	1524.85	142.53	148.02
A3-215	215	10.95	10.55	1602.76	146.35	151.94
A3-220	220	11.20	10.80	1682.61	150.18	155.85
A3-225	225	11.46	11.04	1764.41	154.01	159.76
A3-230	230	11.71	11.29	1848.15	157.84	163.68
A3-235	235	11.96	11.54	1933.83	161.68	167.59
A3-240	240	12.21	11.79	2021.46	165.51	171.51
A3-245	245	12.47	12.03	2111.03	169.34	175.42
A3-250	250	12.72	12.28	2202.54	173.17	179.34
A3-255	255	12.97	12.53	2296.00	177.01	183.26
A3-260	260	13.22	12.78	2391.40	180.84	187.17
A3-265	265	13.48	13.02	2488.74	184.68	191.09
A3-270	270	13.73	13.27	2588.02	188.51	195.01
A3-275	275	13.98	13.52	2689.25	192.35	198.93
A3-280	280	14.23	13.77	2792.42	196.18	202.84

A4-TYPE	<ul style="list-style-type: none"> • : 1-D10 ($a_1 = 0.79 \text{ cm}^2$) • : 2-D6 ($a_2 = 0.57 \text{ cm}^2$) • : $f_y = 5,000 \text{ kgf/cm}^2$ • TRUSS PITCH : 20cm • DECK PLATE m . 					
TYPE	h (mm)	X_c (cm)	X_t (cm)	I_o (cm^2/m)	Z_c (cm^3/m)	Z_t (cm^3/m)
A4-65	65	2.89	3.61	53.73	18.61	14.88
A4-70	70	3.10	3.90	63.52	20.51	16.28
A4-75	75	3.31	4.19	74.13	22.41	17.68
A4-80	80	3.52	4.48	85.55	24.33	19.08
A4-85	85	3.73	4.77	97.80	26.25	20.49
A4-90	90	3.94	5.06	110.88	28.17	21.89
A4-95	95	4.14	5.36	124.77	30.10	23.30
A4-100	100	4.35	5.65	139.49	32.03	24.71
A4-105	105	4.56	5.94	155.03	33.97	26.12
A4-110	110	4.77	6.23	171.39	35.91	27.52
A4-115	115	4.98	6.52	188.57	37.85	28.93
A4-120	120	5.19	6.81	206.58	39.79	30.34
A4-125	125	5.40	7.10	225.41	41.73	31.76
A4-130	130	5.61	7.39	245.06	43.67	33.17
A4-135	135	5.82	7.68	265.53	45.62	34.58
A4-140	140	6.03	7.97	286.82	47.57	35.99
A4-145	145	6.24	8.26	308.94	49.51	37.40
A4-150	150	6.45	8.55	331.88	51.46	38.81
A4-155	155	6.66	8.84	355.64	53.41	40.22
A4-160	160	6.87	9.13	380.23	55.36	41.64
A4-165	165	7.08	9.42	405.63	57.31	43.05
A4-170	170	7.29	9.71	431.86	59.26	44.46

A4-TYPE	<ul style="list-style-type: none"> • : 1-D10 ($a_1 = 0.79 \text{ cm}^2$) • : 2-D6 ($a_2 = 0.57 \text{ cm}^2$) • : $f_y = 5,000 \text{ kgf/cm}^2$ • TRUSS PITCH : 20cm • DECK PLATE m . 					
TYPE	h (mm)	X_c (cm)	X_t (cm)	I_o (cm^2/m)	Z_c (cm^3/m)	Z_t (cm^3/m)
A4-175	175	7.50	10.00	458.91	61.22	45.87
A4-180	180	7.71	10.29	486.78	63.17	47.29
A4-185	185	7.92	10.58	515.48	65.12	48.70
A4-190	190	8.12	10.88	544.99	67.08	50.11
A4-195	195	8.33	11.17	575.33	69.03	51.53
A4-200	200	8.54	11.46	606.49	70.99	52.94
A4-205	205	8.75	11.75	638.47	72.94	54.35
A4-210	210	8.96	12.04	671.28	74.90	55.77
A4-215	215	9.17	12.33	704.91	76.85	57.18
A4-220	220	9.38	12.62	739.36	78.81	58.59
A4-225	225	9.59	12.91	774.63	80.76	60.01
A4-230	230	9.80	13.20	810.72	82.72	61.42
A4-235	235	10.01	13.49	847.64	84.68	62.84
A4-240	240	10.22	13.78	885.38	86.64	64.25
A4-245	245	10.43	14.07	923.94	88.59	65.66
A4-250	250	10.64	14.36	963.32	90.55	67.08
A4-255	255	10.85	14.65	1003.53	92.51	68.49
A4-260	260	11.06	14.94	1044.55	94.47	69.90
A4-265	265	11.27	15.23	1086.40	96.42	71.32
A4-270	270	11.48	15.52	1129.07	98.38	72.73
A4-275	275	11.69	15.81	1172.57	100.34	74.15
A4-280	280	11.90	16.10	1216.88	102.30	75.56

A5-TYPE	<ul style="list-style-type: none"> • : 1-D12 ($a_1 = 1.13 \text{ cm}^2$) • : 2-D7 ($a_2 = 0.77 \text{ cm}^2$) • : $f_y = 5,000 \text{ kgf/cm}^2$ • TRUSS PITCH : 20cm • DECK PLATE m . 					
TYPE	h (mm)	X_c (cm)	X_t (cm)	I_o (cm^2/m)	Z_c (cm^3/m)	Z_t (cm^3/m)
A5-65	65	2.85	3.65	71.18	24.99	19.49
A5-70	70	3.05	3.95	84.47	27.69	21.39
A5-75	75	3.25	4.25	98.90	30.40	23.29
A5-80	80	3.46	4.54	114.47	33.13	25.19
A5-85	85	3.66	4.84	131.19	35.86	27.10
A5-90	90	3.86	5.14	149.06	38.61	29.00
A5-95	95	4.06	5.44	168.07	41.36	30.91
A5-100	100	4.27	5.73	188.23	44.13	32.83
A5-105	105	4.47	6.03	209.53	46.89	34.74
A5-110	110	4.67	6.33	231.98	49.67	36.65
A5-115	115	4.87	6.63	255.57	52.44	38.57
A5-120	120	5.08	6.92	280.31	55.22	40.48
A5-125	125	5.28	7.22	306.19	58.01	42.40
A5-130	130	5.48	7.52	333.22	60.80	44.32
A5-135	135	5.68	7.82	361.40	63.59	46.23
A5-140	140	5.89	8.11	390.71	66.38	48.15
A5-145	145	6.09	8.41	421.18	69.18	50.07
A5-150	150	6.29	8.71	452.79	71.97	51.99
A5-155	155	6.49	9.01	485.54	74.77	53.91
A5-160	160	6.70	9.30	519.44	77.58	55.83
A5-165	165	6.90	9.60	554.49	80.38	57.75
A5-170	170	7.10	9.90	590.68	83.18	59.67

A5-TYPE	<ul style="list-style-type: none"> • : 1-D12 ($a_1 = 1.13 \text{ cm}^2$) • : 2-D7 ($a_2 = 0.77 \text{ cm}^2$) • : $f_y = 5,000 \text{ kgf/cm}^2$ • TRUSS PITCH : 20cm • DECK PLATE m . 					
TYPE	h (mm)	X_c (cm)	X_t (cm)	I_o (cm^2/m)	Z_c (cm^3/m)	Z_t (cm^3/m)
A5-175	175	7.30	10.20	628.02	85.99	61.59
A5-180	180	7.51	10.49	666.50	88.79	63.51
A5-185	185	7.71	10.79	706.12	91.60	65.43
A5-190	190	7.91	11.09	746.90	94.41	67.36
A5-195	195	8.11	11.39	788.81	97.22	69.28
A5-200	200	8.32	11.68	831.88	100.03	71.20
A5-205	205	8.52	11.98	876.08	102.84	73.12
A5-210	210	8.72	12.28	921.44	105.65	75.04
A5-215	215	8.92	12.58	967.93	108.47	76.97
A5-220	220	9.13	12.87	1015.58	111.28	78.89
A5-225	225	9.33	13.17	1064.37	114.09	80.81
A5-230	230	9.53	13.47	1114.30	116.91	82.73
A5-235	235	9.73	13.77	1165.38	119.72	84.66
A5-240	240	9.94	14.06	1217.61	122.54	86.58
A5-245	245	10.14	14.36	1270.98	125.36	88.50
A5-250	250	10.34	14.66	1325.49	128.17	90.42
A5-255	255	10.54	14.96	1381.15	130.99	92.35
A5-260	260	10.75	15.25	1437.96	133.81	94.27
A5-265	265	10.95	15.55	1495.91	136.62	96.19
A5-270	270	11.15	15.85	1555.00	139.44	98.12
A5-275	275	11.35	16.15	1615.25	142.26	100.04
A5-280	280	11.56	16.44	1676.63	145.08	101.96

A6-TYPE	<ul style="list-style-type: none"> • : 1-D14 ($a_1 = 1.13 \text{ cm}^2$) • : 2-D8 ($a_2 = 1.01 \text{ cm}^2$) • : $f_y = 5,000 \text{ kgf/cm}^2$ • TRUSS PITCH : 20cm • DECK PLATE m . 					
TYPE	h (mm)	X_c (cm)	X_t (cm)	I_o (cm^2/m)	Z_c (cm^3/m)	Z_t (cm^3/m)
A6-65	65	2.83	3.67	89.84	31.69	24.51
A6-70	70	3.03	3.97	107.03	35.30	26.97
A6-75	75	3.23	4.27	125.73	38.93	29.44
A6-80	80	3.43	4.57	145.96	42.59	31.92
A6-85	85	3.63	4.87	167.71	46.26	34.40
A6-90	90	3.82	5.18	190.98	49.96	36.89
A6-95	95	4.02	5.48	215.77	53.67	39.38
A6-100	100	4.22	5.78	242.08	57.39	41.87
A6-105	105	4.42	6.08	269.91	61.13	44.36
A6-110	110	4.61	6.39	299.26	64.87	46.86
A6-115	115	4.81	6.69	330.14	68.62	49.35
A6-120	120	5.01	6.99	362.53	72.38	51.85
A6-125	125	5.21	7.29	396.45	76.15	54.35
A6-130	130	5.40	7.60	431.88	79.92	56.86
A6-135	135	5.60	7.90	468.84	83.70	59.36
A6-140	140	5.80	8.20	507.32	87.48	61.86
A6-145	145	6.00	8.50	547.31	91.27	64.37
A6-150	150	6.19	8.81	588.83	95.06	66.87
A6-155	155	6.39	9.11	631.87	98.85	69.38
A6-160	160	6.59	9.41	676.44	102.65	71.88
A6-165	165	6.79	9.71	722.52	106.45	74.39
A6-170	170	6.99	10.01	770.12	110.25	76.90

A6-TYPE	<ul style="list-style-type: none"> • : 1-D14 ($a_1 = 1.13 \text{ cm}^2$) • : 2-D8 ($a_2 = 1.01 \text{ cm}^2$) • : $f_y = 5,000 \text{ kgf/cm}^2$ • TRUSS PITCH : 20cm • DECK PLATE m . 					
TYPE	h (mm)	X _c (cm)	X _t (cm)	I _o (cm ² /m)	Z _c (cm ³ /m)	Z _t (cm ³ /m)
A6-175	175	7.18	10.32	819.24	114.06	79.40
A6-180	180	7.38	10.62	869.89	117.87	81.91
A6-185	185	7.58	10.92	922.05	121.68	84.42
A6-190	190	7.78	11.22	975.74	125.49	86.93
A6-195	195	7.97	11.53	1030.95	129.30	89.44
A6-200	200	8.17	11.83	1087.68	133.12	91.95
A6-205	205	8.37	12.13	1145.92	136.93	94.46
A6-210	210	8.57	12.43	1205.69	140.75	96.97
A6-215	215	8.76	12.74	1266.98	144.57	99.48
A6-220	220	8.96	13.04	1329.80	148.39	101.99
A6-225	225	9.16	13.34	1394.13	152.21	104.50
A6-230	230	9.36	13.64	1459.98	156.04	107.01
A6-235	235	9.55	13.95	1527.36	159.86	109.52
A6-240	240	9.75	14.25	1596.25	163.68	112.03
A6-245	245	9.95	14.55	1666.67	167.51	114.54
A6-250	250	10.15	14.85	1738.60	171.34	117.06
A6-255	255	10.34	15.16	1812.06	175.16	119.57
A6-260	260	10.54	15.46	1887.04	178.99	122.08
A6-265	265	10.74	15.76	1963.54	182.82	124.59
A6-270	270	10.94	16.06	2041.56	186.65	127.10
A6-275	275	11.14	16.36	2121.10	190.48	129.62
A6-280	280	11.33	16.67	2202.16	194.31	132.13

라. 래티스재의 단면 성능표

(1) 허용 압축 응력도

Ⓐ 세장비() :

$$= \frac{l_k}{i}$$

$$\rho = \sqrt{\frac{2 \cdot E}{0.6 F_y}} \quad (\quad)$$

Ⓑ 허용 압축 응력도 (${}_s f_c$) :

$${}_s f_c = \left\{ 1 - 0.4 \left(\frac{\quad}{\rho} \right)^2 \right\} \cdot \frac{f_y}{n} \quad (\quad \rho)$$

$${}_s f_c = \frac{0.277 \cdot f_y}{\left(\frac{\quad}{\rho} \right)^2} \quad (> \rho)$$

$$n = \frac{3}{2} + \frac{2}{3} \left(\frac{\quad}{\rho} \right)^2$$

래티스 Φ5		<ul style="list-style-type: none"> $A = 0.196 \text{ cm}^2$ $I_0 = 0.00307 \text{ cm}^4$ $i = 0.125 \text{ cm}$ $\rho = 83$ $f_y = 5,000 \text{ kgf/cm}^2$ 											
트러스데크		A1		A2		A3		A4		A5		A6	
TYP E	h (mm)	I_k	$s f_c$	I_k	$s f_c$	I_k	$s f_c$	I_k	$s f_c$	I_k	$s f_c$	I_k	$s f_c$
A-65	65	11.5	1.13	11.4	1.15	11.3	1.17	11.5	1.13	11.4	1.14	11.4	1.15
A-70	70	11.7	1.08	11.7	1.10	11.6	1.12	11.8	1.08	11.7	1.09	11.6	1.11
A-75	75	12.0	1.04	11.9	1.05	11.8	1.07	12.0	1.03	12.0	1.05	11.9	1.06
A-80	80	12.3	0.99	12.2	1.00	12.1	1.02	12.3	0.98	12.2	1.00	12.1	1.01
A-85	85	12.6	0.94	12.5	0.96	12.4	0.98	12.6	0.94	12.5	0.95	12.4	0.97
A-90	90	12.9	0.90	12.8	0.91	12.7	0.93	12.9	0.89	12.8	0.91	12.7	0.92
A-95	95	13.2	0.86	13.1	0.87	13.0	0.89	13.3	0.85	13.2	0.86	13.1	0.88
A-100	100	13.6	0.81	13.5	0.83	13.3	0.84	13.6	0.81	13.5	0.82	13.4	0.83
A-105	105	13.9	0.77	13.8	0.79	13.7	0.80	13.9	0.77	13.8	0.78	13.7	0.79
A-110	110	14.2	0.74	14.1	0.75	14.0	0.76	14.3	0.73	14.2	0.74	14.1	0.76
A-115	115	14.6	0.70	14.5	0.71	14.4	0.73	14.6	0.70	14.5	0.71	14.4	0.72
A-120	120	15.0	0.67	14.9	0.68	14.7	0.69	15.0	0.66	14.9	0.67	14.8	0.68
A-125	125	15.4	0.63	15.2	0.64	15.1	0.66	15.4	0.63	15.3	0.64	15.2	0.65
A-130	130	15.7	0.60	15.6	0.61	15.5	0.62	15.8	0.60	15.7	0.61	15.5	0.62
A-135	135	16.1	0.57	16.0	0.58	15.9	0.59	16.2	0.57	16.0	0.58	15.9	0.59
A-140	140	16.5	0.55	16.4	0.56	16.2	0.57	16.6	0.55	16.4	0.55	16.3	0.56
A-145	145	16.9	0.52	16.8	0.53	16.6	0.54	17.0	0.52	16.8	0.53	16.7	0.53
A-150	150	17.3	0.50	17.2	0.51	17.0	0.51	17.4	0.50	17.2	0.50	17.1	0.51
A-155	155	17.7	0.48	17.6	0.48	17.4	0.49	17.8	0.47	17.7	0.48	17.5	0.49
A-160	160	18.2	0.45	18.0	0.46	17.9	0.47	18.2	0.45	18.1	0.46	17.9	0.46
A-165	165	18.6	0.43	18.4	0.44	18.3	0.45	18.6	0.43	18.5	0.44	18.4	0.44
A-170	170	19.0	0.41	18.9	0.42	18.7	0.43	19.0	0.41	18.9	0.42	18.8	0.42

래티스 Φ5		<ul style="list-style-type: none"> $A = 0.196 \text{ cm}^2$ $I_0 = 0.00307 \text{ cm}^4$ $i = 0.125 \text{ cm}$ $\rho = 83$ $f_y = 5,000 \text{ kgf/cm}^2$ 											
트러스데크		A1		A2		A3		A4		A5		A6	
TYP E	h (mm)	I_k	$s f_c$	I_k	$s f_c$	I_k	$s f_c$	I_k	$s f_c$	I_k	$s f_c$	I_k	$s f_c$
A-175	175	19.4	0.40	19.3	0.40	19.1	0.41	19.5	0.39	19.3	0.40	19.2	0.41
A-180	180	19.9	0.38	19.7	0.38	19.6	0.39	19.9	0.38	19.8	0.38	19.6	0.39
A-185	185	20.3	0.36	20.2	0.37	20.0	0.37	20.3	0.36	20.2	0.37	20.1	0.37
A-190	190	20.7	0.35	20.6	0.35	20.4	0.36	20.8	0.35	20.6	0.35	20.5	0.36
A-195	195	21.2	0.33	21.0	0.34	20.9	0.34	21.2	0.33	21.1	0.34	20.9	0.34
A-200	200	21.6	0.32	21.5	0.32	21.3	0.33	21.6	0.32	21.5	0.32	21.4	0.33
A-205	205	22.0	0.31	21.9	0.31	21.7	0.32	22.1	0.31	22.0	0.31	21.8	0.31
A-210	210	22.5	0.30	22.4	0.30	22.2	0.30	22.5	0.29	22.4	0.30	22.3	0.30
A-215	215	22.9	0.28	22.8	0.29	22.6	0.29	23.0	0.28	22.9	0.29	22.7	0.29
A-220	220	23.4	0.27	23.3	0.28	23.1	0.28	23.4	0.27	23.3	0.28	23.2	0.28
A-225	225	23.8	0.26	23.7	0.27	23.5	0.27	23.9	0.26	23.8	0.26	23.6	0.27
A-230	230	24.3	0.25	24.2	0.26	24.0	0.26	24.3	0.25	24.2	0.26	24.1	0.26
A-235	235	24.8	0.24	24.6	0.25	24.4	0.25	24.8	0.24	24.7	0.25	24.5	0.25
A-240	240	25.2	0.24	25.1	0.24	24.9	0.24	25.3	0.23	25.1	0.24	25.0	0.24
A-245	245	25.7	0.23	25.5	0.23	25.4	0.23	25.7	0.23	25.6	0.23	25.4	0.23
A-250	250	26.1	0.22	26.0	0.22	25.8	0.22	26.2	0.22	26.0	0.22	25.9	0.22
A-255	255	26.6	0.21	26.5	0.21	26.3	0.22	26.6	0.21	26.5	0.21	26.4	0.22
A-260	260	27.1	0.20	26.9	0.21	26.7	0.21	27.1	0.20	27.0	0.21	26.8	0.21
A-265	265	27.5	0.20	27.4	0.20	27.2	0.20	27.6	0.20	27.4	0.20	27.3	0.20
A-270	270	28.0	0.19	27.9	0.19	27.7	0.20	28.0	0.19	27.9	0.19	27.8	0.19
A-275	275	28.5	0.18	28.3	0.19	28.1	0.19	28.5	0.18	28.4	0.19	28.2	0.19
A-280	280	28.9	0.18	28.8	0.18	28.6	0.18	29.0	0.18	28.8	0.18	28.7	0.18

래티스 Φ6		<ul style="list-style-type: none"> $A = 0.280 \text{ cm}^2$ $I_0 = 0.00636 \text{ cm}^4$ $i = 0.150 \text{ cm}$ $\rho = 83$ $f_y = 5,000 \text{ kgf/cm}^2$ 											
트러스데크		A1		A2		A3		A4		A5		A6	
TYP E	h (mm)	I_k	$s f_c$	I_k	$s f_c$	I_k	$s f_c$	I_k	$s f_c$	I_k	$s f_c$	I_k	$s f_c$
A-65	65	11.5	1.60	11.4	1.61	11.3	1.64	11.5	1.49	11.4	1.50	11.4	1.51
A-70	70	11.7	1.54	11.7	1.56	11.6	1.58	11.8	1.45	11.7	1.46	11.6	1.47
A-75	75	12.0	1.48	11.9	1.50	11.8	1.53	12.0	1.41	12.0	1.42	11.9	1.43
A-80	80	12.3	1.42	12.2	1.44	12.1	1.47	12.3	1.36	12.2	1.37	12.1	1.39
A-85	85	12.6	1.36	12.5	1.38	12.4	1.40	12.6	1.31	12.5	1.33	12.4	1.34
A-90	90	12.9	1.29	12.8	1.31	12.7	1.34	12.9	1.26	12.8	1.28	12.7	1.29
A-95	95	13.2	1.23	13.1	1.25	13.0	1.27	13.3	1.21	13.2	1.23	13.1	1.24
A-100	100	13.6	1.17	13.5	1.19	13.3	1.21	13.6	1.16	13.5	1.18	13.4	1.19
A-105	105	13.9	1.11	13.8	1.13	13.7	1.15	13.9	1.11	13.8	1.13	13.7	1.14
A-110	110	14.2	1.06	14.1	1.08	14.0	1.10	14.3	1.06	14.2	1.07	14.1	1.09
A-115	115	14.6	1.01	14.5	1.02	14.4	1.04	14.6	1.00	14.5	1.02	14.4	1.03
A-120	120	15.0	0.96	14.9	0.97	14.7	0.99	15.0	0.95	14.9	0.97	14.8	0.98
A-125	125	15.4	0.91	15.2	0.93	15.1	0.95	15.4	0.91	15.3	0.92	15.2	0.94
A-130	130	15.7	0.87	15.6	0.88	15.5	0.90	15.8	0.87	15.7	0.88	15.5	0.89
A-135	135	16.1	0.83	16.0	0.84	15.9	0.86	16.2	0.82	16.0	0.84	15.9	0.85
A-140	140	16.5	0.79	16.4	0.80	16.2	0.82	16.6	0.79	16.4	0.80	16.3	0.81
A-145	145	16.9	0.75	16.8	0.76	16.6	0.78	17.0	0.75	16.8	0.76	16.7	0.77
A-150	150	17.3	0.72	17.2	0.73	17.0	0.74	17.4	0.71	17.2	0.72	17.1	0.73
A-155	155	17.7	0.68	17.6	0.69	17.4	0.71	17.8	0.68	17.7	0.69	17.5	0.70
A-160	160	18.2	0.65	18.0	0.66	17.9	0.67	18.2	0.65	18.1	0.66	17.9	0.67
A-165	165	18.6	0.62	18.4	0.63	18.3	0.64	18.6	0.62	18.5	0.63	18.4	0.64
A-170	170	19.0	0.60	18.9	0.60	18.7	0.62	19.0	0.59	18.9	0.60	18.8	0.61

래 티 스 Φ6		<ul style="list-style-type: none"> • $A = 0.280 \text{ cm}^2$ $I_0 = 0.00636 \text{ cm}^4$ • $i = 0.150 \text{ cm}$ $\rho = 83$ • $f_y = 5,000 \text{ kgf/cm}^2$ 											
트러스데크		A1		A2		A3		A4		A5		A6	
TYP E	h (mm)	I_k	$s f_c$	I_k	$s f_c$	I_k	$s f_c$	I_k	$s f_c$	I_k	$s f_c$	I_k	$s f_c$
A-175	175	19.4	0.57	19.3	0.58	19.1	0.59	19.5	0.57	19.3	0.58	19.2	0.58
A-180	180	19.9	0.55	19.7	0.55	19.6	0.56	19.9	0.54	19.8	0.55	19.6	0.56
A-185	185	20.3	0.52	20.2	0.53	20.0	0.54	20.3	0.52	20.2	0.53	20.1	0.53
A-190	190	20.7	0.50	20.6	0.51	20.4	0.52	20.8	0.50	20.6	0.51	20.5	0.51
A-195	195	21.2	0.48	21.0	0.49	20.9	0.50	21.2	0.48	21.1	0.48	20.9	0.49
A-200	200	21.6	0.46	21.5	0.47	21.3	0.47	21.6	0.46	21.5	0.47	21.4	0.47
A-205	205	22.0	0.44	21.9	0.45	21.7	0.46	22.1	0.44	22.0	0.45	21.8	0.45
A-210	210	22.5	0.43	22.4	0.43	22.2	0.44	22.5	0.42	22.4	0.43	22.3	0.43
A-215	215	22.9	0.41	22.8	0.41	22.6	0.42	23.0	0.41	22.9	0.41	22.7	0.42
A-220	220	23.4	0.39	23.3	0.40	23.1	0.40	23.4	0.39	23.3	0.40	23.2	0.40
A-225	225	23.8	0.38	23.7	0.38	23.5	0.39	23.9	0.38	23.8	0.38	23.6	0.39
A-230	230	24.3	0.36	24.2	0.37	24.0	0.37	24.3	0.36	24.2	0.37	24.1	0.37
A-235	235	24.8	0.35	24.6	0.36	24.4	0.36	24.8	0.35	24.7	0.35	24.5	0.36
A-240	240	25.2	0.34	25.1	0.34	24.9	0.35	25.3	0.34	25.1	0.34	25.0	0.34
A-245	245	25.7	0.33	25.5	0.33	25.4	0.33	25.7	0.33	25.6	0.33	25.4	0.33
A-250	250	26.1	0.32	26.0	0.32	25.8	0.32	26.2	0.31	26.0	0.32	25.9	0.32
A-255	255	26.6	0.30	26.5	0.31	26.3	0.31	26.6	0.30	26.5	0.31	26.4	0.31
A-260	260	27.1	0.29	26.9	0.30	26.7	0.30	27.1	0.29	27.0	0.30	26.8	0.30
A-265	265	27.5	0.28	27.4	0.29	27.2	0.29	27.6	0.28	27.4	0.29	27.3	0.29
A-270	270	28.0	0.27	27.9	0.28	27.7	0.28	28.0	0.27	27.9	0.28	27.8	0.28
A-275	275	28.5	0.27	28.3	0.27	28.1	0.27	28.5	0.26	28.4	0.27	28.2	0.27
A-280	280	28.9	0.26	28.8	0.26	28.6	0.26	29.0	0.26	28.8	0.26	28.7	0.26

마. 시공시 트러스데크의 허용 스패

철근콘크리트조			시공시 트러스데크의 허용 스패					
A1 - TYPE			<ul style="list-style-type: none"> • $f_{ck}=210\text{ kgf/cm}^2$ • $f_y=5,000\text{ kgf/cm}^2$ • : 2.0 cm • : 2.5 cm • TRUSS PITCH : 200 mm 					
LATTICE		5 1-D10 2-D7 30.0cm	SUPPORT		CAMBER			2-Span
TYPE	h (mm)	SLAB THK. (mm)	SUPPORT	NONE	1.0cm	L/200	L/250	
A1- 65	65	120	C 3850	D 2450	D 2850	C 2900	D 2900	-
A1- 70	70	125	C 3950	D 2500	D 2950	C 2950	C 2950	-
A1- 75	75	130	C 4000	D 2600	D 3050	C 3050	C 3050	-
A1- 80	80	135	C 4050	D 2650	D 3100	C 3100	C 3100	-
A1- 85	85	140	C 4150	D 2700	C 3150	C 3150	C 3150	-
A1- 90	90	145	C 4200	D 2800	C 3200	C 3200	C 3200	-
A1- 95	95	150	C 4250	D 2850	C 3200	C 3200	C 3200	-
A1-100	100	155	C 4300	D 2900	C 3250	C 3250	C 3250	-
A1-105	105	160	C 4350	D 2950	C 3300	C 3300	C 3300	-
A1-110	110	165	C 4400	D 3000	C 3350	C 3350	C 3350	-
A1-115	115	170	C 4450	D 3050	C 3350	C 3350	C 3350	-
A1-120	120	175	C 4450	D 3100	C 3400	C 3400	C 3400	-
A1-125	125	180	C 4500	D 3150	C 3400	C 3400	C 3400	-
A1-130	130	185	C 4550	D 3150	L 3400	L 3400	L 3400	-
A1-135	135	190	C 4550	D 3200	L 3250	L 3250	L 3250	-
A1-140	140	195	C 4600	L 3050	L 3050	L 3050	L 3050	-
A1-145	145	200	L 4350	L 2900	L 2900	L 2900	L 2900	-
A1-150	150	205	L 4100	L 2750	L 2750	L 2750	L 2750	-
A1-155	155	210	L 3850	L 2600	L 2600	L 2600	L 2600	-
A1-160	160	215	L 3650	L 2450	L 2450	L 2450	L 2450	-
A1-165	165	220	L 3450	L 2350	L 2350	L 2350	L 2350	-
A1-170	170	225	L 3250	L 2200	L 2200	L 2200	L 2200	-
A1-175	175	230	L 3050	L 2100	L 2100	L 2100	L 2100	-
A1-180	180	235	L 2900	L 2000	L 2000	L 2000	L 2000	-
A1-185	185	240	L 2700	L 1900	L 1900	L 1900	L 1900	-
A1-190	190	245	L 2550	L 1800	L 1800	L 1800	L 1800	-
A1-195	195	250	L 2400	L 1700	L 1700	L 1700	L 1700	-

Note - D : Deflection, C : Compression, T : Tension, L : Lattice (79p.)

철근콘크리트조			시공시 트러스데크의 허용 스펠					
A2 - TYPE			<ul style="list-style-type: none"> • $f_{ck}=210\text{ kgf/cm}^2$ • $f_y=5,000\text{ kgf/cm}^2$ • : 2.0 cm • : 2.5 cm • TRUSS PITCH : 200 mm 					
LATTICE		5 1-D12 2-D8 30.0cm	SUPPORT		CAMBER			2-Span
TYPE	h (mm)	SLAB THK. (mm)	SUPP.	NONE	1.0cm	L/200	L/250	
A2- 65	65	120	C 4950	D 2600	D 3050	D 3200	D 3100	-
A2- 70	70	125	C 5050	D 2700	D 3150	D 3350	D 3200	-
A2- 75	75	130	C 5150	D 2750	D 3250	D 3450	D 3350	-
A2- 80	80	135	C 5250	D 2850	D 3350	D 3550	D 3450	-
A2- 85	85	140	C 5350	D 2900	D 3400	D 3700	D 3550	-
A2- 90	90	145	C 5450	D 2950	D 3500	D 3800	D 3650	-
A2- 95	95	150	C 5500	D 3050	D 3550	D 3900	D 3750	-
A2-100	100	155	C 5550	D 3100	D 3650	D 4000	D 3800	-
A2-105	105	160	C 5650	D 3150	D 3700	D 4050	D 3900	-
A2-110	110	165	C 5700	D 3200	D 3750	D 4150	D 4000	-
A2-115	115	170	C 5750	D 3250	D 3850	L 4050	L 4050	-
A2-120	120	175	C 5800	D 3300	L 3800	L 3800	L 3800	-
A2-125	125	180	L 5550	D 3350	L 3650	L 3650	L 3650	-
A2-130	130	185	L 5250	D 3400	L 3450	L 3450	L 3450	-
A2-135	135	190	L 4950	L 3250	L 3250	L 3250	L 3250	-
A2-140	140	195	L 4650	L 3100	L 3100	L 3100	L 3100	-
A2-145	145	200	L 4400	L 2900	L 2900	L 2900	L 2900	-
A2-150	150	205	L 4150	L 2750	L 2750	L 2750	L 2750	-
A2-155	155	210	L 3900	L 2600	L 2600	L 2600	L 2600	-
A2-160	160	215	L 3700	L 2500	L 2500	L 2500	L 2500	-
A2-165	165	220	L 3500	L 2350	L 2350	L 2350	L 2350	-
A2-170	170	225	L 3300	L 2250	L 2250	L 2250	L 2250	-
A2-175	175	230	L 3100	L 2100	L 2100	L 2100	L 2100	-
A2-180	180	235	L 2900	L 2000	L 2000	L 2000	L 2000	-
A2-185	185	240	L 2750	L 1900	L 1900	L 1900	L 1900	-
A2-190	190	245	L 2600	L 1800	L 1800	L 1800	L 1800	-
A2-195	195	250	L 2450	L 1700	L 1700	L 1700	L 1700	-

Note - D : Deflection, C : Compression, T : Tension, L : Lattice (79p.)

철근콘크리트조			시공시 트러스데크의 허용 스패					
A3 - TYPE			<ul style="list-style-type: none"> • $f_{ck}=210\text{kgf/cm}^2$ • $f_y=5,000\text{kgf/cm}^2$ • : 2.0 cm • : 2.5 cm • TRUSS PITCH : 200 mm 					
LATTICE		5 1-D14 2-D10 30.0cm	SUPPORT		CAMBER			2-Span
TYPE	h (mm)	SLAB THK. (mm)	SUPP.	NONE	1.0cm	L/200	L/250	
A3- 65	65	120	D 6500	D 2800	D 3300	D 3500	D 3350	-
A3- 70	70	125	D 6750	D 2900	D 3400	D 3650	D 3500	-
A3- 75	75	130	D 7000	D 2950	D 3500	D 3800	D 3650	-
A3- 80	80	135	D 7200	D 3050	D 3600	D 3900	D 3750	-
A3- 85	85	140	D 7400	D 3150	D 3700	D 4050	D 3900	-
A3- 90	90	145	D 7550	D 3200	D 3800	D 4150	D 4000	-
A3- 95	95	150	L 7600	D 3300	D 3850	D 4250	D 4100	-
A3-100	100	155	L 7250	D 3350	D 3950	D 4400	D 4200	-
A3-105	105	160	L 6950	D 3400	D 4000	D 4500	D 4300	-
A3-110	110	165	L 6600	D 3450	D 4100	L 4300	L 4300	-
A3-115	115	170	L 6250	D 3550	L 4050	L 4050	L 4050	-
A3-120	120	175	L 5950	D 3600	L 3850	L 3850	L 3850	-
A3-125	125	180	L 5600	D 3650	L 3650	L 3650	L 3650	-
A3-130	130	185	L 5300	L 3500	L 3500	L 3500	L 3500	-
A3-135	135	190	L 5000	L 3300	L 3300	L 3300	L 3300	-
A3-140	140	195	L 4750	L 3150	L 3150	L 3150	L 3150	-
A3-145	145	200	L 4450	L 2950	L 2950	L 2950	L 2950	-
A3-150	150	205	L 4200	L 2800	L 2800	L 2800	L 2800	-
A3-155	155	210	L 3950	L 2650	L 2650	L 2650	L 2650	-
A3-160	160	215	L 3750	L 2500	L 2500	L 2500	L 2500	-
A3-165	165	220	L 3550	L 2400	L 2400	L 2400	L 2400	-
A3-170	170	225	L 3350	L 2250	L 2250	L 2250	L 2250	-
A3-175	175	230	L 3150	L 2150	L 2150	L 2150	L 2150	-
A3-180	180	235	L 2950	L 2050	L 2050	L 2050	L 2050	-
A3-185	185	240	L 2800	L 1900	L 1900	L 1900	L 1900	-
A3-190	190	245	L 2600	L 1800	L 1800	L 1800	L 1800	-
A3-195	195	250	L 2450	L 1750	L 1750	L 1750	L 1750	-

Note - D : Deflection, C : Compression, T : Tension, L : Lattice (79p.)

철근콘크리트조			시공시 트러스데크의 허용 스패					
A4 - TYPE			<ul style="list-style-type: none"> • $f_{ck}=210\text{kgf/cm}^2$ • $f_y=5,000\text{kgf/cm}^2$ • : 2.0 cm • : 2.5 cm • TRUSS PITCH : 200 mm 					
LATTICE		5 1-D10 2-D6 30.0cm	SUPPORT		CAMBER			2-Span
TYPE	h (mm)	SLAB THK. (mm)	SUPP.	NONE	1.0cm	L/200	L/250	
A4- 65	65	120	C 2850	D 2350	D 2750	D 2850	D 2800	-
A4- 70	70	125	C 2900	D 2450	D 2850	D 2950	D 2900	-
A4- 75	75	130	C 2950	D 2500	D 2950	C 3050	D 2950	-
A4- 80	80	135	C 3000	D 2550	D 3000	C 3100	D 3050	-
A4- 85	85	140	C 3050	D 2600	D 3100	C 3150	D 3150	-
A4- 90	90	145	C 3100	D 2700	D 3150	C 3200	C 3200	-
A4- 95	95	150	C 3150	D 2750	D 3200	C 3250	C 3250	-
A4-100	100	155	C 3150	D 2800	C 3250	C 3250	C 3250	-
A4-105	105	160	C 3200	D 2850	C 3300	C 3300	C 3300	-
A4-110	110	165	C 3250	D 2900	C 3350	C 3350	C 3350	-
A4-115	115	170	C 3250	D 2950	C 3350	C 3350	C 3350	-
A4-120	120	175	C 3300	D 2950	C 3400	C 3400	C 3400	-
A4-125	125	180	C 3300	D 3000	C 3400	C 3400	C 3400	-
A4-130	130	185	C 3350	D 3050	L 3400	L 3400	L 3400	-
A4-135	135	190	C 3350	D 3100	L 3200	L 3200	L 3200	-
A4-140	140	195	C 3350	L 3050	L 3050	L 3050	L 3050	-
A4-145	145	200	C 3400	L 2900	L 2900	L 2900	L 2900	-
A4-150	150	205	C 3400	L 2750	L 2750	L 2750	L 2750	-
A4-155	155	210	C 3400	L 2600	L 2600	L 2600	L 2600	-
A4-160	160	215	C 3450	L 2450	L 2450	L 2450	L 2450	-
A4-165	165	220	C 3450	L 2300	L 2300	L 2300	L 2300	-
A4-170	170	225	L 3250	L 2200	L 2200	L 2200	L 2200	-
A4-175	175	230	L 3050	L 2100	L 2100	L 2100	L 2100	-
A4-180	180	235	L 2850	L 1950	L 1950	L 1950	L 1950	-
A4-185	185	240	L 2700	L 1850	L 1850	L 1850	L 1850	-
A4-190	190	245	L 2550	L 1750	L 1750	L 1750	L 1750	-
A4-195	195	250	L 2400	L 1700	L 1700	L 1700	L 1700	-

Note - D : Deflection, C : Compression, T : Tension, L : Lattice (79p.)

철근콘크리트조			시공시 트러스데크의 허용 스펠					
A5 - TYPE			<ul style="list-style-type: none"> • $f_{ck}=210\text{kgf/cm}^2$ • $f_y=5,000\text{kgf/cm}^2$ • : 2.0 cm • : 2.5 cm • TRUSS PITCH : 200 mm 					
LATTICE		5 1-D12 2-D7 30.0cm	SUPPORT		CAMBER			2-Span
TYPE	h (mm)	SLAB THK. (mm)	SUPP.	NONE	1.0cm	L/200	L/250	
A5- 65	65	120	C 3800	D 2500	D 2950	D 3100	D 3000	-
A5- 70	70	125	C 3900	D 2600	D 3050	D 3200	D 3100	-
A5- 75	75	130	C 4000	D 2650	D 3150	D 3350	D 3200	-
A5- 80	80	135	C 4050	D 2750	D 3200	D 3450	D 3300	-
A5- 85	85	140	C 4100	D 2800	D 3300	D 3550	D 3400	-
A5- 90	90	145	C 4150	D 2850	D 3400	D 3650	D 3500	-
A5- 95	95	150	C 4250	D 2950	D 3450	D 3750	D 3600	-
A5-100	100	155	C 4300	D 3000	D 3500	D 3800	D 3700	-
A5-105	105	160	C 4350	D 3050	D 3600	D 3900	D 3750	-
A5-110	110	165	C 4350	D 3100	D 3650	T 3950	D 3850	-
A5-115	115	170	C 4400	D 3150	D 3700	T 4000	D 3900	-
A5-120	120	175	C 4450	D 3200	D 3750	L 3800	L 3800	-
A5-125	125	180	C 4500	D 3250	L 3600	L 3600	L 3600	-
A5-130	130	185	C 4500	D 3300	L 3450	L 3450	L 3450	-
A5-135	135	190	C 4550	L 3250	L 3250	L 3250	L 3250	-
A5-140	140	195	C 4600	L 3100	L 3100	L 3100	L 3100	-
A5-145	145	200	L 4400	L 2900	L 2900	L 2900	L 2900	-
A5-150	150	205	L 4150	L 2750	L 2750	L 2750	L 2750	-
A5-155	155	210	L 3900	L 2600	L 2600	L 2600	L 2600	-
A5-160	160	215	L 3700	L 2450	L 2450	L 2450	L 2450	-
A5-165	165	220	L 3450	L 2350	L 2350	L 2350	L 2350	-
A5-170	170	225	L 3250	L 2200	L 2200	L 2200	L 2200	-
A5-175	175	230	L 3100	L 2100	L 2100	L 2100	L 2100	-
A5-180	180	235	L 2900	L 2000	L 2000	L 2000	L 2000	-
A5-185	185	240	L 2750	L 1900	L 1900	L 1900	L 1900	-
A5-190	190	245	L 2550	L 1800	L 1800	L 1800	L 1800	-
A5-195	195	250	L 2400	L 1700	L 1700	L 1700	L 1700	-

Note - D : Deflection, C : Compression, T : Tension, L : Lattice (79p.)

철근콘크리트조			시공시 트러스데크의 허용 스펠					
A6 - TYPE			<ul style="list-style-type: none"> • $f_{ck}=210\text{kgf/cm}^2$ • $f_y=5,000\text{kgf/cm}^2$ • : 2.0 cm • : 2.5 cm • TRUSS PITCH : 200 mm 					
LATTICE		5 1-D14 2-D8 30.0cm	SUPPORT		CAMBER			2-Span
TYPE	h (mm)	SLAB THK. (mm)	SUPP.	NONE	1.0cm	L/200	L/250	
A6- 65	65	120	C 4900	D 2650	D 3100	D 3300	D 3200	-
A6- 70	70	125	C 5000	D 2750	D 3200	D 3450	D 3300	-
A6- 75	75	130	C 5100	D 2800	D 3300	D 3550	D 3450	-
A6- 80	80	135	C 5200	D 2900	D 3400	D 3700	D 3550	-
A6- 85	85	140	C 5300	D 2950	D 3500	D 3800	D 3650	-
A6- 90	90	145	C 5400	D 3050	D 3600	D 3900	D 3750	-
A6- 95	95	150	C 5450	D 3100	D 3650	D 4000	D 3850	-
A6-100	100	155	C 5550	D 3150	D 3750	D 4100	D 3950	-
A6-105	105	160	C 5600	D 3250	D 3800	D 4200	D 4050	-
A6-110	110	165	C 5650	D 3300	D 3900	L 4250	D 4150	-
A6-115	115	170	C 5750	D 3350	D 3950	L 4050	L 4050	-
A6-120	120	175	C 5800	D 3400	L 3850	L 3850	L 3850	-
A6-125	125	180	L 5550	D 3450	L 3650	L 3650	L 3650	-
A6-130	130	185	L 5250	L 3450	L 3450	L 3450	L 3450	-
A6-135	135	190	L 5000	L 3300	L 3300	L 3300	L 3300	-
A6-140	140	195	L 4700	L 3100	L 3100	L 3100	L 3100	-
A6-145	145	200	L 4450	L 2950	L 2950	L 2950	L 2950	-
A6-150	150	205	L 4200	L 2800	L 2800	L 2800	L 2800	-
A6-155	155	210	L 3950	L 2650	L 2650	L 2650	L 2650	-
A6-160	160	215	L 3700	L 2500	L 2500	L 2500	L 2500	-
A6-165	165	220	L 3500	L 2350	L 2350	L 2350	L 2350	-
A6-170	170	225	L 3300	L 2250	L 2250	L 2250	L 2250	-
A6-175	175	230	L 3100	L 2100	L 2100	L 2100	L 2100	-
A6-180	180	235	L 2950	L 2000	L 2000	L 2000	L 2000	-
A6-185	185	240	L 2750	L 1900	L 1900	L 1900	L 1900	-
A6-190	190	245	L 2600	L 1800	L 1800	L 1800	L 1800	-
A6-195	195	250	L 2450	L 1700	L 1700	L 1700	L 1700	-

Note - D : Deflection, C : Compression, T : Tension, L : Lattice (79p.)

철근콘크리트조			시공시 트러스데크의 허용 스패						
A1a - TYPE			<ul style="list-style-type: none"> • $f_{ck}=210\text{kgf/cm}^2$ • $f_y=5,000\text{kgf/cm}^2$ • : 2.0 cm • : 2.5 cm • TRUSS PITCH : 200 mm 						
LATTICE		6 1-D10 2-D7 30.0cm	SLAB THK. (mm)		SUPPORT		CAMBER		2-Span
TYPE	h (mm)		SUPP.	NONE	1.0cm	L/200	L/250		
A1a- 65	65	120	C 3850	D 2450	D 2850	C 2900	D 2900	-	
A1a- 70	70	125	C 3950	D 2500	D 2950	C 2950	C 2950	-	
A1a- 75	75	130	C 4000	D 2600	D 3050	C 3050	C 3050	-	
A1a- 80	80	135	C 4050	D 2650	D 3100	C 3100	C 3100	-	
A1a- 85	85	140	C 4150	D 2700	C 3150	C 3150	C 3150	-	
A1a- 90	90	145	C 4200	D 2800	C 3200	C 3200	C 3200	-	
A1a- 95	95	150	C 4250	D 2850	C 3200	C 3200	C 3200	-	
A1a-100	100	155	C 4300	D 2900	C 3250	C 3250	C 3250	-	
A1a-105	105	160	C 4350	D 2950	C 3300	C 3300	C 3300	-	
A1a-110	110	165	C 4400	D 3000	C 3350	C 3350	C 3350	-	
A1a-115	115	170	C 4450	D 3050	C 3350	C 3350	C 3350	-	
A1a-120	120	175	C 4450	D 3100	C 3400	C 3400	C 3400	-	
A1a-125	125	180	C 4500	D 3150	C 3400	C 3400	C 3400	-	
A1a-130	130	185	C 4550	D 3150	C 3450	C 3450	C 3450	-	
A1a-135	135	190	C 4550	D 3200	C 3450	C 3450	C 3450	-	
A1a-140	140	195	C 4600	D 3250	C 3500	C 3500	C 3500	-	
A1a-145	145	200	C 4650	D 3300	C 3500	C 3500	C 3500	-	
A1a-150	150	205	C 4650	D 3300	C 3550	C 3550	C 3550	-	
A1a-155	155	210	C 4700	D 3350	C 3550	C 3550	C 3550	-	
A1a-160	160	215	C 4700	D 3400	C 3550	C 3550	C 3550	-	
A1a-165	165	220	C 4700	D 3450	C 3600	C 3600	C 3600	-	
A1a-170	170	225	C 4750	D 3450	C 3600	C 3600	C 3600	-	
A1a-175	175	230	C 4750	D 3500	C 3600	C 3600	C 3600	-	
A1a-180	180	235	C 4800	D 3500	C 3650	C 3650	C 3650	-	
A1a-185	185	240	C 4800	D 3550	C 3650	C 3650	C 3650	-	
A1a-190	190	245	C 4800	D 3600	L 3600	L 3600	L 3600	-	
A1a-195	195	250	C 4800	L 3400	L 3400	L 3400	L 3400	-	

Note - D : Deflection, C : Compression, T : Tension, L : Lattice (79p.)

철근콘크리트조			시공시 트러스데크의 허용 스펠					
A2a - TYPE			<ul style="list-style-type: none"> • $f_{ck}=210\text{ kgf/cm}^2$ • $f_y=5,000\text{ kgf/cm}^2$ • : 2.0 cm • : 2.5 cm • TRUSS PITCH : 200 mm 					
LATTICE		6 1-D12 2-D8 30.0cm	SUPPORT		CAMBER			2-Span
TYPE	h (mm)	SLAB THK. (mm)	SUPP.	NONE	1.0cm	L/200	L/250	
A2a- 65	65	120	C 4950	D 2600	D 3050	D 3200	D 3100	-
A2a- 70	70	125	C 5050	D 2700	D 3150	D 3350	D 3200	-
A2a- 75	75	130	C 5150	D 2750	D 3250	D 3450	D 3350	-
A2a- 80	80	135	C 5250	D 2850	D 3350	D 3550	D 3450	-
A2a- 85	85	140	C 5350	D 2900	D 3400	D 3700	D 3550	-
A2a- 90	90	145	C 5450	D 2950	D 3500	D 3800	D 3650	-
A2a- 95	95	150	C 5500	D 3050	D 3550	D 3900	D 3750	-
A2a-100	100	155	C 5550	D 3100	D 3650	D 4000	D 3800	-
A2a-105	105	160	C 5650	D 3150	D 3700	D 4050	D 3900	-
A2a-110	110	165	C 5700	D 3200	D 3750	D 4150	D 4000	-
A2a-115	115	170	C 5750	D 3250	D 3850	D 4250	D 4100	-
A2a-120	120	175	C 5800	D 3300	D 3900	D 4350	D 4150	-
A2a-125	125	180	C 5850	D 3350	D 3950	D 4400	D 4250	-
A2a-130	130	185	C 5900	D 3400	D 4000	D 4500	D 4300	-
A2a-135	135	190	C 5950	D 3450	D 4050	D 4550	D 4350	-
A2a-140	140	195	C 6000	D 3500	D 4100	D 4650	D 4450	-
A2a-145	145	200	C 6050	D 3550	D 4150	D 4700	D 4500	-
A2a-150	150	205	C 6050	D 3550	D 4200	C 4750	D 4550	-
A2a-155	155	210	C 6100	D 3600	D 4250	C 4800	D 4650	-
A2a-160	160	215	C 6150	D 3650	D 4300	C 4800	D 4700	-
A2a-165	165	220	C 6150	D 3700	D 4350	L 4750	D 4750	-
A2a-170	170	225	C 6200	D 3700	D 4400	L 4500	L 4500	-
A2a-175	175	230	C 6250	D 3750	L 4250	L 4250	L 4250	-
A2a-180	180	235	L 6200	D 3800	L 4050	L 4050	L 4050	-
A2a-185	185	240	L 5850	D 3800	L 3850	L 3850	L 3850	-
A2a-190	190	245	L 5550	L 3650	L 3650	L 3650	L 3650	-
A2a-195	195	250	L 5250	L 3450	L 3450	L 3450	L 3450	-

Note - D : Deflection, C : Compression, T : Tension, L : Lattice (79p.)

철근콘크리트조			시공시 트러스데크의 허용 스패						
A3a - TYPE			<ul style="list-style-type: none"> • $f_{ck}=210\text{kgf/cm}^2$ • $f_y=5,000\text{kgf/cm}^2$ • : 2.0 cm • : 2.5 cm • TRUSS PITCH : 200 mm 						
LATTICE		6 1-D14 2-D10 30.0cm	SLAB THK. (mm)		SUPPORT		CAMBER		2-Span
TYPE	h (mm)		SUPP.	NONE	1.0cm	L/200	L/250		
A3a- 65	65	120	D 6500	D 2800	D 3300	D 3500	D 3350	-	
A3a- 70	70	125	D 6750	D 2900	D 3400	D 3650	D 3500	-	
A3a- 75	75	130	D 7000	D 2950	D 3500	D 3800	D 3650	-	
A3a- 80	80	135	D 7200	D 3050	D 3600	D 3900	D 3750	-	
A3a- 85	85	140	D 7400	D 3150	D 3700	D 4050	D 3900	-	
A3a- 90	90	145	D 7550	D 3200	D 3800	D 4150	D 4000	-	
A3a- 95	95	150	D 7750	D 3300	D 3850	D 4250	D 4100	-	
A3a-100	100	155	D 7900	D 3350	D 3950	D 4400	D 4200	-	
A3a-105	105	160	D 7950	D 3400	D 4000	D 4500	D 4300	-	
A3a-110	110	165	D 7950	D 3450	D 4100	D 4600	D 4400	-	
A3a-115	115	170	D 7950	D 3550	D 4150	D 4700	D 4500	-	
A3a-120	120	175	D 7950	D 3600	D 4250	D 4800	D 4600	-	
A3a-125	125	180	D 7950	D 3650	D 4300	D 4900	D 4650	-	
A3a-130	130	185	D 7950	D 3700	D 4350	D 4950	D 4750	-	
A3a-135	135	190	D 7950	D 3750	D 4400	D 5050	D 4850	-	
A3a-140	140	195	D 7950	D 3800	D 4500	D 5150	D 4900	-	
A3a-145	145	200	D 7950	D 3850	D 4550	D 5200	D 5000	-	
A3a-150	150	205	D 7950	D 3900	D 4600	D 5300	D 5050	-	
A3a-155	155	210	D 7950	D 3950	D 4650	D 5400	D 5150	-	
A3a-160	160	215	L 7900	D 3950	D 4700	L 5100	L 5100	-	
A3a-165	165	220	L 7450	D 4000	D 4750	L 4850	L 4850	-	
A3a-170	170	225	L 7050	D 4050	L 4550	L 4550	L 4550	-	
A3a-175	175	230	L 6650	D 4100	L 4350	L 4350	L 4350	-	
A3a-180	180	235	L 6300	L 4100	L 4100	L 4100	L 4100	-	
A3a-185	185	240	L 5950	L 3900	L 3900	L 3900	L 3900	-	
A3a-190	190	245	L 5600	L 3700	L 3700	L 3700	L 3700	-	
A3a-195	195	250	L 5300	L 3500	L 3500	L 3500	L 3500	-	

Note - D : Deflection, C : Compression, T : Tension, L : Lattice (79p.)

철근콘크리트조			시공시 트러스데크의 허용 스패					
A4a - TYPE			<ul style="list-style-type: none"> • $f_{ck}=210\text{ kgf/cm}^2$ • $f_y=5,000\text{ kgf/cm}^2$ • : 2.0 cm • : 2.5 cm • TRUSS PITCH : 200 mm 					
LATTICE		6 1-D10 2-D6 30.0cm	SUPPORT		CAMBER			2-Span
TYPE	h (mm)	SLAB THK. (mm)	SUPP.	NONE	1.0cm	L/200	L/250	
A4a- 65	65	120	C 2850	D 2350	D 2750	D 2850	D 2800	-
A4a- 70	70	125	C 2900	D 2450	D 2850	D 2950	D 2900	-
A4a- 75	75	130	C 2950	D 2500	D 2950	C 3050	D 2950	-
A4a- 80	80	135	C 3000	D 2550	D 3000	C 3100	D 3050	-
A4a- 85	85	140	C 3050	D 2600	D 3100	C 3150	D 3150	-
A4a- 90	90	145	C 3100	D 2700	D 3150	C 3200	C 3200	-
A4a- 95	95	150	C 3150	D 2750	D 3200	C 3250	C 3250	-
A4a-100	100	155	C 3150	D 2800	C 3250	C 3250	C 3250	-
A4a-105	105	160	C 3200	D 2850	C 3300	C 3300	C 3300	-
A4a-110	110	165	C 3250	D 2900	C 3350	C 3350	C 3350	-
A4a-115	115	170	C 3250	D 2950	C 3350	C 3350	C 3350	-
A4a-120	120	175	C 3300	D 2950	C 3400	C 3400	C 3400	-
A4a-125	125	180	C 3300	D 3000	C 3400	C 3400	C 3400	-
A4a-130	130	185	C 3350	D 3050	C 3450	C 3450	C 3450	-
A4a-135	135	190	C 3350	D 3100	C 3450	C 3450	C 3450	-
A4a-140	140	195	C 3350	D 3150	C 3500	C 3500	C 3500	-
A4a-145	145	200	C 3400	D 3150	C 3500	C 3500	C 3500	-
A4a-150	150	205	C 3400	D 3200	C 3550	C 3550	C 3550	-
A4a-155	155	210	C 3400	D 3250	C 3550	C 3550	C 3550	-
A4a-160	160	215	C 3450	D 3250	C 3550	C 3550	C 3550	-
A4a-165	165	220	C 3450	D 3300	C 3600	C 3600	C 3600	-
A4a-170	170	225	C 3450	D 3350	C 3600	C 3600	C 3600	-
A4a-175	175	230	C 3450	D 3350	C 3600	C 3600	C 3600	-
A4a-180	180	235	C 3500	D 3400	C 3650	C 3650	C 3650	-
A4a-185	185	240	C 3500	D 3400	C 3650	C 3650	C 3650	-
A4a-190	190	245	C 3500	D 3450	L 3600	L 3600	L 3600	-
A4a-195	195	250	C 3500	L 3400	L 3400	L 3400	L 3400	-

Note - D : Deflection, C : Compression, T : Tension, L : Lattice (79p.)

철근콘크리트조			시공시 트러스데크의 허용 스패						
A5a - TYPE			<ul style="list-style-type: none"> • $f_{ck}=210\text{kgf/cm}^2$ • $f_y=5,000\text{kgf/cm}^2$ • : 2.0 cm • : 2.5 cm • TRUSS PITCH : 200 mm 						
LATTICE		6 1-D12 2-D7 30.0cm	SLAB THK. (mm)		SUPPORT		CAMBER		2-Span
TYPE	h (mm)		SUPP.	NONE	1.0cm	L/200	L/250		
A5a- 65	65	120	C 3800	D 2500	D 2950	D 3100	D 3000	-	
A5a- 70	70	125	C 3900	D 2600	D 3050	D 3200	D 3100	-	
A5a- 75	75	130	C 4000	D 2650	D 3150	D 3350	D 3200	-	
A5a- 80	80	135	C 4050	D 2750	D 3200	D 3450	D 3300	-	
A5a- 85	85	140	C 4100	D 2800	D 3300	D 3550	D 3400	-	
A5a- 90	90	145	C 4150	D 2850	D 3400	D 3650	D 3500	-	
A5a- 95	95	150	C 4250	D 2950	D 3450	D 3750	D 3600	-	
A5a-100	100	155	C 4300	D 3000	D 3500	D 3800	D 3700	-	
A5a-105	105	160	C 4350	D 3050	D 3600	D 3900	D 3750	-	
A5a-110	110	165	C 4350	D 3100	D 3650	T 3950	D 3850	-	
A5a-115	115	170	C 4400	D 3150	D 3700	T 4000	D 3900	-	
A5a-120	120	175	C 4450	D 3200	D 3750	T 4050	D 4000	-	
A5a-125	125	180	C 4500	D 3250	D 3800	T 4050	D 4050	-	
A5a-130	130	185	C 4500	D 3300	D 3900	T 4100	T 4100	-	
A5a-135	135	190	C 4550	D 3350	D 3950	T 4150	T 4150	-	
A5a-140	140	195	C 4600	D 3350	D 4000	T 4150	T 4150	-	
A5a-145	145	200	C 4600	D 3400	D 4050	T 4200	T 4200	-	
A5a-150	150	205	C 4650	D 3450	D 4100	T 4200	T 4200	-	
A5a-155	155	210	C 4650	D 3500	D 4100	T 4250	T 4250	-	
A5a-160	160	215	C 4700	D 3500	D 4150	T 4250	T 4250	-	
A5a-165	165	220	C 4700	D 3550	D 4200	T 4300	T 4300	-	
A5a-170	170	225	C 4750	D 3600	D 4250	T 4300	T 4300	-	
A5a-175	175	230	C 4750	D 3600	L 4250	L 4250	L 4250	-	
A5a-180	180	235	C 4750	D 3650	L 4050	L 4050	L 4050	-	
A5a-185	185	240	C 4800	D 3700	L 3850	L 3850	L 3850	-	
A5a-190	190	245	C 4800	L 3650	L 3650	L 3650	L 3650	-	
A5a-195	195	250	C 4800	L 3450	L 3450	L 3450	L 3450	-	

Note - D : Deflection, C : Compression, T : Tension, L : Lattice (79p.)

철근콘크리트조			시공시 트러스데크의 허용 스패					
A6a - TYPE			<ul style="list-style-type: none"> • $f_{ck}=210\text{kgf/cm}^2$ • $f_y=5,000\text{kgf/cm}^2$ • : 2.0 cm • : 2.5 cm • TRUSS PITCH : 200 mm 					
LATTICE		6 1-D14 2-D8 30.0cm	SUPPORT		CAMBER			2-Span
TYPE	h (mm)	SLAB THK. (mm)	SUPP.	NONE	1.0cm	L/200	L/250	
A6a- 65	65	120	C 4900	D 2650	D 3100	D 3300	D 3200	-
A6a- 70	70	125	C 5000	D 2750	D 3200	D 3450	D 3300	-
A6a- 75	75	130	C 5100	D 2800	D 3300	D 3550	D 3450	-
A6a- 80	80	135	C 5200	D 2900	D 3400	D 3700	D 3550	-
A6a- 85	85	140	C 5300	D 2950	D 3500	D 3800	D 3650	-
A6a- 90	90	145	C 5400	D 3050	D 3600	D 3900	D 3750	-
A6a- 95	95	150	C 5450	D 3100	D 3650	D 4000	D 3850	-
A6a-100	100	155	C 5550	D 3150	D 3750	D 4100	D 3950	-
A6a-105	105	160	C 5600	D 3250	D 3800	D 4200	D 4050	-
A6a-110	110	165	C 5650	D 3300	D 3900	D 4300	D 4150	-
A6a-115	115	170	C 5750	D 3350	D 3950	D 4400	D 4200	-
A6a-120	120	175	C 5800	D 3400	D 4000	D 4500	D 4300	-
A6a-125	125	180	C 5850	D 3450	D 4050	D 4550	D 4350	-
A6a-130	130	185	C 5900	D 3500	D 4150	D 4650	D 4450	-
A6a-135	135	190	C 5950	D 3550	D 4200	D 4700	D 4500	-
A6a-140	140	195	C 6000	D 3600	D 4250	T 4700	D 4600	-
A6a-145	145	200	C 6000	D 3650	D 4300	T 4750	D 4650	-
A6a-150	150	205	C 6050	D 3650	D 4350	T 4800	D 4750	-
A6a-155	155	210	C 6100	D 3700	D 4400	T 4800	D 4800	-
A6a-160	160	215	C 6100	D 3750	D 4450	T 4850	D 4850	-
A6a-165	165	220	C 6150	D 3800	D 4500	L 4800	L 4800	-
A6a-170	170	225	C 6200	D 3850	D 4550	L 4550	L 4550	-
A6a-175	175	230	C 6200	D 3850	L 4300	L 4300	L 4300	-
A6a-180	180	235	C 6250	D 3900	L 4100	L 4100	L 4100	-
A6a-185	185	240	L 5900	L 3850	L 3850	L 3850	L 3850	-
A6a-190	190	245	L 5550	L 3650	L 3650	L 3650	L 3650	-
A6a-195	195	250	L 5250	L 3500	L 3500	L 3500	L 3500	-

Note - D : Deflection, C : Compression, T : Tension, L : Lattice (79p.)

철 골 조			시공시 트러스데크의 허용 스패					
A1 - TYPE			<ul style="list-style-type: none"> • $f_{ck}=210\text{kgf/cm}^2$ • $f_y=5,000\text{kgf/cm}^2$ • : 2.0 cm • : 2.5 cm • TRUSS PITCH : 200 mm 					
LATTICE		5 1-D10 2-D7 20.0cm	SUPPORT		CAMBER			2-Span
TYPE	h (mm)	SLAB THK. (mm)	SUPP.	NONE	1.0cm	L/200	L/250	
A1- 65	65	120	C 3850	D 2350	D 2750	D 2900	D 2800	C 2050
A1- 70	70	125	C 3950	D 2400	D 2850	D 3000	D 2900	C 2100
A1- 75	75	130	C 4050	D 2500	D 2950	C 3050	D 3000	C 2150
A1- 80	80	135	C 4150	D 2550	D 3000	C 3100	D 3100	C 2200
A1- 85	85	140	C 4250	D 2600	D 3100	C 3200	D 3200	C 2250
A1- 90	90	145	C 4300	D 2700	D 3150	C 3250	D 3250	C 2250
A1- 95	95	150	C 4400	D 2750	D 3250	C 3300	C 3300	C 2300
A1-100	100	155	C 4450	D 2800	D 3300	C 3350	C 3350	C 2350
A1-105	105	160	C 4550	D 2850	D 3350	C 3400	C 3400	C 2400
A1-110	110	165	C 4600	D 2900	D 3450	C 3450	C 3450	C 2400
A1-115	115	170	C 4650	D 2950	D 3500	C 3500	C 3500	C 2450
A1-120	120	175	C 4700	D 3000	C 3500	C 3500	C 3500	C 2450
A1-125	125	180	C 4750	D 3050	C 3550	C 3550	C 3550	C 2500
A1-130	130	185	C 4800	D 3050	C 3600	C 3600	C 3600	C 2500
A1-135	135	190	C 4800	D 3100	C 3600	C 3600	C 3600	C 2500
A1-140	140	195	C 4850	D 3150	L 3400	L 3400	L 3400	C 2550
A1-145	145	200	C 4900	D 3200	L 3200	L 3200	L 3200	C 2550
A1-150	150	205	L 4650	L 3050	L 3050	L 3050	L 3050	L 2450
A1-155	155	210	L 4400	L 2900	L 2900	L 2900	L 2900	L 2300
A1-160	160	215	L 4150	L 2700	L 2700	L 2700	L 2700	L 2200
A1-165	165	220	L 3900	L 2550	L 2550	L 2550	L 2550	L 2050
A1-170	170	225	L 3650	L 2450	L 2450	L 2450	L 2450	L 1950
A1-175	175	230	L 3450	L 2300	L 2300	L 2300	L 2300	L 1850
A1-180	180	235	L 3250	L 2200	L 2200	L 2200	L 2200	L 1750
A1-185	185	240	L 3050	L 2050	L 2050	L 2050	L 2050	L 1650
A1-190	190	245	L 2900	L 1950	L 1950	L 1950	L 1950	L 1550
A1-195	195	250	L 2700	L 1850	L 1850	L 1850	L 1850	L 1450

Note - D : Deflection, C : Compression, T : Tension, L : Lattice (79p.)

철 골 조			시공시 트러스데크의 허용 스펠					
A2 - TYPE			<ul style="list-style-type: none"> • $f_{ck}=210\text{ kgf/cm}^2$ • $f_y=5,000\text{ kgf/cm}^2$ • : 2.0 cm • : 2.5 cm • TRUSS PITCH : 200 mm 					
LATTICE		5 1-D12 2-D8 20.0cm	SUPPORT		CAMBER			2-Span
TYPE	h (mm)	SLAB THK. (mm)	SUPP.	NONE	1.0cm	L/200	L/250	
A2- 65	65	120	C 5000	D 2500	D 2950	D 3100	D 3000	C 2600
A2- 70	70	125	C 5150	D 2600	D 3050	D 3250	D 3100	C 2700
A2- 75	75	130	C 5250	D 2650	D 3150	D 3350	D 3250	C 2750
A2- 80	80	135	C 5400	D 2750	D 3250	D 3450	D 3350	C 2800
A2- 85	85	140	C 5500	D 2800	D 3300	D 3600	D 3450	C 2850
A2- 90	90	145	C 5600	D 2850	D 3400	D 3700	D 3550	C 2900
A2- 95	95	150	C 5700	D 2950	D 3450	D 3800	D 3650	C 2950
A2-100	100	155	C 5800	D 3000	D 3550	D 3900	D 3700	C 3000
A2-105	105	160	C 5900	D 3050	D 3600	D 3950	D 3800	C 3050
A2-110	110	165	C 6000	D 3100	D 3650	D 4050	D 3900	C 3100
A2-115	115	170	C 6050	D 3150	D 3750	D 4150	D 4000	C 3150
A2-120	120	175	C 6150	D 3200	D 3800	D 4250	D 4050	C 3200
A2-125	125	180	C 6200	D 3250	D 3850	L 4050	L 4050	C 3200
A2-130	130	185	L 5950	D 3300	L 3850	L 3850	L 3850	L 3100
A2-135	135	190	L 5600	D 3350	L 3650	L 3650	L 3650	L 2900
A2-140	140	195	L 5300	D 3400	L 3450	L 3450	L 3450	L 2750
A2-145	145	200	L 5000	L 3250	L 3250	L 3250	L 3250	L 2600
A2-150	150	205	L 4700	L 3100	L 3100	L 3100	L 3100	L 2450
A2-155	155	210	L 4450	L 2900	L 2900	L 2900	L 2900	L 2350
A2-160	160	215	L 4200	L 2750	L 2750	L 2750	L 2750	L 2200
A2-165	165	220	L 3950	L 2600	L 2600	L 2600	L 2600	L 2100
A2-170	170	225	L 3700	L 2450	L 2450	L 2450	L 2450	L 1950
A2-175	175	230	L 3500	L 2350	L 2350	L 2350	L 2350	L 1850
A2-180	180	235	L 3300	L 2200	L 2200	L 2200	L 2200	L 1750
A2-185	185	240	L 3100	L 2100	L 2100	L 2100	L 2100	L 1650
A2-190	190	245	L 2900	L 1950	L 1950	L 1950	L 1950	L 1550
A2-195	195	250	L 2750	L 1850	L 1850	L 1850	L 1850	L 1500

Note - D : Deflection, C : Compression, T : Tension, L : Lattice (79p.)

철 골 조			시공시 트러스데크의 허용 스패					
A3 - TYPE			<ul style="list-style-type: none"> • $f_{ck}=210\text{kgf/cm}^2$ • $f_y=5,000\text{kgf/cm}^2$ • : 2.0 cm • : 2.5 cm • TRUSS PITCH : 200 mm 					
LATTICE		5 1-D14 2-D10 20.0cm	SUPPORT		CAMBER			2-Span
TYPE	h (mm)	SLAB THK. (mm)	SUPP.	NONE	1.0cm	L/200	L/250	
A3- 65	65	120	D 6400	D 2700	D 3200	D 3400	D 3250	D 3300
A3- 70	70	125	D 6650	D 2800	D 3300	D 3550	D 3400	D 3450
A3- 75	75	130	D 6900	D 2850	D 3400	D 3700	D 3550	D 3550
A3- 80	80	135	D 7100	D 2950	D 3500	D 3800	D 3650	D 3650
A3- 85	85	140	D 7300	D 3050	D 3600	D 3950	D 3800	D 3750
A3- 90	90	145	D 7450	D 3100	D 3700	D 4050	D 3900	D 3850
A3- 95	95	150	D 7650	D 3200	D 3750	D 4150	D 4000	D 3950
A3-100	100	155	D 7800	D 3250	D 3850	D 4300	D 4100	D 4000
A3-105	105	160	L 7750	D 3300	D 3900	D 4400	D 4200	L 4000
A3-110	110	165	L 7400	D 3350	D 4000	D 4500	D 4300	L 3800
A3-115	115	170	L 7050	D 3450	D 4050	L 4550	D 4400	L 3650
A3-120	120	175	L 6700	D 3500	D 4150	L 4300	L 4300	L 3450
A3-125	125	180	L 6350	D 3550	L 4100	L 4100	L 4100	L 3300
A3-130	130	185	L 6000	D 3600	L 3900	L 3900	L 3900	L 3100
A3-135	135	190	L 5700	D 3650	L 3700	L 3700	L 3700	L 2950
A3-140	140	195	L 5350	L 3500	L 3500	L 3500	L 3500	L 2800
A3-145	145	200	L 5050	L 3300	L 3300	L 3300	L 3300	L 2650
A3-150	150	205	L 4800	L 3100	L 3100	L 3100	L 3100	L 2500
A3-155	155	210	L 4500	L 2950	L 2950	L 2950	L 2950	L 2350
A3-160	160	215	L 4250	L 2800	L 2800	L 2800	L 2800	L 2250
A3-165	165	220	L 4000	L 2650	L 2650	L 2650	L 2650	L 2100
A3-170	170	225	L 3750	L 2500	L 2500	L 2500	L 2500	L 2000
A3-175	175	230	L 3550	L 2350	L 2350	L 2350	L 2350	L 1900
A3-180	180	235	L 3350	L 2250	L 2250	L 2250	L 2250	L 1800
A3-185	185	240	L 3150	L 2100	L 2100	L 2100	L 2100	L 1700
A3-190	190	245	L 2950	L 2000	L 2000	L 2000	L 2000	L 1600
A3-195	195	250	L 2800	L 1900	L 1900	L 1900	L 1900	L 1500

Note - D : Deflection, C : Compression, T : Tension, L : Lattice (79p.)

철 골 조			시공시 트러스데크의 허용 스패					
A4 - TYPE			<ul style="list-style-type: none"> • $f_{ck}=210\text{ kgf/cm}^2$ • $f_y=5,000\text{ kgf/cm}^2$ • : 2.0 cm • : 2.5 cm • TRUSS PITCH : 200 mm 					
LATTICE	5							
	1-D10	2-D6						
	20.0cm							
		SLAB THK. (mm)	SUPPORT		CAMBER			2-Span
TYPE	h (mm)		SUPP.	NONE	1.0cm	L/200	L/250	
A4- 65	65	120	C 2850	D 2250	D 2650	D 2750	D 2700	C 1550
A4- 70	70	125	C 2900	D 2350	D 2750	D 2850	D 2800	C 1550
A4- 75	75	130	C 3000	D 2400	D 2850	D 3000	D 2850	C 1600
A4- 80	80	135	C 3050	D 2450	D 2900	D 3050	D 2950	C 1650
A4- 85	85	140	C 3100	D 2500	D 3000	D 3150	D 3050	C 1650
A4- 90	90	145	C 3150	D 2600	D 3050	D 3250	D 3150	C 1700
A4- 95	95	150	C 3200	D 2650	D 3100	C 3300	D 3200	C 1700
A4-100	100	155	C 3250	D 2700	D 3200	C 3350	D 3300	C 1750
A4-105	105	160	C 3300	D 2750	D 3250	C 3400	D 3350	C 1750
A4-110	110	165	C 3350	D 2800	D 3300	C 3450	D 3450	C 1800
A4-115	115	170	C 3400	D 2850	D 3350	C 3500	D 3500	C 1800
A4-120	120	175	C 3450	D 2850	D 3400	C 3550	D 3550	C 1850
A4-125	125	180	C 3450	D 2900	D 3450	C 3550	C 3550	C 1850
A4-130	130	185	C 3500	D 2950	D 3500	C 3600	C 3600	C 1850
A4-135	135	190	C 3500	D 3000	D 3550	C 3600	C 3600	C 1850
A4-140	140	195	C 3500	D 3050	L 3400	L 3400	L 3400	C 1850
A4-145	145	200	C 3550	D 3050	L 3200	L 3200	L 3200	C 1900
A4-150	150	205	C 3550	L 3050	L 3050	L 3050	L 3050	C 1900
A4-155	155	210	C 3600	L 2850	L 2850	L 2850	L 2850	C 1900
A4-160	160	215	C 3600	L 2700	L 2700	L 2700	L 2700	C 1900
A4-165	165	220	C 3600	L 2550	L 2550	L 2550	L 2550	C 1900
A4-170	170	225	C 3650	L 2450	L 2450	L 2450	L 2450	C 1950
A4-175	175	230	L 3450	L 2300	L 2300	L 2300	L 2300	L 1850
A4-180	180	235	L 3250	L 2150	L 2150	L 2150	L 2150	L 1750
A4-185	185	240	L 3050	L 2050	L 2050	L 2050	L 2050	L 1650
A4-190	190	245	L 2900	L 1950	L 1950	L 1950	L 1950	L 1550
A4-195	195	250	L 2700	L 1850	L 1850	L 1850	L 1850	L 1450

Note - D : Deflection, C : Compression, T : Tension, L : Lattice (79p.)

철 골 조			시공시 트러스데크의 허용 스패						
A5 - TYPE			<ul style="list-style-type: none"> • $f_{ck}=210\text{kgf/cm}^2$ • $f_y=5,000\text{kgf/cm}^2$ • : 2.0 cm • : 2.5 cm • TRUSS PITCH : 200 mm 						
LATTICE		5 1-D12 2-D7 20.0cm	SUPPORT			CAMBER			2-Span
TYPE	h (mm)	SLAB THK. (mm)	SUPP.	NONE	1.0cm	L/200	L/250		
A5- 65	65	120	C 3850	D 2400	D 2850	D 3000	D 2900	C 2050	
A5- 70	70	125	C 3950	D 2500	D 2950	D 3100	D 3000	C 2100	
A5- 75	75	130	C 4050	D 2550	D 3050	D 3250	D 3100	C 2150	
A5- 80	80	135	C 4150	D 2650	D 3100	D 3350	D 3200	C 2200	
A5- 85	85	140	C 4200	D 2700	D 3200	D 3450	D 3300	C 2200	
A5- 90	90	145	C 4300	D 2750	D 3300	D 3550	D 3400	C 2250	
A5- 95	95	150	C 4350	D 2850	D 3350	D 3650	D 3500	C 2300	
A5-100	100	155	C 4450	D 2900	D 3400	D 3700	D 3600	C 2350	
A5-105	105	160	C 4500	D 2950	D 3500	D 3800	D 3650	C 2350	
A5-110	110	165	C 4550	D 3000	D 3550	D 3900	D 3750	C 2400	
A5-115	115	170	C 4600	D 3050	D 3600	D 4000	D 3800	C 2400	
A5-120	120	175	C 4700	D 3100	D 3650	D 4050	D 3900	C 2450	
A5-125	125	180	C 4700	D 3150	D 3700	L 4050	D 3950	C 2450	
A5-130	130	185	C 4750	D 3200	D 3800	L 3800	L 3800	C 2500	
A5-135	135	190	C 4800	D 3250	L 3600	L 3600	L 3600	C 2500	
A5-140	140	195	C 4850	D 3250	L 3450	L 3450	L 3450	C 2550	
A5-145	145	200	C 4850	L 3250	L 3250	L 3250	L 3250	C 2550	
A5-150	150	205	L 4700	L 3050	L 3050	L 3050	L 3050	L 2450	
A5-155	155	210	L 4400	L 2900	L 2900	L 2900	L 2900	L 2300	
A5-160	160	215	L 4150	L 2750	L 2750	L 2750	L 2750	L 2200	
A5-165	165	220	L 3950	L 2600	L 2600	L 2600	L 2600	L 2100	
A5-170	170	225	L 3700	L 2450	L 2450	L 2450	L 2450	L 1950	
A5-175	175	230	L 3500	L 2300	L 2300	L 2300	L 2300	L 1850	
A5-180	180	235	L 3300	L 2200	L 2200	L 2200	L 2200	L 1750	
A5-185	185	240	L 3100	L 2100	L 2100	L 2100	L 2100	L 1650	
A5-190	190	245	L 2900	L 1950	L 1950	L 1950	L 1950	L 1550	
A5-195	195	250	L 2750	L 1850	L 1850	L 1850	L 1850	L 1500	

Note - D : Deflection, C : Compression, T : Tension, L : Lattice (79p.)

철 골 조			시공시 트러스데크의 허용 스펠					
A6 - TYPE			<ul style="list-style-type: none"> • : $f_{ck}=210\text{ kgf/cm}^2$ • : $f_y=5,000\text{ kgf/cm}^2$ • : 2.0 cm • : 2.5 cm • TRUSS PITCH : 200 mm 					
L A T T I C E	5							
	1-D14	2-D8						
		20.0cm						
		SLAB THK. (mm)	SUPPORT		CAMBER			2-Span
TYPE	h (mm)		SUPP.	NONE	1.0cm	L/200	L/250	
A6- 65	65	120	C 4950	D 2550	D 3000	D 3200	D 3100	C 2600
A6- 70	70	125	C 5100	D 2650	D 3100	D 3350	D 3200	C 2650
A6- 75	75	130	C 5250	D 2700	D 3200	D 3450	D 3350	C 2750
A6- 80	80	135	C 5350	D 2800	D 3300	D 3600	D 3450	C 2800
A6- 85	85	140	C 5450	D 2850	D 3400	D 3700	D 3550	C 2850
A6- 90	90	145	C 5600	D 2950	D 3500	D 3800	D 3650	C 2900
A6- 95	95	150	C 5700	D 3000	D 3550	D 3900	D 3750	C 2950
A6-100	100	155	C 5800	D 3050	D 3650	D 4000	D 3850	C 3000
A6-105	105	160	C 5850	D 3150	D 3700	D 4100	D 3950	C 3050
A6-110	110	165	C 5950	D 3200	D 3800	D 4200	D 4050	C 3100
A6-115	115	170	C 6050	D 3250	D 3850	D 4300	D 4100	C 3150
A6-120	120	175	C 6100	D 3300	D 3900	L 4300	D 4200	C 3150
A6-125	125	180	C 6150	D 3350	D 3950	L 4050	L 4050	C 3200
A6-130	130	185	L 5950	D 3400	L 3850	L 3850	L 3850	L 3100
A6-135	135	190	L 5650	D 3450	L 3650	L 3650	L 3650	L 2950
A6-140	140	195	L 5350	L 3450	L 3450	L 3450	L 3450	L 2800
A6-145	145	200	L 5050	L 3300	L 3300	L 3300	L 3300	L 2650
A6-150	150	205	L 4750	L 3100	L 3100	L 3100	L 3100	L 2500
A6-155	155	210	L 4450	L 2950	L 2950	L 2950	L 2950	L 2350
A6-160	160	215	L 4200	L 2750	L 2750	L 2750	L 2750	L 2200
A6-165	165	220	L 3950	L 2600	L 2600	L 2600	L 2600	L 2100
A6-170	170	225	L 3750	L 2500	L 2500	L 2500	L 2500	L 2000
A6-175	175	230	L 3550	L 2350	L 2350	L 2350	L 2350	L 1900
A6-180	180	235	L 3300	L 2200	L 2200	L 2200	L 2200	L 1750
A6-185	185	240	L 3150	L 2100	L 2100	L 2100	L 2100	L 1700
A6-190	190	245	L 2950	L 2000	L 2000	L 2000	L 2000	L 1600
A6-195	195	250	L 2750	L 1900	L 1900	L 1900	L 1900	L 1500

Note - D : Deflection, C : Compression, T : Tension, L : Lattice (79p.)

철 골 조			시공시 트러스데크의 허용 스패						
A1a - TYPE			<ul style="list-style-type: none"> • $f_{ck}=210\text{kgf/cm}^2$ • $f_y=5,000\text{kgf/cm}^2$ • : 2.0 cm • : 2.5 cm • TRUSS PITCH : 200 mm 						
LATTICE		6 1-D10 2-D7 20.0cm	SLAB THK. (mm)		SUPPORT		CAMBER		2-Span
TYPE	h (mm)		SUPP.	NONE	1.0cm	L/200	L/250		
A1a- 65	65	120	C 3850	D 2350	D 2750	D 2900	D 2800	C 2050	
A1a- 70	70	125	C 3950	D 2400	D 2850	D 3000	D 2900	C 2100	
A1a- 75	75	130	C 4050	D 2500	D 2950	C 3050	D 3000	C 2150	
A1a- 80	80	135	C 4150	D 2550	D 3000	C 3100	D 3100	C 2200	
A1a- 85	85	140	C 4250	D 2600	D 3100	C 3200	D 3200	C 2250	
A1a- 90	90	145	C 4300	D 2700	D 3150	C 3250	D 3250	C 2250	
A1a- 95	95	150	C 4400	D 2750	D 3250	C 3300	C 3300	C 2300	
A1a-100	100	155	C 4450	D 2800	D 3300	C 3350	C 3350	C 2350	
A1a-105	105	160	C 4550	D 2850	D 3350	C 3400	C 3400	C 2400	
A1a-110	110	165	C 4600	D 2900	D 3450	C 3450	C 3450	C 2400	
A1a-115	115	170	C 4650	D 2950	D 3500	C 3500	C 3500	C 2450	
A1a-120	120	175	C 4700	D 3000	C 3500	C 3500	C 3500	C 2450	
A1a-125	125	180	C 4750	D 3050	C 3550	C 3550	C 3550	C 2500	
A1a-130	130	185	C 4800	D 3050	C 3600	C 3600	C 3600	C 2500	
A1a-135	135	190	C 4800	D 3100	C 3600	C 3600	C 3600	C 2500	
A1a-140	140	195	C 4850	D 3150	C 3650	C 3650	C 3650	C 2550	
A1a-145	145	200	C 4900	D 3200	C 3650	C 3650	C 3650	C 2550	
A1a-150	150	205	C 4900	D 3200	C 3700	C 3700	C 3700	C 2550	
A1a-155	155	210	C 4950	D 3250	C 3700	C 3700	C 3700	C 2600	
A1a-160	160	215	C 4950	D 3300	C 3750	C 3750	C 3750	C 2600	
A1a-165	165	220	C 5000	D 3350	C 3750	C 3750	C 3750	C 2600	
A1a-170	170	225	C 5000	D 3350	C 3750	C 3750	C 3750	C 2600	
A1a-175	175	230	C 5050	D 3400	C 3800	C 3800	C 3800	C 2650	
A1a-180	180	235	C 5050	D 3400	C 3800	C 3800	C 3800	C 2650	
A1a-185	185	240	C 5050	D 3450	C 3800	C 3800	C 3800	C 2650	
A1a-190	190	245	C 5100	D 3500	C 3850	C 3850	C 3850	C 2650	
A1a-195	195	250	C 5100	D 3500	C 3850	C 3850	C 3850	C 2650	

Note - D : Deflection, C : Compression, T : Tension, L : Lattice (79p.)

철 골 조			시공시 트러스데크의 허용 스펠					
A2a - TYPE			<ul style="list-style-type: none"> • $f_{ck}=210\text{ kgf/cm}^2$ • $f_y=5,000\text{ kgf/cm}^2$ • : 2.0 cm • : 2.5 cm • TRUSS PITCH : 200 mm 					
LATTICE		6 1-D12 2-D8 20.0cm	SUPPORT		CAMBER			2-Span
TYPE	h (mm)	SLAB THK. (mm)	SUPP.	NONE	1.0cm	L/200	L/250	
A2a- 65	65	120	C 5000	D 2500	D 2950	D 3100	D 3000	C 2600
A2a- 70	70	125	C 5150	D 2600	D 3050	D 3250	D 3100	C 2700
A2a- 75	75	130	C 5250	D 2650	D 3150	D 3350	D 3250	C 2750
A2a- 80	80	135	C 5400	D 2750	D 3250	D 3450	D 3350	C 2800
A2a- 85	85	140	C 5500	D 2800	D 3300	D 3600	D 3450	C 2850
A2a- 90	90	145	C 5600	D 2850	D 3400	D 3700	D 3550	C 2900
A2a- 95	95	150	C 5700	D 2950	D 3450	D 3800	D 3650	C 2950
A2a-100	100	155	C 5800	D 3000	D 3550	D 3900	D 3700	C 3000
A2a-105	105	160	C 5900	D 3050	D 3600	D 3950	D 3800	C 3050
A2a-110	110	165	C 6000	D 3100	D 3650	D 4050	D 3900	C 3100
A2a-115	115	170	C 6050	D 3150	D 3750	D 4150	D 4000	C 3150
A2a-120	120	175	C 6150	D 3200	D 3800	D 4250	D 4050	C 3200
A2a-125	125	180	C 6200	D 3250	D 3850	D 4300	D 4150	C 3200
A2a-130	130	185	C 6250	D 3300	D 3900	D 4400	D 4200	C 3250
A2a-135	135	190	C 6300	D 3350	D 3950	D 4450	D 4250	C 3250
A2a-140	140	195	C 6350	D 3400	D 4000	D 4550	D 4350	C 3300
A2a-145	145	200	C 6400	D 3450	D 4050	D 4600	D 4400	C 3300
A2a-150	150	205	C 6450	D 3450	D 4100	D 4700	D 4450	C 3350
A2a-155	155	210	C 6450	D 3500	D 4150	D 4750	D 4550	C 3350
A2a-160	160	215	C 6500	D 3550	D 4200	D 4800	D 4600	C 3350
A2a-165	165	220	C 6550	D 3600	D 4250	D 4850	D 4650	C 3400
A2a-170	170	225	C 6600	D 3600	D 4300	D 4950	D 4700	C 3400
A2a-175	175	230	C 6600	D 3650	D 4350	L 4850	D 4750	C 3400
A2a-180	180	235	C 6650	D 3700	D 4400	L 4600	L 4600	C 3450
A2a-185	185	240	C 6700	D 3700	L 4350	L 4350	L 4350	C 3450
A2a-190	190	245	L 6350	D 3750	L 4100	L 4100	L 4100	L 3300
A2a-195	195	250	L 6000	D 3800	L 3900	L 3900	L 3900	L 3100

Note - D : Deflection, C : Compression, T : Tension, L : Lattice (79p.)

철 골 조			시공시 트러스데크의 허용 스패					
A3a - TYPE			<ul style="list-style-type: none"> • $f_{ck}=210\text{ kgf/cm}^2$ • $f_y=5,000\text{ kgf/cm}^2$ • : 2.0 cm • : 2.5 cm • TRUSS PITCH : 200 mm 					
LATTICE		6 1-D14 2-D10 20.0cm	SUPPORT		CAMBER			2-Span
TYPE	h (mm)	SLAB THK. (mm)	SUPP.	NONE	1.0cm	L/200	L/250	
A3a- 65	65	120	D 6400	D 2700	D 3200	D 3400	D 3250	D 3300
A3a- 70	70	125	D 6650	D 2800	D 3300	D 3550	D 3400	D 3450
A3a- 75	75	130	D 6900	D 2850	D 3400	D 3700	D 3550	D 3550
A3a- 80	80	135	D 7100	D 2950	D 3500	D 3800	D 3650	D 3650
A3a- 85	85	140	D 7300	D 3050	D 3600	D 3950	D 3800	D 3750
A3a- 90	90	145	D 7450	D 3100	D 3700	D 4050	D 3900	D 3850
A3a- 95	95	150	D 7650	D 3200	D 3750	D 4150	D 4000	D 3950
A3a-100	100	155	D 7800	D 3250	D 3850	D 4300	D 4100	D 4000
A3a-105	105	160	D 7950	D 3300	D 3900	D 4400	D 4200	D 4100
A3a-110	110	165	D 7950	D 3350	D 4000	D 4500	D 4300	D 4200
A3a-115	115	170	D 7950	D 3450	D 4050	D 4600	D 4400	D 4250
A3a-120	120	175	D 7950	D 3500	D 4150	D 4700	D 4500	D 4350
A3a-125	125	180	D 7950	D 3550	D 4200	D 4800	D 4550	D 4400
A3a-130	130	185	D 7950	D 3600	D 4250	D 4850	D 4650	D 4450
A3a-135	135	190	D 7950	D 3650	D 4300	D 4950	D 4750	D 4550
A3a-140	140	195	D 7950	D 3700	D 4400	D 5050	D 4800	D 4600
A3a-145	145	200	D 7950	D 3750	D 4450	D 5100	D 4900	D 4650
A3a-150	150	205	D 7950	D 3800	D 4500	D 5200	D 4950	D 4700
A3a-155	155	210	D 7950	D 3850	D 4550	D 5300	D 5050	D 4750
A3a-160	160	215	D 7950	D 3850	D 4600	D 5350	D 5100	L 4650
A3a-165	165	220	D 7950	D 3900	D 4650	D 5450	D 5150	L 4400
A3a-170	170	225	D 7950	D 3950	D 4700	L 5200	L 5200	L 4150
A3a-175	175	230	L 7600	D 4000	D 4750	L 4900	L 4900	L 3900
A3a-180	180	235	L 7200	D 4050	L 4650	L 4650	L 4650	L 3700
A3a-185	185	240	L 6800	D 4050	L 4400	L 4400	L 4400	L 3500
A3a-190	190	245	L 6450	D 4100	L 4150	L 4150	L 4150	L 3350
A3a-195	195	250	L 6100	L 3950	L 3950	L 3950	L 3950	L 3150

Note - D : Deflection, C : Compression, T : Tension, L : Lattice (79p.)

철 골 조			시공시 트러스데크의 허용 스펠					
A4a - TYPE			<ul style="list-style-type: none"> • : $f_{ck}=210\text{ kgf/cm}^2$ • : $f_y=5,000\text{ kgf/cm}^2$ • : 2.0 cm • : 2.5 cm • TRUSS PITCH : 200 mm 					
LATTICE	6							
	1-D10	2-D6						
	20.0cm							
		SLAB THK. (mm)	SUPPORT		CAMBER			2-Span
TYPE	h (mm)		SUPP.	NONE	1.0cm	L/200	L/250	
A4a- 65	65	120	C 2850	D 2250	D 2650	D 2750	D 2700	C 1550
A4a- 70	70	125	C 2900	D 2350	D 2750	D 2850	D 2800	C 1550
A4a- 75	75	130	C 3000	D 2400	D 2850	D 3000	D 2850	C 1600
A4a- 80	80	135	C 3050	D 2450	D 2900	D 3050	D 2950	C 1650
A4a- 85	85	140	C 3100	D 2500	D 3000	D 3150	D 3050	C 1650
A4a- 90	90	145	C 3150	D 2600	D 3050	D 3250	D 3150	C 1700
A4a- 95	95	150	C 3200	D 2650	D 3100	C 3300	D 3200	C 1700
A4a-100	100	155	C 3250	D 2700	D 3200	C 3350	D 3300	C 1750
A4a-105	105	160	C 3300	D 2750	D 3250	C 3400	D 3350	C 1750
A4a-110	110	165	C 3350	D 2800	D 3300	C 3450	D 3450	C 1800
A4a-115	115	170	C 3400	D 2850	D 3350	C 3500	D 3500	C 1800
A4a-120	120	175	C 3450	D 2850	D 3400	C 3550	D 3550	C 1850
A4a-125	125	180	C 3450	D 2900	D 3450	C 3550	C 3550	C 1850
A4a-130	130	185	C 3500	D 2950	D 3500	C 3600	C 3600	C 1850
A4a-135	135	190	C 3500	D 3000	D 3550	C 3600	C 3600	C 1850
A4a-140	140	195	C 3500	D 3050	D 3600	C 3650	C 3650	C 1850
A4a-145	145	200	C 3550	D 3050	D 3650	C 3650	C 3650	C 1900
A4a-150	150	205	C 3550	D 3100	D 3700	C 3700	C 3700	C 1900
A4a-155	155	210	C 3600	D 3150	D 3700	C 3700	C 3700	C 1900
A4a-160	160	215	C 3600	D 3150	D 3750	C 3750	C 3750	C 1900
A4a-165	165	220	C 3600	D 3200	C 3750	C 3750	C 3750	C 1900
A4a-170	170	225	C 3650	D 3250	C 3750	C 3750	C 3750	C 1950
A4a-175	175	230	C 3650	D 3250	C 3800	C 3800	C 3800	C 1950
A4a-180	180	235	C 3650	D 3300	C 3800	C 3800	C 3800	C 1950
A4a-185	185	240	C 3650	D 3300	C 3800	C 3800	C 3800	C 1950
A4a-190	190	245	C 3700	D 3350	C 3850	C 3850	C 3850	C 1950
A4a-195	195	250	C 3700	D 3350	C 3850	C 3850	C 3850	C 1950

Note - D : Deflection, C : Compression, T : Tension, L : Lattice (79p.)

철 골 조			시공시 트러스데크의 허용 스패						
A5a - TYPE			<ul style="list-style-type: none"> • $f_{ck}=210\text{ kgf/cm}^2$ • $f_y=5,000\text{ kgf/cm}^2$ • : 2.0 cm • : 2.5 cm • TRUSS PITCH : 200 mm 						
LATTICE		6 1-D12 2-D7 20.0cm	SLAB THK. (mm)		SUPPORT		CAMBER		2-Span
TYPE	h (mm)		SUPP.	NONE	1.0cm	L/200	L/250		
A5a- 65	65	120	C 3850	D 2400	D 2850	D 3000	D 2900	C 2050	
A5a- 70	70	125	C 3950	D 2500	D 2950	D 3100	D 3000	C 2100	
A5a- 75	75	130	C 4050	D 2550	D 3050	D 3250	D 3100	C 2150	
A5a- 80	80	135	C 4150	D 2650	D 3100	D 3350	D 3200	C 2200	
A5a- 85	85	140	C 4200	D 2700	D 3200	D 3450	D 3300	C 2200	
A5a- 90	90	145	C 4300	D 2750	D 3300	D 3550	D 3400	C 2250	
A5a- 95	95	150	C 4350	D 2850	D 3350	D 3650	D 3500	C 2300	
A5a-100	100	155	C 4450	D 2900	D 3400	D 3700	D 3600	C 2350	
A5a-105	105	160	C 4500	D 2950	D 3500	D 3800	D 3650	C 2350	
A5a-110	110	165	C 4550	D 3000	D 3550	D 3900	D 3750	C 2400	
A5a-115	115	170	C 4600	D 3050	D 3600	D 4000	D 3800	C 2400	
A5a-120	120	175	C 4700	D 3100	D 3650	D 4050	D 3900	C 2450	
A5a-125	125	180	C 4700	D 3150	D 3700	D 4150	D 3950	C 2450	
A5a-130	130	185	C 4750	D 3200	D 3800	D 4200	D 4050	C 2500	
A5a-135	135	190	C 4800	D 3250	D 3850	D 4300	D 4100	C 2500	
A5a-140	140	195	C 4850	D 3250	D 3900	D 4350	D 4150	C 2550	
A5a-145	145	200	C 4850	D 3300	D 3950	D 4400	D 4250	C 2550	
A5a-150	150	205	C 4900	D 3350	D 4000	T 4400	D 4300	C 2550	
A5a-155	155	210	C 4900	D 3400	D 4000	T 4450	D 4350	C 2550	
A5a-160	160	215	C 4950	D 3400	D 4050	T 4450	D 4400	C 2600	
A5a-165	165	220	C 4950	D 3450	D 4100	T 4500	D 4450	C 2600	
A5a-170	170	225	C 5000	D 3500	D 4150	T 4500	D 4500	C 2600	
A5a-175	175	230	C 5000	D 3500	D 4200	T 4550	D 4550	C 2600	
A5a-180	180	235	C 5050	D 3550	D 4250	T 4550	T 4550	C 2650	
A5a-185	185	240	C 5050	D 3600	D 4250	L 4300	L 4300	C 2650	
A5a-190	190	245	C 5100	D 3600	L 4100	L 4100	L 4100	C 2650	
A5a-195	195	250	C 5100	D 3650	L 3900	L 3900	L 3900	C 2650	

Note - D : Deflection, C : Compression, T : Tension, L : Lattice (79p.)

철 골 조			시공시 트러스데크의 허용 스패					
A6a - TYPE			<ul style="list-style-type: none"> • : $f_{ck}=210\text{ kgf/cm}^2$ • : $f_y=5,000\text{ kgf/cm}^2$ • : 2.0 cm • : 2.5 cm • TRUSS PITCH : 200 mm 					
LATTICE	6							
	1-D14	2-D8						
	20.0cm							
		SLAB THK. (mm)	SUPPORT		CAMBER			2-Span
TYPE	h (mm)		SUPP.	NONE	1.0cm	L/200	L/250	
A6a- 65	65	120	C 4950	D 2550	D 3000	D 3200	D 3100	C 2600
A6a- 70	70	125	C 5100	D 2650	D 3100	D 3350	D 3200	C 2650
A6a- 75	75	130	C 5250	D 2700	D 3200	D 3450	D 3350	C 2750
A6a- 80	80	135	C 5350	D 2800	D 3300	D 3600	D 3450	C 2800
A6a- 85	85	140	C 5450	D 2850	D 3400	D 3700	D 3550	C 2850
A6a- 90	90	145	C 5600	D 2950	D 3500	D 3800	D 3650	C 2900
A6a- 95	95	150	C 5700	D 3000	D 3550	D 3900	D 3750	C 2950
A6a-100	100	155	C 5800	D 3050	D 3650	D 4000	D 3850	C 3000
A6a-105	105	160	C 5850	D 3150	D 3700	D 4100	D 3950	C 3050
A6a-110	110	165	C 5950	D 3200	D 3800	D 4200	D 4050	C 3100
A6a-115	115	170	C 6050	D 3250	D 3850	D 4300	D 4100	C 3150
A6a-120	120	175	C 6100	D 3300	D 3900	D 4400	D 4200	C 3150
A6a-125	125	180	C 6150	D 3350	D 3950	D 4450	D 4250	C 3200
A6a-130	130	185	C 6200	D 3400	D 4050	D 4550	D 4350	C 3200
A6a-135	135	190	C 6250	D 3450	D 4100	D 4600	D 4400	C 3250
A6a-140	140	195	C 6300	D 3500	D 4150	D 4700	D 4500	C 3250
A6a-145	145	200	C 6350	D 3550	D 4200	D 4800	D 4550	C 3300
A6a-150	150	205	C 6400	D 3550	D 4250	D 4850	D 4650	C 3300
A6a-155	155	210	C 6450	D 3600	D 4300	D 4900	D 4700	C 3350
A6a-160	160	215	C 6500	D 3650	D 4350	D 5000	D 4750	C 3350
A6a-165	165	220	C 6550	D 3700	D 4400	D 5050	D 4850	C 3400
A6a-170	170	225	C 6550	D 3750	D 4450	D 5100	D 4900	C 3400
A6a-175	175	230	C 6600	D 3750	D 4500	L 4850	L 4850	C 3400
A6a-180	180	235	C 6650	D 3800	D 4500	L 4600	L 4600	C 3450
A6a-185	185	240	C 6650	D 3850	L 4350	L 4350	L 4350	C 3450
A6a-190	190	245	L 6400	D 3850	L 4150	L 4150	L 4150	L 3300
A6a-195	195	250	L 6050	D 3900	L 3950	L 3950	L 3950	L 3150

Note - D : Deflection, C : Compression, T : Tension, L : Lattice (79p.)

바. 사용시 트러스데크의 허용스팬

철근콘크리트조			사용시 트러스데크의 허용스팬							
A1 - TYPE			<ul style="list-style-type: none"> • $f_{ck} = 210 \text{ kgf/cm}^2$ • $f_y = 5,000 \text{ kgf/cm}^2$ • : 2.0 cm • : 2.5 cm • TRUSS PITCH : 200 mm • 가 : 100 kgf/m^2 							
L A T T I C E		5,6								
		1-D10								
		2-D7								
S P A N		30.0cm								
		1								
		SLAB THK. (mm)	LIVE LOAD (kgf/m ²)							
TYPE	h (mm)		0.00	300	500	800	1000	1250	1500	2000
A1- 65	65	120	S 4600	C 3650	C 3250	C 2800	C 2600	C 2450	C 2300	C 2050
A1- 70	70	125	S 4750	C 3750	C 3300	C 2900	C 2700	C 2500	C 2350	C 2100
A1- 75	75	130	S 4850	C 3800	C 3350	C 2950	C 2750	C 2550	C 2400	C 2150
A1- 80	80	135	S 4950	C 3850	C 3400	C 3000	C 2800	C 2600	C 2450	C 2200
A1- 85	85	140	S 5100	C 3900	C 3500	C 3050	C 2850	C 2650	C 2500	C 2250
A1- 90	90	145	C 5200	C 4000	C 3550	C 3100	C 2900	C 2700	C 2500	C 2300
A1- 95	95	150	C 5250	C 4050	C 3600	C 3150	C 2950	C 2750	C 2550	C 2300
A1-100	100	155	C 5300	C 4100	C 3650	C 3200	C 3000	C 2750	C 2600	C 2350
A1-105	105	160	C 5350	C 4150	C 3700	C 3250	C 3050	C 2800	C 2650	C 2400
A1-110	110	165	C 5400	C 4200	C 3750	C 3300	C 3050	C 2850	C 2700	C 2450
A1-115	115	170	C 5450	C 4250	C 3800	C 3350	C 3100	C 2900	C 2750	C 2450
A1-120	120	175	C 5450	C 4300	C 3850	C 3400	C 3150	C 2950	C 2750	C 2500
A1-125	125	180	C 5500	C 4350	C 3900	C 3400	C 3200	C 3000	C 2800	C 2550
A1-130	130	185	C 5550	C 4350	C 3900	C 3450	C 3250	C 3000	C 2850	C 2550
A1-135	135	190	C 5550	C 4400	C 3950	C 3500	C 3250	C 3050	C 2850	C 2600
A1-140	140	195	C 5600	C 4450	C 4000	C 3550	C 3300	C 3100	C 2900	C 2650
A1-145	145	200	C 5650	C 4500	C 4050	C 3600	C 3350	C 3100	C 2950	C 2650
A1-150	150	205	C 5650	C 4500	C 4100	C 3600	C 3400	C 3150	C 2950	C 2700
A1-155	155	210	C 5700	C 4550	C 4100	C 3650	C 3400	C 3200	C 3000	C 2700
A1-160	160	215	C 5700	C 4600	C 4150	C 3700	C 3450	C 3200	C 3050	C 2750
A1-165	165	220	C 5750	C 4650	C 4200	C 3700	C 3500	C 3250	C 3050	C 2800
A1-170	170	225	C 5750	C 4650	C 4200	C 3750	C 3500	C 3300	C 3100	C 2800
A1-175	175	230	C 5750	C 4700	C 4250	C 3800	C 3550	C 3300	C 3150	C 2850
A1-180	180	235	C 5800	C 4700	C 4300	C 3800	C 3600	C 3350	C 3150	C 2850
A1-185	185	240	C 5800	C 4750	C 4300	C 3850	C 3600	C 3350	C 3200	C 2900
A1-190	190	245	C 5850	C 4800	C 4350	C 3850	C 3650	C 3400	C 3200	C 2900
A1-195	195	250	C 5850	C 4800	C 4350	C 3900	C 3650	C 3450	C 3250	C 2950

Note - E : End Bar, C : Center Bar, L : S : (79p.)

철근콘크리트조			사용시 트러스데크의 허용 스펠							
A1 - TYPE			<ul style="list-style-type: none"> • : $f_{ck}=210\text{ kgf/cm}^2$ • : $f_y=5,000\text{ kgf/cm}^2$ • : 2.0 cm • : 2.5 cm • TRUSS PITCH : 200 mm • 가 : 100 kgf/m^2 							
L A T T I C E		5,6 1-D10 2-D7 30.0cm								
S P A N		2								
		SLAB THK. (mm)	LIVE LOAD (kgf/m ²)							
TYPE	h (mm)		0.00	300	500	800	1000	1250	1500	2000
A1- 65	65	120	E 5050	E 3750	E 3300	E 2900	E 2700	E 2500	E 2350	E 2100
A1- 70	70	125	E 5150	E 3850	E 3400	E 2950	E 2750	E 2550	E 2400	E 2150
A1- 75	75	130	E 5200	E 3900	E 3450	E 3000	E 2800	E 2600	E 2450	E 2200
A1- 80	80	135	E 5300	E 4000	E 3550	E 3100	E 2900	E 2650	E 2500	E 2250
A1- 85	85	140	E 5350	E 4050	E 3600	E 3150	E 2950	E 2700	E 2550	E 2300
A1- 90	90	145	E 5400	E 4100	E 3650	E 3200	E 3000	E 2800	E 2600	E 2350
A1- 95	95	150	E 5450	E 4200	E 3700	E 3250	E 3050	E 2850	E 2650	E 2400
A1-100	100	155	E 5500	E 4250	E 3800	E 3300	E 3100	E 2900	E 2700	E 2450
A1-105	105	160	E 5550	E 4300	E 3850	E 3350	E 3150	E 2900	E 2750	E 2500
A1-110	110	165	E 5600	E 4350	E 3900	E 3400	E 3200	E 2950	E 2800	E 2500
A1-115	115	170	E 5650	E 4400	E 3950	E 3450	E 3250	E 3000	E 2850	E 2550
A1-120	120	175	E 5700	E 4450	E 4000	E 3500	E 3300	E 3050	E 2850	E 2600
A1-125	125	180	E 5750	E 4500	E 4050	E 3550	E 3350	E 3100	E 2900	E 2650
A1-130	130	185	E 5800	E 4550	E 4100	E 3600	E 3350	E 3150	E 2950	E 2650
A1-135	135	190	E 5800	E 4600	E 4150	E 3650	E 3400	E 3200	E 3000	E 2700
A1-140	140	195	E 5850	E 4650	E 4200	E 3700	E 3450	E 3200	E 3050	E 2750
A1-145	145	200	E 5900	E 4700	E 4200	E 3750	E 3500	E 3250	E 3050	E 2800
A1-150	150	205	E 5900	E 4750	E 4250	E 3800	E 3550	E 3300	E 3100	E 2800
A1-155	155	210	E 5950	E 4750	E 4300	E 3800	E 3550	E 3350	E 3150	E 2850
A1-160	160	215	E 6000	E 4800	E 4350	E 3850	E 3600	E 3350	E 3150	E 2850
A1-165	165	220	E 6000	E 4850	E 4400	E 3900	E 3650	E 3400	E 3200	E 2900
A1-170	170	225	E 6050	E 4900	E 4400	E 3950	E 3700	E 3450	E 3250	E 2950
A1-175	175	230	E 6050	E 4900	E 4450	E 3950	E 3700	E 3450	E 3250	E 2950
A1-180	180	235	E 6100	E 4950	E 4500	E 4000	E 3750	E 3500	E 3300	E 3000
A1-185	185	240	E 6100	E 5000	E 4550	E 4050	E 3800	E 3550	E 3350	E 3050
A1-190	190	245	E 6150	E 5000	E 4550	E 4050	E 3800	E 3550	E 3350	E 3050
A1-195	195	250	E 6150	E 5050	E 4600	E 4100	E 3850	E 3600	E 3400	E 3100

Note - E : End Bar, C : Center Bar, L : S : (79p.)

철근콘크리트조			사용시 트러스테크의 허용 스펠							
A2 - TYPE			<ul style="list-style-type: none"> • : $f_{ck}=210\text{ kgf/cm}^2$ • : $f_y=5,000\text{ kgf/cm}^2$ • : 2.0 cm • : 2.5 cm • TRUSS PITCH : 200 mm • 가 : 100 kgf/m^2 							
L A T T I C E		5,6								
		1-D12								
		2-D8								
S P A N		30.0cm								
		1								
		SLAB THK. (mm)	LIVE LOAD (kgf/m ²)							
TYPE	h (mm)		0.00	300	500	800	1000	1250	1500	2000
A2- 65	65	120	S 4700	S 3750	S 3450	S 3100	C 2900	C 2700	C 2550	C 2300
A2- 70	70	125	S 4800	S 3900	S 3550	C 3200	C 3000	C 2750	C 2600	C 2350
A2- 75	75	130	S 4900	S 4000	S 3650	C 3300	C 3050	C 2850	C 2650	C 2400
A2- 80	80	135	S 5050	S 4100	S 3750	C 3350	C 3100	C 2900	C 2700	C 2450
A2- 85	85	140	S 5150	S 4200	C 3900	C 3400	C 3150	C 2950	C 2750	C 2500
A2- 90	90	145	S 5250	S 4300	C 3950	C 3450	C 3250	C 3000	C 2800	C 2550
A2- 95	95	150	S 5350	S 4400	C 4000	C 3500	C 3300	C 3050	C 2850	C 2600
A2-100	100	155	S 5450	S 4500	C 4100	C 3600	C 3350	C 3100	C 2900	C 2600
A2-105	105	160	S 5600	C 4650	C 4150	C 3650	C 3400	C 3150	C 2950	C 2650
A2-110	110	165	S 5700	C 4700	C 4200	C 3700	C 3450	C 3200	C 3000	C 2700
A2-115	115	170	S 5800	C 4750	C 4250	C 3750	C 3500	C 3250	C 3050	C 2750
A2-120	120	175	S 5900	C 4800	C 4300	C 3800	C 3550	C 3300	C 3100	C 2800
A2-125	125	180	S 6000	C 4850	C 4350	C 3850	C 3600	C 3350	C 3150	C 2850
A2-130	130	185	S 6100	C 4900	C 4400	C 3900	C 3650	C 3400	C 3200	C 2850
A2-135	135	190	S 6200	C 4950	C 4450	C 3950	C 3650	C 3400	C 3200	C 2900
A2-140	140	195	S 6250	C 5000	C 4500	C 3950	C 3700	C 3450	C 3250	C 2950
A2-145	145	200	C 6350	C 5050	C 4550	C 4000	C 3750	C 3500	C 3300	C 3000
A2-150	150	205	C 6400	C 5100	C 4600	C 4050	C 3800	C 3550	C 3350	C 3000
A2-155	155	210	C 6400	C 5150	C 4650	C 4100	C 3850	C 3600	C 3350	C 3050
A2-160	160	215	C 6450	C 5200	C 4650	C 4150	C 3900	C 3600	C 3400	C 3100
A2-165	165	220	C 6450	C 5200	C 4700	C 4200	C 3900	C 3650	C 3450	C 3100
A2-170	170	225	C 6500	C 5250	C 4750	C 4200	C 3950	C 3700	C 3450	C 3150
A2-175	175	230	C 6500	C 5300	C 4800	C 4250	C 4000	C 3700	C 3500	C 3200
A2-180	180	235	C 6550	C 5300	C 4800	C 4300	C 4000	C 3750	C 3550	C 3200
A2-185	185	240	C 6550	C 5350	C 4850	C 4350	C 4050	C 3800	C 3550	C 3250
A2-190	190	245	C 6600	C 5400	C 4900	C 4350	C 4100	C 3800	C 3600	C 3250
A2-195	195	250	C 6600	C 5400	C 4950	C 4400	C 4150	C 3850	C 3650	C 3300

Note - E : End Bar, C : Center Bar, L : (79p.)

철근콘크리트조			사용시 트러스데크의 허용 스펠							
A2 - TYPE			<ul style="list-style-type: none"> • : $f_{ck}=210\text{ kgf/cm}^2$ • : $f_y=5,000\text{ kgf/cm}^2$ • : 2.0 cm • : 2.5 cm • TRUSS PITCH : 200 mm • 가 : 100 kgf/m^2 							
L A T T I C E		5,6 1-D12 2-D8 30.0cm								
S P A N		2								
		SLAB THK. (mm)	LIVE LOAD (kgf/m ²)							
TYPE	h (mm)		0.00	300	500	800	1000	1250	1500	2000
A2- 65	65	120	E 5900	E 4350	E 3850	E 3350	E 3100	E 2850	E 2700	E 2400
A2- 70	70	125	E 6000	E 4450	E 3950	E 3400	E 3200	E 2950	E 2750	E 2500
A2- 75	75	130	E 6100	E 4550	E 4000	E 3500	E 3250	E 3000	E 2850	E 2550
A2- 80	80	135	E 6150	E 4650	E 4100	E 3600	E 3350	E 3100	E 2900	E 2600
A2- 85	85	140	E 6250	E 4750	E 4200	E 3650	E 3400	E 3150	E 2950	E 2650
A2- 90	90	145	E 6350	E 4800	E 4250	E 3750	E 3450	E 3200	E 3000	E 2700
A2- 95	95	150	E 6400	E 4900	E 4350	E 3800	E 3550	E 3300	E 3100	E 2750
A2-100	100	155	E 6450	E 4950	E 4400	E 3850	E 3600	E 3350	E 3150	E 2800
A2-105	105	160	E 6550	E 5050	E 4500	E 3950	E 3650	E 3400	E 3200	E 2850
A2-110	110	165	E 6600	E 5100	E 4550	E 4000	E 3700	E 3450	E 3250	E 2900
A2-115	115	170	E 6650	E 5150	E 4600	E 4050	E 3800	E 3500	E 3300	E 2950
A2-120	120	175	E 6700	E 5250	E 4650	E 4100	E 3850	E 3550	E 3350	E 3000
A2-125	125	180	E 6750	E 5300	E 4750	E 4150	E 3900	E 3600	E 3400	E 3050
A2-130	130	185	E 6800	E 5350	E 4800	E 4200	E 3950	E 3650	E 3450	E 3100
A2-135	135	190	E 6850	E 5400	E 4850	E 4250	E 4000	E 3700	E 3500	E 3150
A2-140	140	195	E 6900	E 5450	E 4900	E 4300	E 4050	E 3750	E 3550	E 3200
A2-145	145	200	E 6950	E 5500	E 4950	E 4400	E 4100	E 3800	E 3600	E 3250
A2-150	150	205	E 6950	E 5550	E 5000	E 4400	E 4150	E 3850	E 3650	E 3300
A2-155	155	210	E 7000	E 5600	E 5050	E 4450	E 4200	E 3900	E 3650	E 3300
A2-160	160	215	E 7050	E 5650	E 5100	E 4500	E 4250	E 3950	E 3700	E 3350
A2-165	165	220	E 7100	E 5700	E 5150	E 4550	E 4300	E 4000	E 3750	E 3400
A2-170	170	225	E 7100	E 5750	E 5200	E 4600	E 4300	E 4050	E 3800	E 3450
A2-175	175	230	E 7150	E 5800	E 5250	E 4650	E 4350	E 4050	E 3850	E 3450
A2-180	180	235	E 7200	E 5850	E 5300	E 4700	E 4400	E 4100	E 3850	E 3500
A2-185	185	240	E 7200	E 5900	E 5300	E 4750	E 4450	E 4150	E 3900	E 3550
A2-190	190	245	E 7250	E 5900	E 5350	E 4800	E 4500	E 4200	E 3950	E 3550
A2-195	195	250	E 7250	E 5950	E 5400	E 4800	E 4500	E 4200	E 4000	E 3600

Note - E : End Bar, C : Center Bar, L : S : (79p.)

철근콘크리트조			사용시 트러스테크의 허용 스패							
A3 - TYPE			<ul style="list-style-type: none"> • : $f_{ck}=210\text{ kgf/cm}^2$ • : $f_y=5,000\text{ kgf/cm}^2$ • : 2.0 cm • : 2.5 cm • TRUSS PITCH : 200 mm • 가 : 100 kgf/m^2 							
L A T T I C E		5,6								
		1-D14								
		2-D10								
S P A N		30.0cm								
		1								
			LIVE LOAD (kgf/m ²)							
TYPE	h (mm)	SLAB THK. (mm)	0.00	300	500	800	1000	1250	1500	2000
A3- 65	65	120	S 4800	S 3850	S 3550	L 3200	L 3050	L 2850	L 2700	L 2500
A3- 70	70	125	S 4950	S 3950	S 3650	S 3300	S 3100	L 2950	L 2800	L 2600
A3- 75	75	130	S 5050	S 4050	S 3750	S 3400	S 3200	L 3050	L 2900	L 2650
A3- 80	80	135	S 5150	S 4200	S 3850	S 3500	S 3300	L 3150	L 3000	L 2750
A3- 85	85	140	S 5300	S 4300	S 3950	S 3600	S 3400	L 3250	L 3100	L 2850
A3- 90	90	145	S 5400	S 4400	S 4050	S 3700	S 3500	S 3300	L 3150	L 2900
A3- 95	95	150	S 5500	S 4500	S 4150	S 3800	S 3600	S 3400	L 3250	L 3000
A3-100	100	155	S 5600	S 4600	S 4250	S 3900	S 3700	L 3500	L 3350	L 3050
A3-105	105	160	S 5700	S 4700	S 4350	S 4000	S 3800	L 3600	S 3400	L 3150
A3-110	110	165	S 5800	S 4800	S 4450	S 4050	S 3850	S 3650	L 3500	C 3250
A3-115	115	170	S 5900	S 4900	S 4550	S 4150	S 3950	S 3750	L 3600	C 3300
A3-120	120	175	S 6000	S 5000	S 4650	S 4250	S 4050	S 3850	S 3650	C 3350
A3-125	125	180	S 6100	S 5100	S 4750	S 4350	S 4150	S 3900	C 3750	C 3400
A3-130	130	185	S 6200	S 5200	S 4850	S 4450	S 4250	S 4000	C 3850	C 3450
A3-135	135	190	S 6300	S 5300	S 4950	S 4500	S 4300	S 4100	C 3900	C 3500
A3-140	140	195	S 6400	S 5400	S 5050	S 4600	S 4400	S 4150	C 3950	C 3550
A3-145	145	200	S 6500	S 5500	S 5100	S 4700	S 4500	C 4250	C 4000	C 3600
A3-150	150	205	S 6600	S 5600	S 5200	S 4800	S 4550	C 4300	C 4050	C 3650
A3-155	155	210	S 6700	S 5700	S 5300	S 4850	C 4650	C 4350	C 4050	C 3700
A3-160	160	215	S 6800	S 5750	S 5400	S 4950	C 4700	C 4400	C 4100	C 3700
A3-165	165	220	S 6850	S 5850	S 5450	C 5050	C 4750	C 4450	C 4150	C 3750
A3-170	170	225	S 6950	S 5950	S 5550	C 5100	C 4800	C 4450	C 4200	C 3800
A3-175	175	230	S 7050	S 6050	S 5650	C 5150	C 4850	C 4500	C 4250	C 3850
A3-180	180	235	S 7150	S 6150	S 5750	C 5200	C 4900	C 4550	C 4300	C 3900
A3-185	185	240	S 7250	S 6200	S 5800	C 5250	C 4950	C 4600	C 4350	C 3900
A3-190	190	245	S 7300	S 6300	S 5900	C 5300	C 5000	C 4650	C 4400	C 3950
A3-195	195	250	S 7400	S 6400	C 6000	C 5350	C 5000	C 4700	C 4400	C 4000

Note - E : End Bar, C : Center Bar, L : (79p.)

철근콘크리트조			사용시 트러스데크의 허용 스펠							
A3 - TYPE			<ul style="list-style-type: none"> • : $f_{ck}=210\text{ kgf/cm}^2$ • : $f_y=5,000\text{ kgf/cm}^2$ • : 2.0 cm • : 2.5 cm • TRUSS PITCH : 200 mm • 가 : 100 kgf/m^2 							
L A T T I C E		5,6								
		1-D14								
		2-D10								
S P A N		30.0cm								
		2								
		SLAB THK. (mm)	LIVE LOAD (kgf/m ²)							
TYPE	h (mm)		0.00	300	500	800	1000	1250	1500	2000
A3- 65	65	120	S 6150	E 4900	E 4300	E 3750	E 3500	E 3200	E 3000	E 2700
A3- 70	70	125	S 6300	E 5050	E 4450	E 3850	E 3600	E 3300	E 3100	E 2800
A3- 75	75	130	S 6450	E 5150	E 4550	E 3950	E 3650	E 3400	E 3200	E 2850
A3- 80	80	135	S 6600	E 5250	E 4650	E 4050	E 3750	E 3500	E 3250	E 2950
A3- 85	85	140	S 6750	E 5350	E 4750	E 4150	E 3850	E 3550	E 3350	E 3000
A3- 90	90	145	S 6900	E 5450	E 4850	E 4200	E 3900	E 3650	E 3400	E 3050
A3- 95	95	150	S 7050	E 5550	E 4900	E 4300	E 4000	E 3700	E 3500	E 3150
A3-100	100	155	S 7150	E 5650	E 5000	E 4400	E 4100	E 3800	E 3550	E 3200
A3-105	105	160	S 7300	E 5700	E 5100	E 4450	E 4150	E 3850	E 3600	E 3250
A3-110	110	165	S 7450	E 5800	E 5150	E 4550	E 4200	E 3900	E 3650	E 3300
A3-115	115	170	E 7600	E 5900	E 5250	E 4600	E 4300	E 4000	E 3750	E 3350
A3-120	120	175	E 7650	E 5950	E 5300	E 4650	E 4350	E 4050	E 3800	E 3400
A3-125	125	180	E 7700	E 6050	E 5400	E 4750	E 4400	E 4100	E 3850	E 3450
A3-130	130	185	E 7750	E 6100	E 5450	E 4800	E 4500	E 4150	E 3900	E 3550
A3-135	135	190	E 7850	E 6150	E 5550	E 4850	E 4550	E 4250	E 3950	E 3600
A3-140	140	195	E 7900	E 6250	E 5600	E 4950	E 4600	E 4300	E 4000	E 3650
A3-145	145	200	E 7950	E 6300	E 5650	E 5000	E 4650	E 4350	E 4100	E 3700
A3-150	150	205	E 7950	E 6350	E 5700	E 5050	E 4700	E 4400	E 4150	E 3750
A3-155	155	210	E 7950	E 6400	E 5800	E 5100	E 4800	E 4450	E 4200	E 3750
A3-160	160	215	E 7950	E 6500	E 5850	E 5150	E 4850	E 4500	E 4250	E 3800
A3-165	165	220	E 7950	E 6550	E 5900	E 5200	E 4900	E 4550	E 4300	E 3850
A3-170	170	225	E 7950	E 6600	E 5950	E 5250	E 4950	E 4600	E 4350	E 3900
A3-175	175	230	E 7950	E 6650	E 6000	E 5300	E 5000	E 4650	E 4350	E 3950
A3-180	180	235	E 7950	E 6700	E 6050	E 5350	E 5050	E 4700	E 4400	E 4000
A3-185	185	240	E 7950	E 6750	E 6100	E 5400	E 5100	E 4750	E 4450	E 4050
A3-190	190	245	E 7950	E 6800	E 6150	E 5450	E 5150	E 4800	E 4500	E 4100
A3-195	195	250	E 7950	E 6850	E 6200	E 5500	E 5150	E 4850	E 4550	E 4100

Note - E : End Bar, C : Center Bar, L : S : (79p.)

철근콘크리트조			사용시 트러스테크의 허용 스펠							
A4 - TYPE			<ul style="list-style-type: none"> • : $f_{ck}=210\text{ kgf/cm}^2$ • : $f_y=5,000\text{ kgf/cm}^2$ • : 2.0 cm • : 2.5 cm • TRUSS PITCH : 200 mm • 가 : 100 kgf/m^2 							
L A T T I C E		5,6								
		1-D10								
		2-D6								
S P A N		30.0cm								
		1								
			LIVE LOAD (kgf/m ²)							
TYPE	h (mm)	SLAB THK. (mm)	0.00	300	500	800	1000	1250	1500	2000
A4- 65	65	120	C 4300	C 3200	C 2850	C 2500	C 2300	C 2150	C 2000	C 1850
A4- 70	70	125	C 4400	C 3300	C 2900	C 2550	C 2350	C 2200	C 2050	C 1850
A4- 75	75	130	C 4450	C 3350	C 2950	C 2600	C 2400	C 2250	C 2100	C 1900
A4- 80	80	135	C 4450	C 3400	C 3000	C 2650	C 2450	C 2300	C 2150	C 1950
A4- 85	85	140	C 4500	C 3450	C 3050	C 2700	C 2500	C 2350	C 2200	C 2000
A4- 90	90	145	C 4550	C 3500	C 3100	C 2700	C 2550	C 2350	C 2200	C 2000
A4- 95	95	150	C 4600	C 3550	C 3150	C 2750	C 2600	C 2400	C 2250	C 2050
A4-100	100	155	C 4650	C 3600	C 3200	C 2800	C 2600	C 2450	C 2300	C 2100
A4-105	105	160	C 4650	C 3600	C 3250	C 2850	C 2650	C 2500	C 2350	C 2100
A4-110	110	165	C 4700	C 3650	C 3300	C 2900	C 2700	C 2500	C 2350	C 2150
A4-115	115	170	C 4750	C 3700	C 3300	C 2900	C 2750	C 2550	C 2400	C 2150
A4-120	120	175	C 4750	C 3750	C 3350	C 2950	C 2750	C 2600	C 2450	C 2200
A4-125	125	180	C 4800	C 3800	C 3400	C 3000	C 2800	C 2600	C 2450	C 2250
A4-130	130	185	C 4800	C 3800	C 3450	C 3050	C 2850	C 2650	C 2500	C 2250
A4-135	135	190	C 4850	C 3850	C 3450	C 3050	C 2850	C 2700	C 2500	C 2300
A4-140	140	195	C 4850	C 3900	C 3500	C 3100	C 2900	C 2700	C 2550	C 2300
A4-145	145	200	C 4900	C 3900	C 3550	C 3150	C 2950	C 2750	C 2600	C 2350
A4-150	150	205	C 4900	C 3950	C 3550	C 3150	C 2950	C 2750	C 2600	C 2350
A4-155	155	210	C 4950	C 4000	C 3600	C 3200	C 3000	C 2800	C 2650	C 2400
A4-160	160	215	C 4950	C 4000	C 3600	C 3200	C 3000	C 2800	C 2650	C 2400
A4-165	165	220	C 5000	C 4050	C 3650	C 3250	C 3050	C 2850	C 2700	C 2450
A4-170	170	225	C 5000	C 4050	C 3700	C 3300	C 3100	C 2850	C 2700	C 2450
A4-175	175	230	C 5000	C 4100	C 3700	C 3300	C 3100	C 2900	C 2750	C 2500
A4-180	180	235	C 5050	C 4100	C 3750	C 3350	C 3150	C 2950	C 2750	C 2500
A4-185	185	240	C 5050	C 4150	C 3750	C 3350	C 3150	C 2950	C 2800	C 2550
A4-190	190	245	C 5050	C 4150	C 3800	C 3400	C 3200	C 3000	C 2800	C 2550
A4-195	195	250	C 5100	C 4200	C 3800	C 3400	C 3200	C 3000	C 2850	C 2600

Note - E : End Bar, C : Center Bar, L : S : (79p.)

철근콘크리트조			사용시 트러스데크의 허용 스펠							
A4 - TYPE			<ul style="list-style-type: none"> • : $f_{ck}=210\text{ kgf/cm}^2$ • : $f_y=5,000\text{ kgf/cm}^2$ • : 2.0 cm • : 2.5 cm • TRUSS PITCH : 200 mm • 가 : 100 kgf/m^2 							
L A T T I C E		5,6 1-D10 2-D6 30.0cm								
S P A N		2								
		SLAB THK. (mm)	LIVE LOAD (kgf/m ²)							
TYPE	h (mm)		0.00	300	500	800	1000	1250	1500	2000
A4- 65	65	120	E 5050	E 3750	E 3300	E 2900	E 2700	E 2500	E 2350	E 2100
A4- 70	70	125	E 5150	E 3850	E 3400	E 2950	E 2750	E 2550	E 2400	E 2150
A4- 75	75	130	E 5200	E 3900	E 3450	E 3000	E 2800	E 2600	E 2450	E 2200
A4- 80	80	135	E 5300	E 4000	E 3550	E 3100	E 2900	E 2650	E 2500	E 2250
A4- 85	85	140	E 5350	E 4050	E 3600	E 3150	E 2950	E 2700	E 2550	E 2300
A4- 90	90	145	E 5400	E 4100	E 3650	E 3200	E 3000	E 2800	E 2600	E 2350
A4- 95	95	150	E 5450	E 4200	E 3700	E 3250	E 3050	E 2850	E 2650	E 2400
A4-100	100	155	E 5500	E 4250	E 3800	E 3300	E 3100	E 2900	E 2700	E 2450
A4-105	105	160	E 5550	E 4300	E 3850	E 3350	E 3150	E 2900	E 2750	E 2500
A4-110	110	165	E 5600	E 4350	E 3900	E 3400	E 3200	E 2950	E 2800	E 2500
A4-115	115	170	E 5650	E 4400	E 3950	E 3450	E 3250	E 3000	E 2850	E 2550
A4-120	120	175	E 5700	E 4450	E 4000	E 3500	E 3300	E 3050	E 2850	E 2600
A4-125	125	180	E 5750	E 4500	E 4050	E 3550	E 3350	E 3100	E 2900	E 2650
A4-130	130	185	E 5800	E 4550	E 4100	E 3600	E 3350	E 3150	E 2950	E 2650
A4-135	135	190	E 5800	E 4600	E 4150	E 3650	E 3400	E 3200	E 3000	E 2700
A4-140	140	195	E 5850	E 4650	E 4200	E 3700	E 3450	E 3200	E 3050	E 2750
A4-145	145	200	E 5900	E 4700	E 4200	E 3750	E 3500	E 3250	E 3050	E 2800
A4-150	150	205	E 5900	E 4750	E 4250	E 3800	E 3550	E 3300	E 3100	E 2800
A4-155	155	210	E 5950	E 4750	E 4300	E 3800	E 3550	E 3350	E 3150	E 2850
A4-160	160	215	E 6000	E 4800	E 4350	E 3850	E 3600	E 3350	E 3150	E 2850
A4-165	165	220	E 6000	E 4850	E 4400	E 3900	E 3650	E 3400	E 3200	E 2900
A4-170	170	225	E 6050	E 4900	E 4400	E 3950	E 3700	E 3450	E 3250	E 2950
A4-175	175	230	E 6050	E 4900	E 4450	E 3950	E 3700	E 3450	E 3250	E 2950
A4-180	180	235	E 6100	E 4950	E 4500	E 4000	E 3750	E 3500	E 3300	E 3000
A4-185	185	240	E 6100	E 5000	E 4550	E 4050	E 3800	E 3550	E 3350	E 3050
A4-190	190	245	E 6150	E 5000	E 4550	E 4050	E 3800	E 3550	E 3350	E 3050
A4-195	195	250	E 6150	E 5050	E 4600	E 4100	E 3850	E 3600	E 3400	E 3100

Note - E : End Bar, C : Center Bar, L : S : (79p.)

철근콘크리트조			사용시 트러스테크의 허용 스펠							
A5 - TYPE			<ul style="list-style-type: none"> • $f_{ck}=210\text{ kgf/cm}^2$ • $f_y=5,000\text{ kgf/cm}^2$ • : 2.0 cm • : 2.5 cm • TRUSS PITCH : 200 mm • 가 : 100 kgf/m^2 							
L A T T I C E		5,6								
		1-D12								
		2-D7								
S P A N		30.0cm								
		1								
			LIVE LOAD (kgf/m ²)							
TYPE	h (mm)	SLAB THK. (mm)	0.00	300	500	800	1000	1250	1500	2000
A5- 65	65	120	S 4650	C 3650	C 3250	C 2800	C 2600	C 2450	C 2300	C 2050
A5- 70	70	125	S 4800	C 3750	C 3300	C 2900	C 2700	C 2500	C 2350	C 2100
A5- 75	75	130	S 4900	C 3800	C 3350	C 2950	C 2750	C 2550	C 2400	C 2150
A5- 80	80	135	S 5000	C 3850	C 3400	C 3000	C 2800	C 2600	C 2450	C 2200
A5- 85	85	140	S 5100	C 3900	C 3500	C 3050	C 2850	C 2650	C 2500	C 2250
A5- 90	90	145	C 5200	C 4000	C 3550	C 3100	C 2900	C 2700	C 2500	C 2300
A5- 95	95	150	C 5250	C 4050	C 3600	C 3150	C 2950	C 2750	C 2550	C 2300
A5-100	100	155	C 5300	C 4100	C 3650	C 3200	C 3000	C 2750	C 2600	C 2350
A5-105	105	160	C 5350	C 4150	C 3700	C 3250	C 3050	C 2800	C 2650	C 2400
A5-110	110	165	C 5400	C 4200	C 3750	C 3300	C 3050	C 2850	C 2700	C 2450
A5-115	115	170	C 5450	C 4250	C 3800	C 3350	C 3100	C 2900	C 2750	C 2450
A5-120	120	175	C 5450	C 4300	C 3850	C 3400	C 3150	C 2950	C 2750	C 2500
A5-125	125	180	C 5500	C 4350	C 3900	C 3400	C 3200	C 3000	C 2800	C 2550
A5-130	130	185	C 5550	C 4350	C 3900	C 3450	C 3250	C 3000	C 2850	C 2550
A5-135	135	190	C 5550	C 4400	C 3950	C 3500	C 3250	C 3050	C 2850	C 2600
A5-140	140	195	C 5600	C 4450	C 4000	C 3550	C 3300	C 3100	C 2900	C 2650
A5-145	145	200	C 5650	C 4500	C 4050	C 3600	C 3350	C 3100	C 2950	C 2650
A5-150	150	205	C 5650	C 4500	C 4100	C 3600	C 3400	C 3150	C 2950	C 2700
A5-155	155	210	C 5700	C 4550	C 4100	C 3650	C 3400	C 3200	C 3000	C 2700
A5-160	160	215	C 5700	C 4600	C 4150	C 3700	C 3450	C 3200	C 3050	C 2750
A5-165	165	220	C 5750	C 4650	C 4200	C 3700	C 3500	C 3250	C 3050	C 2800
A5-170	170	225	C 5750	C 4650	C 4200	C 3750	C 3500	C 3300	C 3100	C 2800
A5-175	175	230	C 5750	C 4700	C 4250	C 3800	C 3550	C 3300	C 3150	C 2850
A5-180	180	235	C 5800	C 4700	C 4300	C 3800	C 3600	C 3350	C 3150	C 2850
A5-185	185	240	C 5800	C 4750	C 4300	C 3850	C 3600	C 3350	C 3200	C 2900
A5-190	190	245	C 5850	C 4800	C 4350	C 3850	C 3650	C 3400	C 3200	C 2900
A5-195	195	250	C 5850	C 4800	C 4350	C 3900	C 3650	C 3450	C 3250	C 2950

Note - E : End Bar, C : Center Bar, L : (79p.)

철근콘크리트조			사용시 트러스데크의 허용 스펠							
A5 - TYPE			<ul style="list-style-type: none"> • : $f_{ck}=210\text{ kgf/cm}^2$ • : $f_y=5,000\text{ kgf/cm}^2$ • : 2.0 cm • : 2.5 cm • TRUSS PITCH : 200 mm • 가 : 100 kgf/m^2 							
L A T T I C E		5,6 1-D12 2-D7 30.0cm								
S P A N		2								
		SLAB THK. (mm)	LIVE LOAD (kgf/m ²)							
TYPE	h (mm)		0.00	300	500	800	1000	1250	1500	2000
A5- 65	65	120	E 5900	E 4350	E 3850	E 3350	E 3100	E 2850	E 2700	E 2400
A5- 70	70	125	E 6000	E 4450	E 3950	E 3400	E 3200	E 2950	E 2750	E 2500
A5- 75	75	130	E 6100	E 4550	E 4000	E 3500	E 3250	E 3000	E 2850	E 2550
A5- 80	80	135	E 6150	E 4650	E 4100	E 3600	E 3350	E 3100	E 2900	E 2600
A5- 85	85	140	E 6250	E 4750	E 4200	E 3650	E 3400	E 3150	E 2950	E 2650
A5- 90	90	145	E 6350	E 4800	E 4250	E 3750	E 3450	E 3200	E 3000	E 2700
A5- 95	95	150	E 6400	E 4900	E 4350	E 3800	E 3550	E 3300	E 3100	E 2750
A5-100	100	155	E 6450	E 4950	E 4400	E 3850	E 3600	E 3350	E 3150	E 2800
A5-105	105	160	E 6550	E 5050	E 4500	E 3950	E 3650	E 3400	E 3200	E 2850
A5-110	110	165	E 6600	E 5100	E 4550	E 4000	E 3700	E 3450	E 3250	E 2900
A5-115	115	170	E 6650	E 5150	E 4600	E 4050	E 3800	E 3500	E 3300	E 2950
A5-120	120	175	E 6700	E 5250	E 4650	E 4100	E 3850	E 3550	E 3350	E 3000
A5-125	125	180	E 6750	E 5300	E 4750	E 4150	E 3900	E 3600	E 3400	E 3050
A5-130	130	185	E 6800	E 5350	E 4800	E 4200	E 3950	E 3650	E 3450	E 3100
A5-135	135	190	E 6850	E 5400	E 4850	E 4250	E 4000	E 3700	E 3500	E 3150
A5-140	140	195	E 6900	E 5450	E 4900	E 4300	E 4050	E 3750	E 3550	E 3200
A5-145	145	200	E 6950	E 5500	E 4950	E 4400	E 4100	E 3800	E 3600	E 3250
A5-150	150	205	E 6950	E 5550	E 5000	E 4400	E 4150	E 3850	E 3650	E 3300
A5-155	155	210	E 7000	E 5600	E 5050	E 4450	E 4200	E 3900	E 3650	E 3300
A5-160	160	215	E 7050	E 5650	E 5100	E 4500	E 4250	E 3950	E 3700	E 3350
A5-165	165	220	E 7100	E 5700	E 5150	E 4550	E 4300	E 4000	E 3750	E 3400
A5-170	170	225	E 7100	E 5750	E 5200	E 4600	E 4300	E 4050	E 3800	E 3450
A5-175	175	230	E 7150	E 5800	E 5250	E 4650	E 4350	E 4050	E 3850	E 3450
A5-180	180	235	E 7200	E 5850	E 5300	E 4700	E 4400	E 4100	E 3850	E 3500
A5-185	185	240	E 7200	E 5900	E 5300	E 4750	E 4450	E 4150	E 3900	E 3550
A5-190	190	245	E 7250	E 5900	E 5350	E 4800	E 4500	E 4200	E 3950	E 3550
A5-195	195	250	E 7250	E 5950	E 5400	E 4800	E 4500	E 4200	E 4000	E 3600

Note - E : End Bar, C : Center Bar, L : S : (79p.)

철근콘크리트조			사용시 트러스테크의 허용 스펠							
A6 - TYPE			<ul style="list-style-type: none"> • : $f_{ck}=210\text{ kgf/cm}^2$ • : $f_y=5,000\text{ kgf/cm}^2$ • : 2.0 cm • : 2.5 cm • TRUSS PITCH : 200 mm • 가 : 100 kgf/m^2 							
L A T T I C E		5,6								
		1-D14								
		2-D8								
S P A N		30.0cm								
		1								
			LIVE LOAD (kgf/m ²)							
TYPE	h (mm)	SLAB THK. (mm)	0.00	300	500	800	1000	1250	1500	2000
A6- 65	65	120	S 4750	S 3800	L 3500	C 3150	C 2900	C 2700	C 2550	C 2300
A6- 70	70	125	S 4850	S 3900	S 3600	C 3200	C 3000	C 2750	C 2600	C 2350
A6- 75	75	130	S 5000	S 4000	S 3700	C 3300	C 3050	C 2850	C 2650	C 2400
A6- 80	80	135	S 5100	S 4150	S 3800	C 3350	C 3100	C 2900	C 2700	C 2450
A6- 85	85	140	S 5200	S 4250	C 3900	C 3400	C 3150	C 2950	C 2750	C 2500
A6- 90	90	145	S 5300	S 4350	C 3950	C 3450	C 3250	C 3000	C 2800	C 2550
A6- 95	95	150	S 5400	S 4450	C 4000	C 3500	C 3300	C 3050	C 2850	C 2600
A6-100	100	155	S 5550	S 4550	C 4100	C 3600	C 3350	C 3100	C 2900	C 2600
A6-105	105	160	S 5650	C 4650	C 4150	C 3650	C 3400	C 3150	C 2950	C 2650
A6-110	110	165	S 5750	C 4700	C 4200	C 3700	C 3450	C 3200	C 3000	C 2700
A6-115	115	170	S 5850	C 4750	C 4250	C 3750	C 3500	C 3250	C 3050	C 2750
A6-120	120	175	S 5950	C 4800	C 4300	C 3800	C 3550	C 3300	C 3100	C 2800
A6-125	125	180	S 6050	C 4850	C 4350	C 3850	C 3600	C 3350	C 3150	C 2850
A6-130	130	185	S 6150	C 4900	C 4400	C 3900	C 3650	C 3400	C 3200	C 2850
A6-135	135	190	S 6250	C 4950	C 4450	C 3950	C 3650	C 3400	C 3200	C 2900
A6-140	140	195	C 6300	C 5000	C 4500	C 3950	C 3700	C 3450	C 3250	C 2950
A6-145	145	200	C 6350	C 5050	C 4550	C 4000	C 3750	C 3500	C 3300	C 3000
A6-150	150	205	C 6400	C 5100	C 4600	C 4050	C 3800	C 3550	C 3350	C 3000
A6-155	155	210	C 6400	C 5150	C 4650	C 4100	C 3850	C 3600	C 3350	C 3050
A6-160	160	215	C 6450	C 5200	C 4650	C 4150	C 3900	C 3600	C 3400	C 3100
A6-165	165	220	C 6450	C 5200	C 4700	C 4200	C 3900	C 3650	C 3450	C 3100
A6-170	170	225	C 6500	C 5250	C 4750	C 4200	C 3950	C 3700	C 3450	C 3150
A6-175	175	230	C 6500	C 5300	C 4800	C 4250	C 4000	C 3700	C 3500	C 3200
A6-180	180	235	C 6550	C 5300	C 4800	C 4300	C 4000	C 3750	C 3550	C 3200
A6-185	185	240	C 6550	C 5350	C 4850	C 4350	C 4050	C 3800	C 3550	C 3250
A6-190	190	245	C 6600	C 5400	C 4900	C 4350	C 4100	C 3800	C 3600	C 3250
A6-195	195	250	C 6600	C 5400	C 4950	C 4400	C 4150	C 3850	C 3650	C 3300

Note - E : End Bar, C : Center Bar, L : (79p.)

철근콘크리트조				사용시 트러스데크의 허용 스펠							
A6 - TYPE				<ul style="list-style-type: none"> • : $f_{ck}=210\text{ kgf/cm}^2$ • : $f_y=5,000\text{ kgf/cm}^2$ • : 2.0 cm • : 2.5 cm • TRUSS PITCH : 200 mm • 가 : 100 kgf/m^2 							
L A T T I C E		5,6 1-D14 2-D8 30.0cm									
S P A N		2									
			SLAB THK. (mm)	LIVE LOAD (kgf/m ²)							
TYPE	h (mm)	SLAB THK. (mm)	0.00	300	500	800	1000	1250	1500	2000	
A6- 65	65	120	S 6100	S 4850	E 4300	E 3750	E 3500	E 3200	E 3000	E 2700	
A6- 70	70	125	S 6250	S 5000	E 4450	E 3850	E 3600	E 3300	E 3100	E 2800	
A6- 75	75	130	S 6400	E 5150	E 4550	E 3950	E 3650	E 3400	E 3200	E 2850	
A6- 80	80	135	S 6550	E 5250	E 4650	E 4050	E 3750	E 3500	E 3250	E 2950	
A6- 85	85	140	S 6650	E 5350	E 4750	E 4150	E 3850	E 3550	E 3350	E 3000	
A6- 90	90	145	S 6800	E 5450	E 4850	E 4200	E 3900	E 3650	E 3400	E 3050	
A6- 95	95	150	S 6950	E 5550	E 4900	E 4300	E 4000	E 3700	E 3500	E 3150	
A6-100	100	155	S 7100	E 5650	E 5000	E 4400	E 4100	E 3800	E 3550	E 3200	
A6-105	105	160	S 7200	E 5700	E 5100	E 4450	E 4150	E 3850	E 3600	E 3250	
A6-110	110	165	S 7350	E 5800	E 5150	E 4550	E 4200	E 3900	E 3650	E 3300	
A6-115	115	170	S 7500	E 5900	E 5250	E 4600	E 4300	E 4000	E 3750	E 3350	
A6-120	120	175	S 7600	E 5950	E 5300	E 4650	E 4350	E 4050	E 3800	E 3400	
A6-125	125	180	E 7700	E 6050	E 5400	E 4750	E 4400	E 4100	E 3850	E 3450	
A6-130	130	185	E 7750	E 6100	E 5450	E 4800	E 4500	E 4150	E 3900	E 3550	
A6-135	135	190	E 7850	E 6150	E 5550	E 4850	E 4550	E 4250	E 3950	E 3600	
A6-140	140	195	E 7900	E 6250	E 5600	E 4950	E 4600	E 4300	E 4000	E 3650	
A6-145	145	200	E 7950	E 6300	E 5650	E 5000	E 4650	E 4350	E 4100	E 3700	
A6-150	150	205	E 7950	E 6350	E 5700	E 5050	E 4700	E 4400	E 4150	E 3750	
A6-155	155	210	E 7950	E 6400	E 5800	E 5100	E 4800	E 4450	E 4200	E 3750	
A6-160	160	215	E 7950	E 6500	E 5850	E 5150	E 4850	E 4500	E 4250	E 3800	
A6-165	165	220	E 7950	E 6550	E 5900	E 5200	E 4900	E 4550	E 4300	E 3850	
A6-170	170	225	E 7950	E 6600	E 5950	E 5250	E 4950	E 4600	E 4350	E 3900	
A6-175	175	230	E 7950	E 6650	E 6000	E 5300	E 5000	E 4650	E 4350	E 3950	
A6-180	180	235	E 7950	E 6700	E 6050	E 5350	E 5050	E 4700	E 4400	E 4000	
A6-185	185	240	E 7950	E 6750	E 6100	E 5400	E 5100	E 4750	E 4450	E 4050	
A6-190	190	245	E 7950	E 6800	E 6150	E 5450	E 5150	E 4800	E 4500	E 4100	
A6-195	195	250	E 7950	E 6850	E 6200	E 5500	E 5150	E 4850	E 4550	E 4100	

Note - E : End Bar, C : Center Bar, L : S : (79p.)

철 골 조			사용시 트러스테크의 허용 스펠							
A1 - TYPE			<ul style="list-style-type: none"> • : $f_{ck}=210\text{ kgf/cm}^2$ • : $f_y=5,000\text{ kgf/cm}^2$ • : 2.0 cm • : 2.5 cm • TRUSS PITCH : 200 mm • 가 : 100 kgf/m^2 							
L A T T I C E		5,6								
		1-D10								
		2-D7								
S P A N		20.0cm								
		1								
			LIVE LOAD (kgf/m ²)							
TYPE	h (mm)	SLAB THK. (mm)	0.00	300	500	800	1000	1250	1500	2000
A1- 65	65	120	S 4300	C 3350	C 2950	C 2500	C 2300	C 2150	C 2000	C 1750
A1- 70	70	125	S 4450	C 3450	C 3000	C 2600	C 2400	C 2200	C 2050	C 1800
A1- 75	75	130	S 4550	C 3500	C 3050	C 2650	C 2450	C 2250	C 2100	C 1850
A1- 80	80	135	S 4650	C 3550	C 3100	C 2700	C 2500	C 2300	C 2150	C 1900
A1- 85	85	140	S 4800	C 3600	C 3200	C 2750	C 2550	C 2350	C 2200	C 1950
A1- 90	90	145	C 4900	C 3700	C 3250	C 2800	C 2600	C 2400	C 2200	C 2000
A1- 95	95	150	C 4950	C 3750	C 3300	C 2850	C 2650	C 2450	C 2250	C 2000
A1-100	100	155	C 5000	C 3800	C 3350	C 2900	C 2700	C 2450	C 2300	C 2050
A1-105	105	160	C 5050	C 3850	C 3400	C 2950	C 2750	C 2500	C 2350	C 2100
A1-110	110	165	C 5100	C 3900	C 3450	C 3000	C 2750	C 2550	C 2400	C 2150
A1-115	115	170	C 5150	C 3950	C 3500	C 3050	C 2800	C 2600	C 2450	C 2150
A1-120	120	175	C 5150	C 4000	C 3550	C 3100	C 2850	C 2650	C 2450	C 2200
A1-125	125	180	C 5200	C 4050	C 3600	C 3100	C 2900	C 2700	C 2500	C 2250
A1-130	130	185	C 5250	C 4050	C 3600	C 3150	C 2950	C 2700	C 2550	C 2250
A1-135	135	190	C 5250	C 4100	C 3650	C 3200	C 2950	C 2750	C 2550	C 2300
A1-140	140	195	C 5300	C 4150	C 3700	C 3250	C 3000	C 2800	C 2600	C 2350
A1-145	145	200	C 5350	C 4200	C 3750	C 3300	C 3050	C 2800	C 2650	C 2350
A1-150	150	205	C 5350	C 4200	C 3800	C 3300	C 3100	C 2850	C 2650	C 2400
A1-155	155	210	C 5400	C 4250	C 3800	C 3350	C 3100	C 2900	C 2700	C 2400
A1-160	160	215	C 5400	C 4300	C 3850	C 3400	C 3150	C 2900	C 2750	C 2450
A1-165	165	220	C 5450	C 4350	C 3900	C 3400	C 3200	C 2950	C 2750	C 2500
A1-170	170	225	C 5450	C 4350	C 3900	C 3450	C 3200	C 3000	C 2800	C 2500
A1-175	175	230	C 5450	C 4400	C 3950	C 3500	C 3250	C 3000	C 2850	C 2550
A1-180	180	235	C 5500	C 4400	C 4000	C 3500	C 3300	C 3050	C 2850	C 2550
A1-185	185	240	C 5500	C 4450	C 4000	C 3550	C 3300	C 3050	C 2900	C 2600
A1-190	190	245	C 5550	C 4500	C 4050	C 3550	C 3350	C 3100	C 2900	C 2600
A1-195	195	250	C 5550	C 4500	C 4050	C 3600	C 3350	C 3150	C 2950	C 2650

Note - E : End Bar, C : Center Bar, L : (79p.)

철 골 조			사용시 트러스데크의 허용 스펠							
A1 - TYPE			<ul style="list-style-type: none"> • : $f_{ck}=210\text{ kgf/cm}^2$ • : $f_y=5,000\text{ kgf/cm}^2$ • : 2.0 cm • : 2.5 cm • TRUSS PITCH : 200 mm • 가 : 100 kgf/m^2 							
L A T T I C E		5,6 1-D10 2-D7 20.0cm								
S P A N		2								
		SLAB THK. (mm)	LIVE LOAD (kgf/m ²)							
TYPE	h (mm)		0.00	300	500	800	1000	1250	1500	2000
A1- 65	65	120	E 4500	E 3250	E 2850	E 2450	E 2250	E 2050	E 1950	E 1700
A1- 70	70	125	E 4550	E 3350	E 2900	E 2500	E 2300	E 2150	E 2000	E 1750
A1- 75	75	130	E 4650	E 3400	E 3000	E 2550	E 2350	E 2200	E 2050	E 1800
A1- 80	80	135	E 4700	E 3500	E 3050	E 2650	E 2450	E 2250	E 2100	E 1850
A1- 85	85	140	E 4750	E 3550	E 3100	E 2700	E 2500	E 2300	E 2150	E 1900
A1- 90	90	145	E 4800	E 3600	E 3150	E 2750	E 2550	E 2350	E 2200	E 1950
A1- 95	95	150	E 4850	E 3650	E 3250	E 2800	E 2600	E 2400	E 2200	E 2000
A1-100	100	155	E 4900	E 3700	E 3300	E 2850	E 2650	E 2450	E 2250	E 2000
A1-105	105	160	E 4950	E 3800	E 3350	E 2900	E 2700	E 2450	E 2300	E 2050
A1-110	110	165	E 5000	E 3850	E 3400	E 2950	E 2750	E 2500	E 2350	E 2100
A1-115	115	170	E 5050	E 3900	E 3450	E 3000	E 2750	E 2550	E 2400	E 2150
A1-120	120	175	E 5100	E 3950	E 3500	E 3050	E 2800	E 2600	E 2450	E 2150
A1-125	125	180	E 5150	E 3950	E 3550	E 3100	E 2850	E 2650	E 2450	E 2200
A1-130	130	185	E 5150	E 4000	E 3550	E 3100	E 2900	E 2700	E 2500	E 2250
A1-135	135	190	E 5200	E 4050	E 3600	E 3150	E 2950	E 2700	E 2550	E 2250
A1-140	140	195	E 5250	E 4100	E 3650	E 3200	E 3000	E 2750	E 2600	E 2300
A1-145	145	200	E 5250	E 4150	E 3700	E 3250	E 3000	E 2800	E 2600	E 2350
A1-150	150	205	E 5300	E 4200	E 3750	E 3300	E 3050	E 2850	E 2650	E 2350
A1-155	155	210	E 5350	E 4200	E 3800	E 3300	E 3100	E 2850	E 2700	E 2400
A1-160	160	215	E 5350	E 4250	E 3800	E 3350	E 3100	E 2900	E 2700	E 2450
A1-165	165	220	E 5400	E 4300	E 3850	E 3400	E 3150	E 2950	E 2750	E 2450
A1-170	170	225	E 5400	E 4350	E 3900	E 3400	E 3200	E 2950	E 2750	E 2500
A1-175	175	230	E 5450	E 4350	E 3900	E 3450	E 3200	E 3000	E 2800	E 2500
A1-180	180	235	E 5450	E 4400	E 3950	E 3500	E 3250	E 3000	E 2850	E 2550
A1-185	185	240	E 5500	E 4400	E 4000	E 3500	E 3300	E 3050	E 2850	E 2550
A1-190	190	245	E 5500	E 4450	E 4000	E 3550	E 3300	E 3100	E 2900	E 2600
A1-195	195	250	E 5500	E 4500	E 4050	E 3600	E 3350	E 3100	E 2900	E 2600

Note - E : End Bar, C : Center Bar, L : S : (79p.)

철 골 조			사용시 트러스테크의 허용 스펠							
A2 - TYPE			<ul style="list-style-type: none"> • : $f_{ck}=210\text{ kgf/cm}^2$ • : $f_y=5,000\text{ kgf/cm}^2$ • : 2.0 cm • : 2.5 cm • TRUSS PITCH : 200 mm • 가 : 100 kgf/m^2 							
L A T T I C E		5,6								
		1-D12								
		2-D8								
S P A N		20.0cm								
		1								
			LIVE LOAD (kgf/m ²)							
TYPE	h (mm)	SLAB THK. (mm)	0.00	300	500	800	1000	1250	1500	2000
A2- 65	65	120	S 4400	S 3450	S 3150	S 2800	C 2600	C 2400	C 2250	C 2000
A2- 70	70	125	S 4500	S 3600	S 3250	C 2900	C 2700	C 2450	C 2300	C 2050
A2- 75	75	130	S 4600	S 3700	S 3350	C 3000	C 2750	C 2550	C 2350	C 2100
A2- 80	80	135	S 4750	S 3800	S 3450	C 3050	C 2800	C 2600	C 2400	C 2150
A2- 85	85	140	S 4850	S 3900	C 3600	C 3100	C 2850	C 2650	C 2450	C 2200
A2- 90	90	145	S 4950	S 4000	C 3650	C 3150	C 2950	C 2700	C 2500	C 2250
A2- 95	95	150	S 5050	S 4100	C 3700	C 3200	C 3000	C 2750	C 2550	C 2300
A2-100	100	155	S 5150	S 4200	C 3800	C 3300	C 3050	C 2800	C 2600	C 2300
A2-105	105	160	S 5300	C 4350	C 3850	C 3350	C 3100	C 2850	C 2650	C 2350
A2-110	110	165	S 5400	C 4400	C 3900	C 3400	C 3150	C 2900	C 2700	C 2400
A2-115	115	170	S 5500	C 4450	C 3950	C 3450	C 3200	C 2950	C 2750	C 2450
A2-120	120	175	S 5600	C 4500	C 4000	C 3500	C 3250	C 3000	C 2800	C 2500
A2-125	125	180	S 5700	C 4550	C 4050	C 3550	C 3300	C 3050	C 2850	C 2550
A2-130	130	185	S 5800	C 4600	C 4100	C 3600	C 3350	C 3100	C 2900	C 2550
A2-135	135	190	S 5900	C 4650	C 4150	C 3650	C 3350	C 3100	C 2900	C 2600
A2-140	140	195	S 5950	C 4700	C 4200	C 3650	C 3400	C 3150	C 2950	C 2650
A2-145	145	200	C 6050	C 4750	C 4250	C 3700	C 3450	C 3200	C 3000	C 2700
A2-150	150	205	C 6100	C 4800	C 4300	C 3750	C 3500	C 3250	C 3050	C 2700
A2-155	155	210	C 6100	C 4850	C 4350	C 3800	C 3550	C 3300	C 3050	C 2750
A2-160	160	215	C 6150	C 4900	C 4350	C 3850	C 3600	C 3300	C 3100	C 2800
A2-165	165	220	C 6150	C 4900	C 4400	C 3900	C 3600	C 3350	C 3150	C 2800
A2-170	170	225	C 6200	C 4950	C 4450	C 3900	C 3650	C 3400	C 3150	C 2850
A2-175	175	230	C 6200	C 5000	C 4500	C 3950	C 3700	C 3400	C 3200	C 2900
A2-180	180	235	C 6250	C 5000	C 4500	C 4000	C 3700	C 3450	C 3250	C 2900
A2-185	185	240	C 6250	C 5050	C 4550	C 4050	C 3750	C 3500	C 3250	C 2950
A2-190	190	245	C 6300	C 5100	C 4600	C 4050	C 3800	C 3500	C 3300	C 2950
A2-195	195	250	C 6300	C 5100	C 4650	C 4100	C 3850	C 3550	C 3350	C 3000

Note - E : End Bar, C : Center Bar, L : (79p.)

철 골 조			사용시 트러스데크의 허용 스펠							
A2 - TYPE			<ul style="list-style-type: none"> • : $f_{ck}=210\text{ kgf/cm}^2$ • : $f_y=5,000\text{ kgf/cm}^2$ • : 2.0 cm • : 2.5 cm • TRUSS PITCH : 200 mm • 가 : 100 kgf/m^2 							
L A T T I C E		5,6 1-D12 2-D8 20.0cm								
S P A N		2								
		SLAB THK. (mm)	LIVE LOAD (kgf/m ²)							
TYPE	h (mm)		0.00	300	500	800	1000	1250	1500	2000
A2- 65	65	120	E 5300	E 3850	E 3350	E 2850	E 2650	E 2450	E 2250	E 2000
A2- 70	70	125	E 5350	E 3900	E 3450	E 2950	E 2700	E 2500	E 2300	E 2050
A2- 75	75	130	E 5450	E 4000	E 3500	E 3000	E 2800	E 2550	E 2400	E 2100
A2- 80	80	135	E 5550	E 4100	E 3600	E 3100	E 2850	E 2650	E 2450	E 2200
A2- 85	85	140	E 5600	E 4150	E 3650	E 3150	E 2900	E 2700	E 2500	E 2250
A2- 90	90	145	E 5700	E 4250	E 3750	E 3250	E 3000	E 2750	E 2550	E 2300
A2- 95	95	150	E 5750	E 4300	E 3800	E 3300	E 3050	E 2800	E 2600	E 2350
A2-100	100	155	E 5800	E 4400	E 3900	E 3350	E 3100	E 2850	E 2650	E 2400
A2-105	105	160	E 5900	E 4450	E 3950	E 3400	E 3150	E 2900	E 2750	E 2450
A2-110	110	165	E 5950	E 4550	E 4000	E 3500	E 3250	E 3000	E 2800	E 2500
A2-115	115	170	E 6000	E 4600	E 4050	E 3550	E 3300	E 3050	E 2850	E 2500
A2-120	120	175	E 6050	E 4650	E 4100	E 3600	E 3350	E 3100	E 2850	E 2550
A2-125	125	180	E 6100	E 4700	E 4200	E 3650	E 3400	E 3150	E 2900	E 2600
A2-130	130	185	E 6150	E 4750	E 4250	E 3700	E 3450	E 3150	E 2950	E 2650
A2-135	135	190	E 6150	E 4800	E 4300	E 3750	E 3500	E 3200	E 3000	E 2700
A2-140	140	195	E 6200	E 4850	E 4350	E 3800	E 3550	E 3250	E 3050	E 2750
A2-145	145	200	E 6250	E 4900	E 4400	E 3850	E 3600	E 3300	E 3100	E 2750
A2-150	150	205	E 6300	E 4950	E 4450	E 3900	E 3600	E 3350	E 3150	E 2800
A2-155	155	210	E 6350	E 5000	E 4500	E 3950	E 3650	E 3400	E 3200	E 2850
A2-160	160	215	E 6350	E 5050	E 4550	E 4000	E 3700	E 3450	E 3200	E 2900
A2-165	165	220	E 6400	E 5100	E 4550	E 4000	E 3750	E 3500	E 3250	E 2900
A2-170	170	225	E 6450	E 5150	E 4600	E 4050	E 3800	E 3500	E 3300	E 2950
A2-175	175	230	E 6450	E 5200	E 4650	E 4100	E 3850	E 3550	E 3350	E 3000
A2-180	180	235	E 6500	E 5200	E 4700	E 4150	E 3850	E 3600	E 3350	E 3000
A2-185	185	240	E 6500	E 5250	E 4750	E 4200	E 3900	E 3650	E 3400	E 3050
A2-190	190	245	E 6550	E 5300	E 4800	E 4200	E 3950	E 3650	E 3450	E 3100
A2-195	195	250	E 6550	E 5350	E 4800	E 4250	E 4000	E 3700	E 3450	E 3100

Note - E : End Bar, C : Center Bar, L : S : (79p.)

철 골 조			사용시 트러스테크의 허용 스펠							
A3 - TYPE			<ul style="list-style-type: none"> • : $f_{ck}=210\text{ kgf/cm}^2$ • : $f_y=5,000\text{ kgf/cm}^2$ • : 2.0 cm • : 2.5 cm • TRUSS PITCH : 200 mm • 가 : 100 kgf/m^2 							
L A T T I C E		5,6								
		1-D14								
		2-D10								
S P A N		20.0cm								
		1								
			LIVE LOAD (kgf/m ²)							
TYPE	h (mm)	SLAB THK. (mm)	0.00	300	500	800	1000	1250	1500	2000
A3- 65	65	120	S 4500	S 3550	S 3250	L 2900	L 2750	L 2550	L 2400	L 2200
A3- 70	70	125	S 4650	S 3650	S 3350	S 3000	S 2800	L 2650	L 2500	L 2300
A3- 75	75	130	S 4750	S 3750	S 3450	S 3100	S 2900	L 2750	L 2600	L 2350
A3- 80	80	135	S 4850	S 3900	S 3550	S 3200	S 3000	L 2850	L 2700	L 2450
A3- 85	85	140	S 5000	S 4000	S 3650	S 3300	S 3100	L 2950	L 2800	L 2550
A3- 90	90	145	S 5100	S 4100	S 3750	S 3400	S 3200	S 3000	L 2850	L 2600
A3- 95	95	150	S 5200	S 4200	S 3850	S 3500	S 3300	S 3100	L 2950	L 2700
A3-100	100	155	S 5300	S 4300	S 3950	S 3600	S 3400	L 3200	L 3050	L 2750
A3-105	105	160	S 5400	S 4400	S 4050	S 3700	S 3500	L 3300	S 3100	L 2850
A3-110	110	165	S 5500	S 4500	S 4150	S 3750	S 3550	S 3350	L 3200	C 2950
A3-115	115	170	S 5600	S 4600	S 4250	S 3850	S 3650	S 3450	L 3300	C 3000
A3-120	120	175	S 5700	S 4700	S 4350	S 3950	S 3750	S 3550	S 3350	C 3050
A3-125	125	180	S 5800	S 4800	S 4450	S 4050	S 3850	S 3600	C 3450	C 3100
A3-130	130	185	S 5900	S 4900	S 4550	S 4150	S 3950	S 3700	C 3550	C 3150
A3-135	135	190	S 6000	S 5000	S 4650	S 4200	S 4000	S 3800	C 3600	C 3200
A3-140	140	195	S 6100	S 5100	S 4750	S 4300	S 4100	S 3850	C 3650	C 3250
A3-145	145	200	S 6200	S 5200	S 4800	S 4400	S 4200	C 3950	C 3700	C 3300
A3-150	150	205	S 6300	S 5300	S 4900	S 4500	S 4250	C 4000	C 3750	C 3350
A3-155	155	210	S 6400	S 5400	S 5000	S 4550	C 4350	C 4050	C 3750	C 3400
A3-160	160	215	S 6500	S 5450	S 5100	S 4650	C 4400	C 4100	C 3800	C 3400
A3-165	165	220	S 6550	S 5550	S 5150	C 4750	C 4450	C 4150	C 3850	C 3450
A3-170	170	225	S 6650	S 5650	S 5250	C 4800	C 4500	C 4150	C 3900	C 3500
A3-175	175	230	S 6750	S 5750	S 5350	C 4850	C 4550	C 4200	C 3950	C 3550
A3-180	180	235	S 6850	S 5850	S 5450	C 4900	C 4600	C 4250	C 4000	C 3600
A3-185	185	240	S 6950	S 5900	S 5500	C 4950	C 4650	C 4300	C 4050	C 3600
A3-190	190	245	S 7000	S 6000	S 5600	C 5000	C 4700	C 4350	C 4100	C 3650
A3-195	195	250	S 7100	S 6100	C 5700	C 5050	C 4700	C 4400	C 4100	C 3700

Note - E : End Bar, C : Center Bar, L : (79p.)

철 골 조			사용시 트러스데크의 허용 스펠							
A3 - TYPE			<ul style="list-style-type: none"> • : $f_{ck}=210\text{ kgf/cm}^2$ • : $f_y=5,000\text{ kgf/cm}^2$ • : 2.0 cm • : 2.5 cm • TRUSS PITCH : 200 mm • 가 : 100 kgf/m^2 							
L A T T I C E		5,6								
		1-D14								
		2-D10								
		20.0cm								
S P A N		2								
		SLAB THK. (mm)	LIVE LOAD (kgf/m ²)							
TYPE	h (mm)		0.00	300	500	800	1000	1250	1500	2000
A3- 65	65	120	S 5850	E 4350	E 3800	E 3250	E 3000	E 2750	E 2550	E 2250
A3- 70	70	125	S 6000	E 4450	E 3900	E 3350	E 3100	E 2850	E 2650	E 2350
A3- 75	75	130	S 6150	E 4550	E 4000	E 3450	E 3200	E 2900	E 2700	E 2400
A3- 80	80	135	E 6300	E 4650	E 4100	E 3550	E 3250	E 3000	E 2800	E 2500
A3- 85	85	140	E 6400	E 4750	E 4200	E 3600	E 3350	E 3050	E 2850	E 2550
A3- 90	90	145	E 6500	E 4850	E 4250	E 3700	E 3400	E 3150	E 2950	E 2600
A3- 95	95	150	E 6600	E 4950	E 4350	E 3750	E 3500	E 3200	E 3000	E 2650
A3-100	100	155	E 6650	E 5050	E 4450	E 3850	E 3550	E 3300	E 3050	E 2750
A3-105	105	160	E 6750	E 5100	E 4500	E 3900	E 3650	E 3350	E 3100	E 2800
A3-110	110	165	E 6800	E 5200	E 4600	E 4000	E 3700	E 3400	E 3200	E 2850
A3-115	115	170	E 6850	E 5250	E 4650	E 4050	E 3750	E 3450	E 3250	E 2900
A3-120	120	175	E 6950	E 5350	E 4750	E 4100	E 3850	E 3550	E 3300	E 2950
A3-125	125	180	E 7000	E 5400	E 4800	E 4200	E 3900	E 3600	E 3350	E 3000
A3-130	130	185	E 7050	E 5450	E 4850	E 4250	E 3950	E 3650	E 3400	E 3050
A3-135	135	190	E 7100	E 5550	E 4950	E 4300	E 4000	E 3700	E 3450	E 3100
A3-140	140	195	E 7150	E 5600	E 5000	E 4350	E 4050	E 3750	E 3500	E 3150
A3-145	145	200	E 7200	E 5650	E 5050	E 4400	E 4100	E 3800	E 3550	E 3200
A3-150	150	205	E 7250	E 5700	E 5100	E 4500	E 4150	E 3850	E 3600	E 3250
A3-155	155	210	E 7300	E 5750	E 5150	E 4550	E 4200	E 3900	E 3650	E 3300
A3-160	160	215	E 7350	E 5800	E 5200	E 4600	E 4250	E 3950	E 3700	E 3300
A3-165	165	220	E 7350	E 5900	E 5250	E 4650	E 4300	E 4000	E 3750	E 3350
A3-170	170	225	E 7400	E 5950	E 5300	E 4700	E 4350	E 4050	E 3800	E 3400
A3-175	175	230	E 7450	E 6000	E 5350	E 4750	E 4400	E 4100	E 3850	E 3450
A3-180	180	235	E 7500	E 6000	E 5400	E 4800	E 4450	E 4150	E 3900	E 3500
A3-185	185	240	E 7500	E 6050	E 5450	E 4850	E 4500	E 4200	E 3950	E 3500
A3-190	190	245	E 7550	E 6100	E 5500	E 4850	E 4550	E 4250	E 3950	E 3550
A3-195	195	250	E 7600	E 6150	E 5550	E 4900	E 4600	E 4250	E 4000	E 3600

Note - E : End Bar, C : Center Bar, L : S : (79p.)

철 골 조			사용시 트러스테크의 허용 스펠							
A4 - TYPE			<ul style="list-style-type: none"> • : $f_{ck}=210\text{ kgf/cm}^2$ • : $f_y=5,000\text{ kgf/cm}^2$ • : 2.0 cm • : 2.5 cm • TRUSS PITCH : 200 mm • 가 : 100 kgf/m^2 							
L A T T I C E		5,6								
		1-D10								
		2-D6								
S P A N		20.0cm								
		1								
			LIVE LOAD (kgf/m ²)							
TYPE	h (mm)	SLAB THK. (mm)	0.00	300	500	800	1000	1250	1500	2000
A4- 65	65	120	C 4000	C 2900	C 2550	C 2200	C 2000	C 1850	C 1700	C 1550
A4- 70	70	125	C 4100	C 3000	C 2600	C 2250	C 2050	C 1900	C 1750	C 1550
A4- 75	75	130	C 4150	C 3050	C 2650	C 2300	C 2100	C 1950	C 1800	C 1600
A4- 80	80	135	C 4150	C 3100	C 2700	C 2350	C 2150	C 2000	C 1850	C 1650
A4- 85	85	140	C 4200	C 3150	C 2750	C 2400	C 2200	C 2050	C 1900	C 1700
A4- 90	90	145	C 4250	C 3200	C 2800	C 2400	C 2250	C 2050	C 1900	C 1700
A4- 95	95	150	C 4300	C 3250	C 2850	C 2450	C 2300	C 2100	C 1950	C 1750
A4-100	100	155	C 4350	C 3300	C 2900	C 2500	C 2300	C 2150	C 2000	C 1800
A4-105	105	160	C 4350	C 3300	C 2950	C 2550	C 2350	C 2200	C 2050	C 1800
A4-110	110	165	C 4400	C 3350	C 3000	C 2600	C 2400	C 2200	C 2050	C 1850
A4-115	115	170	C 4450	C 3400	C 3000	C 2600	C 2450	C 2250	C 2100	C 1850
A4-120	120	175	C 4450	C 3450	C 3050	C 2650	C 2450	C 2300	C 2150	C 1900
A4-125	125	180	C 4500	C 3500	C 3100	C 2700	C 2500	C 2300	C 2150	C 1950
A4-130	130	185	C 4500	C 3500	C 3150	C 2750	C 2550	C 2350	C 2200	C 1950
A4-135	135	190	C 4550	C 3550	C 3150	C 2750	C 2550	C 2400	C 2200	C 2000
A4-140	140	195	C 4550	C 3600	C 3200	C 2800	C 2600	C 2400	C 2250	C 2000
A4-145	145	200	C 4600	C 3600	C 3250	C 2850	C 2650	C 2450	C 2300	C 2050
A4-150	150	205	C 4600	C 3650	C 3250	C 2850	C 2650	C 2450	C 2300	C 2050
A4-155	155	210	C 4650	C 3700	C 3300	C 2900	C 2700	C 2500	C 2350	C 2100
A4-160	160	215	C 4650	C 3700	C 3300	C 2900	C 2700	C 2500	C 2350	C 2100
A4-165	165	220	C 4700	C 3750	C 3350	C 2950	C 2750	C 2550	C 2400	C 2150
A4-170	170	225	C 4700	C 3750	C 3400	C 3000	C 2800	C 2550	C 2400	C 2150
A4-175	175	230	C 4700	C 3800	C 3400	C 3000	C 2800	C 2600	C 2450	C 2200
A4-180	180	235	C 4750	C 3800	C 3450	C 3050	C 2850	C 2650	C 2450	C 2200
A4-185	185	240	C 4750	C 3850	C 3450	C 3050	C 2850	C 2650	C 2500	C 2250
A4-190	190	245	C 4750	C 3850	C 3500	C 3100	C 2900	C 2700	C 2500	C 2250
A4-195	195	250	C 4800	C 3900	C 3500	C 3100	C 2900	C 2700	C 2550	C 2300

Note - E : End Bar, C : Center Bar, L : S : (79p.)

철 골 조			사용시 트러스데크의 허용 스펠							
A4 - TYPE			<ul style="list-style-type: none"> • : $f_{ck}=210\text{ kgf/cm}^2$ • : $f_y=5,000\text{ kgf/cm}^2$ • : 2.0 cm • : 2.5 cm • TRUSS PITCH : 200 mm • 가 : 100 kgf/m^2 							
L A T T I C E		5,6 1-D10 2-D6 20.0cm								
S P A N		2								
		SLAB THK. (mm)	LIVE LOAD (kgf/m ²)							
TYPE	h (mm)		0.00	300	500	800	1000	1250	1500	2000
A4- 65	65	120	E 4500	E 3250	E 2850	E 2450	E 2250	E 2050	E 1950	E 1700
A4- 70	70	125	E 4550	E 3350	E 2900	E 2500	E 2300	E 2150	E 2000	E 1750
A4- 75	75	130	E 4650	E 3400	E 3000	E 2550	E 2350	E 2200	E 2050	E 1800
A4- 80	80	135	E 4700	E 3500	E 3050	E 2650	E 2450	E 2250	E 2100	E 1850
A4- 85	85	140	E 4750	E 3550	E 3100	E 2700	E 2500	E 2300	E 2150	E 1900
A4- 90	90	145	E 4800	E 3600	E 3150	E 2750	E 2550	E 2350	E 2200	E 1950
A4- 95	95	150	E 4850	E 3650	E 3250	E 2800	E 2600	E 2400	E 2200	E 2000
A4-100	100	155	E 4900	E 3700	E 3300	E 2850	E 2650	E 2450	E 2250	E 2000
A4-105	105	160	E 4950	E 3800	E 3350	E 2900	E 2700	E 2450	E 2300	E 2050
A4-110	110	165	E 5000	E 3850	E 3400	E 2950	E 2750	E 2500	E 2350	E 2100
A4-115	115	170	E 5050	E 3900	E 3450	E 3000	E 2750	E 2550	E 2400	E 2150
A4-120	120	175	E 5100	E 3950	E 3500	E 3050	E 2800	E 2600	E 2450	E 2150
A4-125	125	180	E 5150	E 3950	E 3550	E 3100	E 2850	E 2650	E 2450	E 2200
A4-130	130	185	E 5150	E 4000	E 3550	E 3100	E 2900	E 2700	E 2500	E 2250
A4-135	135	190	E 5200	E 4050	E 3600	E 3150	E 2950	E 2700	E 2550	E 2250
A4-140	140	195	E 5250	E 4100	E 3650	E 3200	E 3000	E 2750	E 2600	E 2300
A4-145	145	200	E 5250	E 4150	E 3700	E 3250	E 3000	E 2800	E 2600	E 2350
A4-150	150	205	E 5300	E 4200	E 3750	E 3300	E 3050	E 2850	E 2650	E 2350
A4-155	155	210	E 5350	E 4200	E 3800	E 3300	E 3100	E 2850	E 2700	E 2400
A4-160	160	215	E 5350	E 4250	E 3800	E 3350	E 3100	E 2900	E 2700	E 2450
A4-165	165	220	E 5400	E 4300	E 3850	E 3400	E 3150	E 2950	E 2750	E 2450
A4-170	170	225	E 5400	E 4350	E 3900	E 3400	E 3200	E 2950	E 2750	E 2500
A4-175	175	230	E 5450	E 4350	E 3900	E 3450	E 3200	E 3000	E 2800	E 2500
A4-180	180	235	E 5450	E 4400	E 3950	E 3500	E 3250	E 3000	E 2850	E 2550
A4-185	185	240	E 5500	E 4400	E 4000	E 3500	E 3300	E 3050	E 2850	E 2550
A4-190	190	245	E 5500	E 4450	E 4000	E 3550	E 3300	E 3100	E 2900	E 2600
A4-195	195	250	E 5500	E 4500	E 4050	E 3600	E 3350	E 3100	E 2900	E 2600

Note - E : End Bar, C : Center Bar, L : S : (79p.)

철 골 조			사용시 트러스테크의 허용 스펠							
A5 - TYPE			<ul style="list-style-type: none"> • : $f_{ck}=210\text{ kgf/cm}^2$ • : $f_y=5,000\text{ kgf/cm}^2$ • : 2.0 cm • : 2.5 cm • TRUSS PITCH : 200 mm • 가 : 100 kgf/m^2 							
L A T T I C E		5,6								
		1-D12								
		2-D7								
S P A N		20.0cm								
		1								
			LIVE LOAD (kgf/m ²)							
TYPE	h (mm)	SLAB THK. (mm)	0.00	300	500	800	1000	1250	1500	2000
A5- 65	65	120	S 4350	C 3350	C 2950	C 2500	C 2300	C 2150	C 2000	C 1750
A5- 70	70	125	S 4500	C 3450	C 3000	C 2600	C 2400	C 2200	C 2050	C 1800
A5- 75	75	130	S 4600	C 3500	C 3050	C 2650	C 2450	C 2250	C 2100	C 1850
A5- 80	80	135	S 4700	C 3550	C 3100	C 2700	C 2500	C 2300	C 2150	C 1900
A5- 85	85	140	S 4800	C 3600	C 3200	C 2750	C 2550	C 2350	C 2200	C 1950
A5- 90	90	145	C 4900	C 3700	C 3250	C 2800	C 2600	C 2400	C 2200	C 2000
A5- 95	95	150	C 4950	C 3750	C 3300	C 2850	C 2650	C 2450	C 2250	C 2000
A5-100	100	155	C 5000	C 3800	C 3350	C 2900	C 2700	C 2450	C 2300	C 2050
A5-105	105	160	C 5050	C 3850	C 3400	C 2950	C 2750	C 2500	C 2350	C 2100
A5-110	110	165	C 5100	C 3900	C 3450	C 3000	C 2750	C 2550	C 2400	C 2150
A5-115	115	170	C 5150	C 3950	C 3500	C 3050	C 2800	C 2600	C 2450	C 2150
A5-120	120	175	C 5150	C 4000	C 3550	C 3100	C 2850	C 2650	C 2450	C 2200
A5-125	125	180	C 5200	C 4050	C 3600	C 3100	C 2900	C 2700	C 2500	C 2250
A5-130	130	185	C 5250	C 4050	C 3600	C 3150	C 2950	C 2700	C 2550	C 2250
A5-135	135	190	C 5250	C 4100	C 3650	C 3200	C 2950	C 2750	C 2550	C 2300
A5-140	140	195	C 5300	C 4150	C 3700	C 3250	C 3000	C 2800	C 2600	C 2350
A5-145	145	200	C 5350	C 4200	C 3750	C 3300	C 3050	C 2800	C 2650	C 2350
A5-150	150	205	C 5350	C 4200	C 3800	C 3300	C 3100	C 2850	C 2650	C 2400
A5-155	155	210	C 5400	C 4250	C 3800	C 3350	C 3100	C 2900	C 2700	C 2400
A5-160	160	215	C 5400	C 4300	C 3850	C 3400	C 3150	C 2900	C 2750	C 2450
A5-165	165	220	C 5450	C 4350	C 3900	C 3400	C 3200	C 2950	C 2750	C 2500
A5-170	170	225	C 5450	C 4350	C 3900	C 3450	C 3200	C 3000	C 2800	C 2500
A5-175	175	230	C 5450	C 4400	C 3950	C 3500	C 3250	C 3000	C 2850	C 2550
A5-180	180	235	C 5500	C 4400	C 4000	C 3500	C 3300	C 3050	C 2850	C 2550
A5-185	185	240	C 5500	C 4450	C 4000	C 3550	C 3300	C 3050	C 2900	C 2600
A5-190	190	245	C 5550	C 4500	C 4050	C 3550	C 3350	C 3100	C 2900	C 2600
A5-195	195	250	C 5550	C 4500	C 4050	C 3600	C 3350	C 3150	C 2950	C 2650

Note - E : End Bar, C : Center Bar, L : S : (79p.)

철 골 조			사용시 트러스데크의 허용 스펠							
A5 - TYPE			<ul style="list-style-type: none"> • : $f_{ck}=210\text{ kgf/cm}^2$ • : $f_y=5,000\text{ kgf/cm}^2$ • : 2.0 cm • : 2.5 cm • TRUSS PITCH : 200 mm • 가 : 100 kgf/m^2 							
L A T T I C E		5,6								
		1-D12								
		2-D7								
S P A N		20.0cm								
		2								
		SLAB THK. (mm)	LIVE LOAD (kgf/m ²)							
TYPE	h (mm)		0.00	300	500	800	1000	1250	1500	2000
A5- 65	65	120	E 5300	E 3850	E 3350	E 2850	E 2650	E 2450	E 2250	E 2000
A5- 70	70	125	E 5350	E 3900	E 3450	E 2950	E 2700	E 2500	E 2300	E 2050
A5- 75	75	130	E 5450	E 4000	E 3500	E 3000	E 2800	E 2550	E 2400	E 2100
A5- 80	80	135	E 5550	E 4100	E 3600	E 3100	E 2850	E 2650	E 2450	E 2200
A5- 85	85	140	E 5600	E 4150	E 3650	E 3150	E 2900	E 2700	E 2500	E 2250
A5- 90	90	145	E 5700	E 4250	E 3750	E 3250	E 3000	E 2750	E 2550	E 2300
A5- 95	95	150	E 5750	E 4300	E 3800	E 3300	E 3050	E 2800	E 2600	E 2350
A5-100	100	155	E 5800	E 4400	E 3900	E 3350	E 3100	E 2850	E 2650	E 2400
A5-105	105	160	E 5900	E 4450	E 3950	E 3400	E 3150	E 2900	E 2750	E 2450
A5-110	110	165	E 5950	E 4550	E 4000	E 3500	E 3250	E 3000	E 2800	E 2500
A5-115	115	170	E 6000	E 4600	E 4050	E 3550	E 3300	E 3050	E 2850	E 2500
A5-120	120	175	E 6050	E 4650	E 4100	E 3600	E 3350	E 3100	E 2850	E 2550
A5-125	125	180	E 6100	E 4700	E 4200	E 3650	E 3400	E 3150	E 2900	E 2600
A5-130	130	185	E 6150	E 4750	E 4250	E 3700	E 3450	E 3150	E 2950	E 2650
A5-135	135	190	E 6150	E 4800	E 4300	E 3750	E 3500	E 3200	E 3000	E 2700
A5-140	140	195	E 6200	E 4850	E 4350	E 3800	E 3550	E 3250	E 3050	E 2750
A5-145	145	200	E 6250	E 4900	E 4400	E 3850	E 3600	E 3300	E 3100	E 2750
A5-150	150	205	E 6300	E 4950	E 4450	E 3900	E 3600	E 3350	E 3150	E 2800
A5-155	155	210	E 6350	E 5000	E 4500	E 3950	E 3650	E 3400	E 3200	E 2850
A5-160	160	215	E 6350	E 5050	E 4550	E 4000	E 3700	E 3450	E 3200	E 2900
A5-165	165	220	E 6400	E 5100	E 4550	E 4000	E 3750	E 3500	E 3250	E 2900
A5-170	170	225	E 6450	E 5150	E 4600	E 4050	E 3800	E 3500	E 3300	E 2950
A5-175	175	230	E 6450	E 5200	E 4650	E 4100	E 3850	E 3550	E 3350	E 3000
A5-180	180	235	E 6500	E 5200	E 4700	E 4150	E 3850	E 3600	E 3350	E 3000
A5-185	185	240	E 6500	E 5250	E 4750	E 4200	E 3900	E 3650	E 3400	E 3050
A5-190	190	245	E 6550	E 5300	E 4800	E 4200	E 3950	E 3650	E 3450	E 3100
A5-195	195	250	E 6550	E 5350	E 4800	E 4250	E 4000	E 3700	E 3450	E 3100

Note - E : End Bar, C : Center Bar, L : S : (79p.)

철 골 조			사용시 트러스테크의 허용 스패							
A6 - TYPE			<ul style="list-style-type: none"> • : $f_{ck}=210\text{ kgf/cm}^2$ • : $f_y=5,000\text{ kgf/cm}^2$ • : 2.0 cm • : 2.5 cm • TRUSS PITCH : 200 mm • 가 : 100 kgf/m^2 							
L A T T I C E		5,6								
		1-D14								
		2-D8								
S P A N		20.0cm								
		1								
			LIVE LOAD (kgf/m ²)							
TYPE	h (mm)	SLAB THK. (mm)	0.00	300	500	800	1000	1250	1500	2000
A6- 65	65	120	S 4450	S 3500	L 3200	C 2850	C 2600	C 2400	C 2250	C 2000
A6- 70	70	125	S 4550	S 3600	S 3300	C 2900	C 2700	C 2450	C 2300	C 2050
A6- 75	75	130	S 4700	S 3700	S 3400	C 3000	C 2750	C 2550	C 2350	C 2100
A6- 80	80	135	S 4800	S 3850	S 3500	C 3050	C 2800	C 2600	C 2400	C 2150
A6- 85	85	140	S 4900	S 3950	C 3600	C 3100	C 2850	C 2650	C 2450	C 2200
A6- 90	90	145	S 5000	S 4050	C 3650	C 3150	C 2950	C 2700	C 2500	C 2250
A6- 95	95	150	S 5100	S 4150	C 3700	C 3200	C 3000	C 2750	C 2550	C 2300
A6-100	100	155	S 5250	S 4250	C 3800	C 3300	C 3050	C 2800	C 2600	C 2300
A6-105	105	160	S 5350	C 4350	C 3850	C 3350	C 3100	C 2850	C 2650	C 2350
A6-110	110	165	S 5450	C 4400	C 3900	C 3400	C 3150	C 2900	C 2700	C 2400
A6-115	115	170	S 5550	C 4450	C 3950	C 3450	C 3200	C 2950	C 2750	C 2450
A6-120	120	175	S 5650	C 4500	C 4000	C 3500	C 3250	C 3000	C 2800	C 2500
A6-125	125	180	S 5750	C 4550	C 4050	C 3550	C 3300	C 3050	C 2850	C 2550
A6-130	130	185	S 5850	C 4600	C 4100	C 3600	C 3350	C 3100	C 2900	C 2550
A6-135	135	190	S 5950	C 4650	C 4150	C 3650	C 3350	C 3100	C 2900	C 2600
A6-140	140	195	C 6000	C 4700	C 4200	C 3650	C 3400	C 3150	C 2950	C 2650
A6-145	145	200	C 6050	C 4750	C 4250	C 3700	C 3450	C 3200	C 3000	C 2700
A6-150	150	205	C 6100	C 4800	C 4300	C 3750	C 3500	C 3250	C 3050	C 2700
A6-155	155	210	C 6100	C 4850	C 4350	C 3800	C 3550	C 3300	C 3050	C 2750
A6-160	160	215	C 6150	C 4900	C 4350	C 3850	C 3600	C 3300	C 3100	C 2800
A6-165	165	220	C 6150	C 4900	C 4400	C 3900	C 3600	C 3350	C 3150	C 2800
A6-170	170	225	C 6200	C 4950	C 4450	C 3900	C 3650	C 3400	C 3150	C 2850
A6-175	175	230	C 6200	C 5000	C 4500	C 3950	C 3700	C 3400	C 3200	C 2900
A6-180	180	235	C 6250	C 5000	C 4500	C 4000	C 3700	C 3450	C 3250	C 2900
A6-185	185	240	C 6250	C 5050	C 4550	C 4050	C 3750	C 3500	C 3250	C 2950
A6-190	190	245	C 6300	C 5100	C 4600	C 4050	C 3800	C 3500	C 3300	C 2950
A6-195	195	250	C 6300	C 5100	C 4650	C 4100	C 3850	C 3550	C 3350	C 3000

Note - E : End Bar, C : Center Bar, L : (79p.)

철 골 조			사용시 트러스데크의 허용 스펠							
A6 - TYPE			<ul style="list-style-type: none"> • : $f_{ck}=210\text{ kgf/cm}^2$ • : $f_y=5,000\text{ kgf/cm}^2$ • : 2.0 cm • : 2.5 cm • TRUSS PITCH : 200 mm • 가 : 100 kgf/m^2 							
L A T T I C E		5,6								
		1-D14								
		2-D8								
		20.0cm								
S P A N		2								
		SLAB THK. (mm)	LIVE LOAD (kgf/m ²)							
TYPE	h (mm)		0.00	300	500	800	1000	1250	1500	2000
A6- 65	65	120	S 5800	E 4350	E 3800	E 3250	E 3000	E 2750	E 2550	E 2250
A6- 70	70	125	S 5950	E 4450	E 3900	E 3350	E 3100	E 2850	E 2650	E 2350
A6- 75	75	130	S 6100	E 4550	E 4000	E 3450	E 3200	E 2900	E 2700	E 2400
A6- 80	80	135	S 6250	E 4650	E 4100	E 3550	E 3250	E 3000	E 2800	E 2500
A6- 85	85	140	S 6350	E 4750	E 4200	E 3600	E 3350	E 3050	E 2850	E 2550
A6- 90	90	145	E 6500	E 4850	E 4250	E 3700	E 3400	E 3150	E 2950	E 2600
A6- 95	95	150	E 6600	E 4950	E 4350	E 3750	E 3500	E 3200	E 3000	E 2650
A6-100	100	155	E 6650	E 5050	E 4450	E 3850	E 3550	E 3300	E 3050	E 2750
A6-105	105	160	E 6750	E 5100	E 4500	E 3900	E 3650	E 3350	E 3100	E 2800
A6-110	110	165	E 6800	E 5200	E 4600	E 4000	E 3700	E 3400	E 3200	E 2850
A6-115	115	170	E 6850	E 5250	E 4650	E 4050	E 3750	E 3450	E 3250	E 2900
A6-120	120	175	E 6950	E 5350	E 4750	E 4100	E 3850	E 3550	E 3300	E 2950
A6-125	125	180	E 7000	E 5400	E 4800	E 4200	E 3900	E 3600	E 3350	E 3000
A6-130	130	185	E 7050	E 5450	E 4850	E 4250	E 3950	E 3650	E 3400	E 3050
A6-135	135	190	E 7100	E 5550	E 4950	E 4300	E 4000	E 3700	E 3450	E 3100
A6-140	140	195	E 7150	E 5600	E 5000	E 4350	E 4050	E 3750	E 3500	E 3150
A6-145	145	200	E 7200	E 5650	E 5050	E 4400	E 4100	E 3800	E 3550	E 3200
A6-150	150	205	E 7250	E 5700	E 5100	E 4500	E 4150	E 3850	E 3600	E 3250
A6-155	155	210	E 7300	E 5750	E 5150	E 4550	E 4200	E 3900	E 3650	E 3300
A6-160	160	215	E 7350	E 5800	E 5200	E 4600	E 4250	E 3950	E 3700	E 3300
A6-165	165	220	E 7350	E 5900	E 5250	E 4650	E 4300	E 4000	E 3750	E 3350
A6-170	170	225	E 7400	E 5950	E 5300	E 4700	E 4350	E 4050	E 3800	E 3400
A6-175	175	230	E 7450	E 6000	E 5350	E 4750	E 4400	E 4100	E 3850	E 3450
A6-180	180	235	E 7500	E 6000	E 5400	E 4800	E 4450	E 4150	E 3900	E 3500
A6-185	185	240	E 7500	E 6050	E 5450	E 4850	E 4500	E 4200	E 3950	E 3500
A6-190	190	245	E 7550	E 6100	E 5500	E 4850	E 4550	E 4250	E 3950	E 3550
A6-195	195	250	E 7600	E 6150	E 5550	E 4900	E 4600	E 4250	E 4000	E 3600

Note - E : End Bar, C : Center Bar, L : S : (79p.)

❖ 시공시 최대 허용 스패ن 일람표의 NOTE

- ◆ D 3000 : 3.0m N.G
- ◆ C 3000 : 3.0m N.G
- ◆ T 3000 : 3.0m N.G
- ◆ L 3000 : 3.0m N.G

❖ 사용시 최대 허용 스패น 일람표의 NOTE

- ◆ C 3000 : 3.0m N.G
- ◆ E 3000 : 3.0m N.G
- ◆ L 3000 : 3.0m N.G
- ◆ S 3000 : 3.0m N.G

3. 트러스데크를 사용한 슬래브 설계 예
 가. 철골조의 설계 예 (L=2.8m)

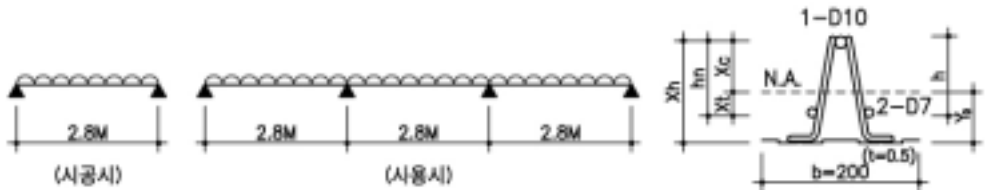

(1) 구조 재료의 규격 및 기준 강도

▪	$f_{ck} = 210 \text{ kgf/cm}^2$
▪	$f_y = 5,000 \text{ kgf/cm}^2$
▪	
▪	200 mm
▪	
▪	130 mm
▪	: 2 cm, : 2.5 cm (가)
▪	A1-75 (t=0.5 mm)

(2) 설계 하중

Ⓐ 시공시 설계 하중

		(kgf/m ²)	(kgf/m ²)
	(t=130)	299.00	299.00
		25.00	25.00
		$299 \times 0.25 = 74.75$	0.00
		150.00	100.00
		548.75	424.00

50% 25%

㉔ 건물 사용시 설계 하중 (단위 : kgf/m^2)

	(t = 1 3 0)	299.0
		25.0
	,	100.0
		350.0
		774.0

100 kgf/m^2

(3) 슬래브 설계

㉑ 시공시의 단면 산정

① 트러스데크 (A1-75 삼각 트러스형)의 역학적 성능

TRUSS TYPE(h) =

$$h = 130 - 20 - 10 - 25 = 75 \text{ 가}$$

▪ : $b = 20 \text{ cm}$

▪ (D10) :

$$a_1 = 0.78 \text{ cm}^2, \quad D_1 = 1.0 \text{ cm}$$

▪ (D7) :

$$a_2 = 0.385 \times 2 = 0.77 \text{ cm}^2, \quad D_2 = 0.7 \text{ cm}$$

▪ DECK PLATE

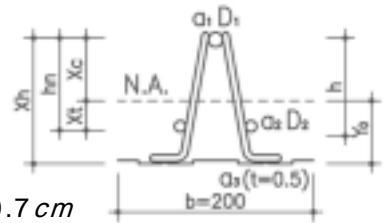

㉒ 중립축 위치 산정

$$Y_0 = \frac{a_1 \times X_h + a_2 \times \left(\frac{D_2}{2} + B.C \right)}{a_1 + a_2}$$

$$= \frac{(0.785 \times 9.5) + (0.77 \times 2.85)}{0.785 + 0.77} = 6.21 \text{ cm}$$

$$X_c = X_h - Y_0 = 9.5 - 6.21 = 3.29 \text{ cm}$$

$$X_i = h_n - X_c = 6.65 - 3.29 = 3.36 \text{ cm}$$

$$X_h = h + B.C - \frac{D_1}{2} = 7.5 + 2.5 - \frac{1.0}{2} = 9.5 \text{ cm}$$

B.C : BOTTOM COVER

㉞ 단면 2차 모멘트

$$\begin{aligned}
 I_0 &= \left[\frac{D_1^4}{64} + a_1 \times X_c^2 + \frac{D_2^4}{64} \times 2 + a_2 \times X_t^2 \right] \times \frac{100}{b_1} \\
 &= \left[\frac{1.0^4}{64} + 0.785 \times 3.29^2 \right. \\
 &\quad \left. + \frac{0.7^4}{64} \times 2 + 0.77 \times 3.36^2 \right] \times \frac{100}{20} \\
 &= 86.33 \text{ cm}^4 / \text{m}
 \end{aligned}$$

㉟ 단면 계수

$$Z_c = \frac{I_0}{X_c} = \frac{86.33}{3.29} = 26.24 \text{ cm}^3$$

$$Z_t = \frac{I_0}{X_t} = \frac{86.33}{3.36} = 25.69 \text{ cm}^3$$

㊱ 상부 철선의 압축 강도(장기)

: D10 , $a_1 = 0.785 \text{ cm}^2$

2 : $I_0 = \frac{D^4}{64} = \frac{1.0^4}{64} = 0.049 \text{ cm}^4$

2 : $i = \sqrt{\frac{I_0}{a_1}} = \sqrt{\frac{0.049}{0.785}} = 0.250 \text{ cm}$

() : $l_1 = 20 \text{ cm}$

: $\frac{l_1}{i} = \frac{20}{0.250} = 80.00$

: $\rho = \sqrt{\frac{2E}{0.6f_y}} = \sqrt{\frac{2 \times 2100}{0.6 \times 5.0}} = 83.12$

: ρ

$$\begin{aligned}
 {}_s f_c &= \left[1 - 0.4 \left(\frac{80.00}{\rho} \right)^2 \right] \cdot \frac{f_y}{n} \\
 &= \left[1 - 0.4 \left(\frac{80.00}{83.12} \right)^2 \right] \cdot \frac{5.0}{2.12} = 1.486 \text{ tf/cm}^2
 \end{aligned}$$

$$n = \frac{3}{2} + \frac{2}{3} \left(\frac{80.00}{\rho} \right)^2 = \frac{3}{2} + \frac{2}{3} \left(\frac{80.00}{83.12} \right)^2 = 2.12$$

③ 래티스재의 압축 강도

$$: 5 \quad , \quad a_1 = 0.20 \text{ cm}^2$$

$$2 \quad : \quad I_o = \frac{D^4}{64} = \frac{0.5^4}{64} = 0.0031 \text{ cm}^4$$

$$2 \quad : \quad i = \sqrt{\frac{I_o}{a_1}} = \sqrt{\frac{0.0031}{0.20}} = 0.13 \text{ cm}$$

$$: \quad I_2 = \sqrt{\left(\frac{I_1}{2}\right) + h_n^2} = \sqrt{10.0^2 + 6.65^2} = 12.01 \text{ cm}$$

$$: \quad \lambda = \frac{I_2}{i} = \frac{12.01}{0.13} = 92.38$$

$$\rho = \sqrt{\frac{2E}{0.6f_y}} = \sqrt{\frac{2 \times 2100}{0.6 \times 5.0}} = 83.12$$

> ρ

$$s f_c = \frac{0.277 f_y}{\left(\frac{\lambda}{\rho}\right)^2} = \frac{0.277 \times 5.0}{\left(\frac{92.38}{83.12}\right)^2} = 1.12 \text{ tf/cm}^2$$

$$= \tan^{-1}\left(\frac{h_n}{\frac{1}{2}}\right) = \tan^{-1}(0.665) = 33.6^\circ$$

(4) 시공시 처짐 검토 (ONE-SPAN)

$$I_x = 2.8 - 0.2 + 0.13 (\text{지점이 동거리}) = 2.73 \text{ m} < 2.8 \text{ m} \quad 3.4.5 \quad (1)$$

$$W = 0.424 \text{ tf/m}^2$$

$$= \frac{5 W I_x^4}{384 E I_o} = \frac{5 \times 0.424 \div 100 \times 273^4}{384 \times 2100 \times 86.33} = 1.69 \text{ cm} > 1.0 \text{ cm} \quad N.G$$

Camber : L / 250

$$a_{act} = c = 1.69 - \frac{273}{250} = 0.60 < 1.0 \text{ cm} \quad O.K$$

() (a_{act}) SPAN 1.0 cm

(5) 시공시 트러스데크의 응력 검토 (단순 지지 ONE-SPAN)

$$l_x = 2.8 - 0.2 + 0.13 = 2.73 \text{ m} \quad 3.4.5 \quad (1)$$

$$W = 0.2 \times 0.549 = 0.110 \text{ tf/m}$$

$$M = \frac{W \cdot l_x^2}{8} = \frac{0.110 \times 2.73^2}{8} = 0.103 \text{ tf} \cdot \text{m}$$

$$V = \frac{W \cdot l_x}{2} = \frac{0.110 \times 2.73}{2} = 0.15 \text{ tf}$$

Ⓐ 상부 철선

$$\frac{c}{s f_c} = \frac{100 \cdot M}{Z_c \cdot s f_c \cdot 1.5} = \frac{0.103 \times 100}{\frac{26.24}{5} \times 1.486 \times 1.5} = 0.88 < 1.0 \quad O.K$$

$$Z_c / 5 \quad 1$$

Ⓑ 하부 철선

$$\frac{t}{s f_t} = \frac{100 \cdot M}{Z_t \cdot s f_t \cdot 1.5} = \frac{0.103 \times 100}{\left(\frac{25.69}{5}\right) \times 2.2 \times 1.5} = 0.61 < 1.0 \quad O.K$$

Ⓒ 래티스재

$$N_c = \frac{V}{\sin} = \frac{0.15}{\sin 33.6} = 0.27 \text{ tf}$$

$$c = \frac{0.5 \times N_c}{a_c} = \frac{0.5 \times 0.27}{0.196} = 0.69 \text{ tf/cm}^2$$

$$\frac{c}{s f_c \times 1.5} = \frac{0.69}{1.12 \times 1.5} = 0.41 < 1.0 \quad O.K$$

(6) 건물 사용시의 단면 산정

Ⓐ 건물 사용시 하중 조합

$$\begin{aligned} W_u &= 1.4 \times \text{고정하중} + 1.7 \times \text{활하중} \\ &= 1.4 \times 0.424 + 1.7 \times 0.35 = 1.19 \text{ tf/m}^2 \end{aligned}$$

$$\begin{aligned} W_1 &= 1.4 \times \text{추가하중} + 1.7 \times \text{활하중} \\ &= 1.4 \times 0.10 + 1.7 \times 0.35 = 0.735 \text{ tf/m}^2 \end{aligned}$$

$$\begin{aligned}
 W_2 &= 1.4 \times (\text{고정 하중} - \text{추가 하중}) \\
 &= 1.4 \times (0.424 - 0.10) = 0.454 \text{ tf/m}^2
 \end{aligned}$$

㉔ 실용 해법에 의한 휨모멘트 산정 (3-SPAN 연속)

3.4.5 (1)



MAX. NEG. MOMENT()

$$M_{x1} = \frac{W_u \times x^2}{10} = \frac{1.19 \times 2.73^2}{10} = 0.887 \text{ tf} \cdot \text{m} \quad 3.4.1 \quad (4) \quad (\text{가})$$

MAX. POS. MOMENT()

$$M_{x2} = \frac{W_1 \times x^2}{11} = \frac{0.735 \times 2.73^2}{11} = 0.498 \text{ tf} \cdot \text{m} \quad 3.4.1 \quad (4) \quad (\text{가})$$

$$M_{x3} = \frac{W_2 \times x^2}{8} = \frac{0.454 \times 2.73^2}{8} = 0.423 \text{ tf} \cdot \text{m}$$

(7) 사용시 하중에 의한 처짐 검토

❖ 가 1

$$h = \frac{L_x}{24} = \frac{273}{24} = 11.38 < 13 \text{ cm}$$

- 4.3.1 1 (1)

(8) 트러스데크(A1-75) 주근 검토

㉑ 상부 철선

$$D10, a_1 = 0.785 \text{ cm}^2, f_y = 5000 \text{ kgf/cm}^2, f'_{ck} = 210 \text{ kg/cm}^2, d = 9.50 \text{ cm}$$

$$R_u = \frac{M_{x1} \times 10^5}{100 \times d^2} = \frac{0.887 \times 10^5}{100 \times 9.50^2} = 9.83 \text{ kgf/cm}^2$$

$$R_n = \frac{R_u}{0.9} = 10.92 \text{ kgf/cm}^2$$

$$= \frac{0.85 f_{ck}}{f_y} \times \left(1 - \sqrt{1 - \frac{2R_n}{0.85 f_{ck}}} \right)$$

$$= \frac{0.85 \times 210}{5000} \times \left(1 - \sqrt{1 - \frac{2 \times 10.92}{0.85 \times 210}} \right) = 0.0023$$

$$A_s = \rho \times 100 \times d = 0.0023 \times 100 \times 9.5 = 2.19 \text{ cm}^2$$

$$A_{s,\min} = \frac{14}{f_y \cdot b_w d} = \frac{14}{5000 \times 100 \times 9.5} = 2.66 \text{ cm}^2 \quad (6.3.2)$$

$$s = \frac{a_c \times 100}{A_s} = \frac{0.785 \times 100}{2.66} = 29.51 \text{ cm} > 20 \text{ cm} \quad O.K$$

㉔ 하부 철선

$$2 - D7, a_2 = 0.77 \text{ cm}^2, f_y = 5000 \text{ kgf/cm}^2$$

$$f_{ck} = 210 \text{ kgf/cm}^2, d = 10.15 \text{ cm}$$

$$R_u = \frac{(M_{x2} + M_{x3}) \times 10^5}{100 \times d^2} = \frac{(0.498 + 0.423) \times 10^5}{100 \times 10.15^2} = 8.94 \text{ kgf/cm}^2$$

$$R_n = \frac{R_u}{0.9} = 9.93 \text{ kgf/cm}^2$$

$$= \frac{0.85 f'_c}{f_y} \times \left(1 - \sqrt{1 - \frac{2R_n}{0.85 f'_c}} \right)$$

$$= \frac{0.85 \times 210}{5000} \times \left(1 - \sqrt{1 - \frac{2 \times 9.93}{0.85 \times 210}} \right) = 0.00204$$

$$A_s = \rho \times 100 \times d = 0.00236 \times 100 \times 10.15 = 2.40 \text{ cm}^2$$

$$A_{s,\min} = \frac{14}{f_y \cdot b_w d} = \frac{14}{5000 \times 100 \times 10.15} = 2.84 \text{ cm}^2 > 2.40 \text{ cm}^2$$

(6.3.2)

$$s = \frac{a_t \times 100}{A_s} = \frac{0.77 \times 100}{2.84} = 27.11 \text{ cm} > 20 \text{ cm} \quad O.K$$

© 수축 · 온도 철근

$$A_{s,\min} = 0.0020 \times 100 \times D = 0.0020 \times 100 \times 13 = 2.60 \text{ cm}^2/m \quad 5.7.2(1)$$

$$f_y = 4,000 \text{ kgf/cm}^2$$

$$s = \frac{a_t \times 100}{A_s} = \frac{0.71 \times 100}{2.60} = 27.31 \text{ cm}$$

D10 @ 250 ()

④ 정착 및 이음 길이 산정 (일반식)

:

$$l_d = \frac{0.285 \cdot d_b \cdot f_y}{\sqrt{f_{ck}}} \cdot \frac{c + K_{tr}}{d_b} = 25.17 \text{ cm} \quad 30 \text{ cm}$$

$$(B \quad) = 1.3 \times l_d = 1.3 \times 30.00 = 39.00 \text{ cm}$$

나. 철근 콘크리트조의 설계 예 (L=3.3m)

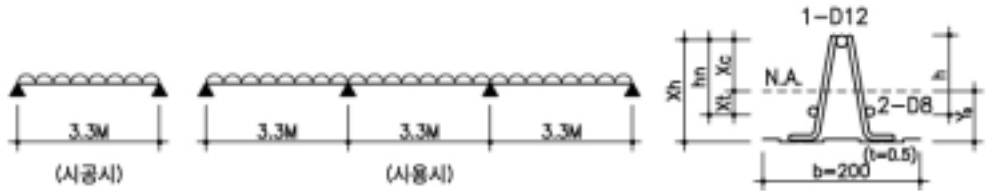

(1) 구조 재료의 규격 및 기준 강도

▪	$f_{ck} = 210 \text{ kgf/cm}^2$
▪	$f_y = 5,000 \text{ kgf/cm}^2$
▪	
▪	
▪	30 cm
▪	13.0 cm
▪	: 2 cm : 2.5 cm
▪	A2-75

(2) 설계 하중

㉠ 시공시 설계 하중

		(kgf/m ²)	(kgf/m ²)
	(t=130)	299.0	299.0
		25.0	25.0
		299 × 0.5=149.5	0.0
		150.0	100.0
		623.5	424.0

25%

50%

㉔ 건물 사용시 설계 하중 (단위 : kgf/m^2)

	(t = 1 3 5)	299.0
		25.0
		100.0
		350.0
		774.0

100 kgf/m^2

(3) 슬래브 설계

㉑ 시공시의 단면 산정

① 트러스데크(A2-75 삼각 트러스형)의 역학적 성능

◆ : $b = 20\text{ cm}$

◆ (D12) :

$$a_1 = 1.131\text{ cm}^2, \quad D_1 = 1.2\text{ cm}$$

◆ (D8) :

$$a_2 = 0.503 \times 2 = 1.006\text{ cm}^2,$$

$$D_2 = 0.8\text{ cm}$$

◆ Deck plate

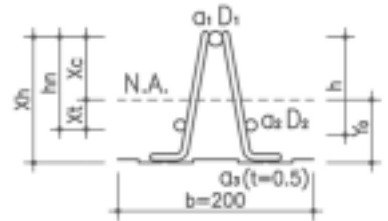

㉒ 중립축 위치 산정 :

$$Y_0 = \frac{a_1 \times X_h + a_2 \times \left(\frac{D_2}{2} + B.C \right)}{a_1 + a_2}$$

$$= \frac{(1.131 \times 9.4) + (1.006 \times 2.9)}{1.131 + 1.006} = 6.34\text{ cm}$$

$$X_c = X_h - Y_0 = 9.4 - 6.34 = 3.06\text{ cm}$$

$$X_t = h_n - X_c = 6.5 - 3.06 = 3.44\text{ cm}$$

$$X_h = h + B.C - \frac{D_1}{2} = 7.5 + 2.5 - \frac{1.2}{2} = 9.4\text{ cm}$$

B.C : BOTTOM COVER

㉞ 단면2차 모멘트

$$\begin{aligned}
 I_0 &= \left[\frac{D_1^4}{64} + a_1 \times X_c^2 + \frac{D_2^4}{64} \times 2 + a_2 \times X_t^2 \right] \times \frac{100}{b_1} \\
 &= \left[\frac{1.2^4}{64} + 1.131 \times 3.06^2 + \frac{0.8^4}{64} \times 2 + 1.006 \times 3.44^2 \right] \times \frac{100}{20} \\
 &= 22.64 \times \frac{100}{20} = 113.18 \text{ cm}^4/\text{m}
 \end{aligned}$$

㉟ 단면계수 :

$$Z_c = \frac{I_0}{X_c} = \frac{113.18}{3.06} = 36.99 \text{ cm}^3$$

$$Z_t = \frac{I_0}{X_t} = \frac{113.18}{3.44} = 32.90 \text{ cm}^3$$

㊱ 상부 철선의 압축 강도 (장기)

: D12 , $a_1 = 1.131 \text{ cm}^2$

2 : $I_0 = \frac{D^4}{64} = \frac{1.2^4}{64} = 0.102 \text{ cm}^4$

2 : $i = \sqrt{\frac{I_0}{a_1}} = \sqrt{\frac{0.102}{1.131}} = 0.300 \text{ cm}$

() : $l_1 = 20 \text{ cm}$

: $= \frac{l_1}{i} = \frac{20}{0.300} = 66.67$

: $\rho = \sqrt{\frac{2E}{0.6 f_y}} = \sqrt{\frac{2 \times 2100}{0.6 \times 5.0}} = 83.12$

: ρ

$$\begin{aligned}
 s f_c &= \left[1 - 0.4 \left(\frac{66.67}{\rho} \right)^2 \right] \cdot \frac{f_y}{n} = \left[1 - 0.4 \left(\frac{66.67}{83.12} \right)^2 \right] \times \frac{5.0}{1.93} \\
 &= 1.924 \text{ tf/cm}^2
 \end{aligned}$$

$$n = \frac{3}{2} + \frac{2}{3} \left(\frac{66.67}{\rho} \right)^2 = \frac{3}{2} + \frac{2}{3} \left(\frac{66.67}{83.12} \right)^2 = 1.93$$

③ 래티스재의 압축 강도

$$\begin{aligned}
 & : 5 \quad , \quad a_1 = 0.196 \text{ cm}^2 \\
 2 & : \quad I_o = \frac{D^4}{64} = \frac{\times (0.5^4)}{64} = 0.0031 \text{ cm}^4 \\
 2 & : \quad i = \sqrt{\frac{I_o}{a_1}} = \sqrt{\frac{0.0031}{0.196}} = 0.13 \text{ cm} \\
 & : \quad I_2 = \sqrt{\left(\frac{I_1}{2}\right)^2 + h_n^2} = \sqrt{10.0^2 + 6.50^2} = 11.93 \text{ cm} \\
 & : \quad = \frac{I_2}{i} = \frac{11.93}{0.13} = 91.75 \\
 & : \quad \rho = \sqrt{\frac{^2 E}{0.6 f_y}} = \sqrt{\frac{^2 \times 2100}{0.6 \times 5.0}} = 83.12 \\
 & : \quad > \rho \\
 s f_c & = \frac{0.277 f_y}{\left(\frac{\quad}{\rho}\right)^2} = \frac{0.277 \times 5.0}{\left(\frac{91.75}{83.12}\right)^2} = 1.14 \text{ tfl/cm}^2 \\
 & : \\
 & = \tan^{-1}\left(\frac{h_n}{\left(\frac{I_1}{2}\right)}\right) = \tan^{-1}(0.65) = 33.02^\circ
 \end{aligned}$$

㉞ 시공시 처짐 검토 (ONE-SPAN)

$$l_x = 3.3 - 0.3(\text{보폭}) + 0.13(\text{지점이동거리}) = 3.13 \text{ m}$$

$$W = 0.424 \text{ tfl/m}^2$$

$$= \frac{5 W l_x^4}{384 E I_o} = \frac{5 \times 0.424 / 100 \times 313^4}{384 \times 2100 \times 113.18} = 2.23 \text{ cm} > 1.0 \text{ cm } N.G$$

$$(\quad) \quad (\text{act}) \quad \text{SPAN} \quad 1.0 \text{ cm}$$

$$\text{Camber} : L/200$$

$$s_{act} = -c = 2.23 - \frac{313}{200} = 2.23 - 1.57 = 0.67 \text{ cm} < 1.0 \text{ cm } O.K$$

© 시공시 철선의 응력 검토 (단순 지지 ONE-SPAN)

$$l_x = 3.3 - 0.3 + \frac{0.13}{2} = 3.13 \text{ m} \quad \text{3.4.5 (1)}$$

(보폭) (지점이동거리)

$$W = 0.2 \times 0.624 = 0.125 \text{ tf/m}$$

$$M = \frac{W \cdot l_x^2}{8} = \frac{0.125 \times 3.13^2}{8} = 0.153 \text{ tf} \cdot \text{m}$$

$$V = \frac{W \cdot l_x}{2} = \frac{0.125 \times 3.13}{2} = 0.196 \text{ tf}$$

① 상부 철선

$$\frac{c}{s f_c} = \frac{100 \cdot M}{Z_c \cdot s f_c \cdot 1.5} = \frac{100 \times 0.153}{\left(\frac{36.99}{5}\right) \times 1.924 \times 1.5} = 0.72 < 1.0 \quad O.K$$

$$Z_c / 5 \quad 1$$

② 하부 철선

$$\frac{t}{s f_t} = \frac{100 \cdot M}{Z_t \cdot s f_t \cdot 1.5} = \frac{100 \times 0.153}{\left(\frac{32.9}{5}\right) \times 2.2 \times 1.5} = 0.71 < 1.0 \quad O.K$$

③ 래티스재

$$N_c = \frac{V}{\sin} = \frac{0.196}{\sin 33.02^\circ} = 0.36 \text{ tf}$$

$$c = \frac{0.5 \times N_c}{a_c} = \frac{0.5 \times 0.36}{0.196} = 0.92 \text{ tf/cm}^2$$

$$\frac{c}{s f_c \times 1.5} = \frac{0.92}{1.14 \times 1.5} = 0.54 < 1.0 \quad O.K$$

(4) 건물 사용시의 단면 산정

㉠ 건물 사용시 하중 조합

$$W_u = 1.4 \times \text{고정하중} + 1.7 \times \text{활하중} \\ = 1.4 \times 0.424 + 1.7 \times 0.35 = 1.189 \text{ tf/m}^2$$

$$W_1 = 1.4 \times \text{추가하중} + 1.7 \times \text{활하중} \\ = 1.4 \times 0.10 + 1.7 \times 0.35 = 0.735 \text{ tf/m}^2$$

$$W_2 = 1.4 \times (\text{고정하중} - \text{추가하중}) \\ = 1.4 \times (0.424 - 0.10) = 0.454 \text{ tf/m}^2$$

㉡ 휨 모멘트 산정 (3-SPAN 연속)

$$l_x = 3.3 - 0.30 (\text{보폭}) = 3.0 \text{ m} \quad 3.4.5 \quad (2)$$

MAX. NEG. MOMENT()

$$M_{x1} = \frac{W_u \cdot l_x^2}{10} = \frac{1.189 \times 3.0^2}{10} = 1.07 \text{ tf} \cdot \text{m} \quad 3.4.1 \quad (4) \quad (\text{가})$$

MAX. POS. MOMENT()

$$M_{x2} = \frac{W_1 \cdot l_x^2}{14} = \frac{0.735 \times 3.0^2}{14} = 0.473 \text{ tf} \cdot \text{m} \quad 3.4.1 \quad (4) \quad (\text{가})$$

가

$$M_{x3} = \frac{W_2 \cdot l_x^2}{8} = \frac{0.454 \times 3.0^2}{8} = 0.510 \text{ tf} \cdot \text{m}$$

㉢ 사용시 하중에 의한 처짐 검토

가

1

$$h = \frac{L_x}{24} = \frac{300}{24} = 12.5 < 13 \text{ cm}$$

4.3.1 1 (1)

⑩ 트러스데크(A2-75) 주근 검토

① 상부 철선

$$D12, a_1 = 1.131 \text{ cm}^2, f_y = 5000 \text{ kgf/cm}^2$$

$$f_{ck} = 210 \text{ kgf/cm}^2, d = 9.40 \text{ cm}$$

$$R_u = \frac{M_{x1} \times 10^5}{100 \times d^2} = \frac{1.07 \times 10^5}{100 \times 9.40^2} = 12.11 \text{ kgf/cm}^2$$

$$R_n = \frac{R_u}{0.9} = 13.46 \text{ kgf/cm}^2$$

$$= \frac{0.85 f'_c}{f_y} \times \left(1 - \sqrt{1 - \frac{2R_n}{0.85 f'_c}} \right)$$

$$= \frac{0.85 \times 210}{5000} \times \left(1 - \sqrt{1 - \frac{2 \times 13.46}{0.85 \times 210}} \right) = 0.0028$$

$$A_s = \rho \times 100 \times d = 0.0028 \times 100 \times 9.4 = 2.63 \text{ cm}^2$$

$$A_{s, \min} = \frac{14}{f_y b_w d} = \frac{14}{5000 \times 100 \times 9.4} = 2.63 \text{ cm}^2 \quad (6.3.2)$$

$$s = \frac{a_c \times 100}{A_s} = \frac{1.131 \times 100}{2.63} = 43.0 \text{ cm} \quad 20 \text{ cm} \quad \text{O.K}$$

② 하부 철선

$$2 - D8, a_2 = 1.006 \text{ cm}^2, f_y = 5000 \text{ kgf/cm}^2$$

$$f'_c = 210 \text{ kgf/cm}^2, d = 10.1 \text{ cm}$$

$$R_u = \frac{(M_{x2} + M_{x3}) \times 10^5}{100 \times d^2} = \frac{(0.473 + 0.510) \times 10^5}{100 \times 10.1^2} = 9.64 \text{ kgf/cm}^2$$

$$R_n = \frac{R_u}{0.9} = 10.7 \text{ kgf/cm}^2$$

$$= \frac{0.85 f_{ck}}{f_y} \times \left(1 - \sqrt{1 - \frac{2R_n}{0.85 f_{ck}}} \right)$$

$$= \frac{0.85 \times 210}{5000} \times \left(1 - \sqrt{1 - \frac{2 \times 10.7}{0.85 \times 210}} \right) = 0.00221$$

$$A_s = \rho \times 100 \times d = 0.00221 \times 100 \times 10.10 = 2.23 \text{ cm}^2$$

$$A_{s,\min} = \frac{14}{f_y b_w d} = \frac{14}{5000 \times 100 \times 10.1} = 2.83 > 2.23 \text{ cm}^2 \quad (6.3.2)$$

$$s = \frac{a_t \times 100}{A_s} = \frac{1.006 \times 100}{2.83} = 35.55 \text{ cm} > 20 \text{ cm} \quad O.K$$

③ 수축 · 온도 철근

$$A_{s,\min} = 0.0020 \times 100 \times D = 0.0020 \times 100 \times 13 = 2.60 \text{ cm}^2/m \quad 5.7.2(1)$$

$$f_y = 4000 \text{ kgf/cm}^2$$

$$s = \frac{a_t \times 100}{A_s} = \frac{0.71 \times 100}{2.60} = 27.31 \text{ cm}$$

D10 @ 250 ()

④ 정착 및 이음 길이 산정 (일반식)

:

$$l_d = \frac{0.285 \cdot d_b \cdot f_y}{\sqrt{f_{ck}}} \cdot \left(\frac{c + K_{tr}}{d_b} \right) = 30.21 \text{ cm} \quad 30 \text{ cm}$$

$$(B) = 1.3 \times l_d = 1.3 \times 30.21 = 39.27 \text{ cm}$$

다. 시공시 SUPPORT를 설치하는 경우 (L=4.7m)

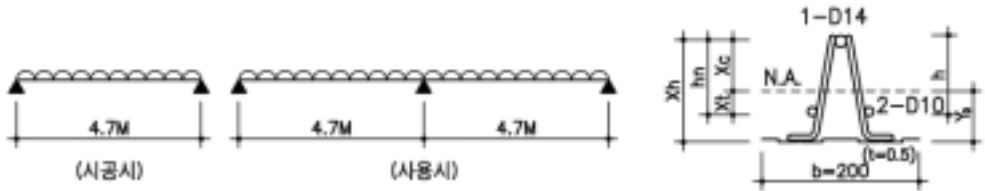

(1) 구조 재료의 규격 및 기준 강도

▪	$f_{ck} = 210 \text{ kgf/cm}^2$
▪	$f_y = 5,000 \text{ kgf/cm}^2$
▪	
▪	
▪	30 cm
▪	13.5 cm
▪	: 2 cm : 2.5 cm (가)
▪	A3-75 (t=0.5 mm)

(2) 설계 하중

Ⓐ 시공시 설계 하중

		(kgf/m ²)	(kgf/m ²)
	(t=130)	310.0	310.0
		25.0	25.0
		310 × 0.5=155.0	0.0
		150.0	100.0
		640.0	435.0

25%

50%

㉔ 건물 사용시 설계 하중 (단위 : kgf/m^2)

	(t = 1 3 5)	310.0
		25.0
		100.0
		350.0
		785.0

100 kgf/m^2

(3) 슬래브 설계

㉑ 시공시의 단면 산정

① 트러스데크(A3-80 삼각 트러스형)의 역학적 성능

◆ : $b = 20 \text{ cm}$

◆ :

(D14) : $a_1 = 1.539 \text{ cm}^2$, $D_1 = 1.4 \text{ cm}$

(D10) :

$a_2 = 0.785 \times 2 = 1.57 \text{ cm}^2$, $D_2 = 1.0 \text{ cm}$

◆ :

(D10) :

$a_2 = 0.785 \times 2 = 1.57 \text{ cm}^2$, $D_2 = 1.0 \text{ cm}$

(D14) :

$a_1 = 1.539 \text{ cm}^2$
 $D_1 = 1.4 \text{ cm}$

◆ DECK PLATE

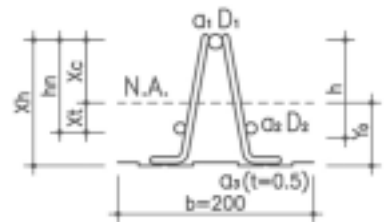

㉒ 중립축 위치산정 :

$$Y_0 = \frac{a_1 \cdot X_h + a_2 \cdot \left(\frac{D_2}{2} + B.C \right)}{a_1 + a_2}$$

$$= \frac{(1.539 \times 9.3) + (0.785 \times 2 \times 3.0)}{1.539 + 1.57} = 6.37 \text{ cm}$$

$$X_c = X_h - Y_0 = 9.8 - 6.37 = 3.43 \text{ cm}$$

$$X_t = h_n - X_c = 6.8 - 3.43 = 3.37 \text{ cm}$$

$$X_h = h + B.C - \frac{D_1}{2} = 7.5 + 2.5 - \frac{1.4}{2} = 9.8 \text{ cm}$$

B.C : BOTTOM COVER

㉞ 단면 2차 모멘트 :

$$\begin{aligned} I_0 &= \left[\frac{D_1^4}{64} + a_1 \cdot X_c^2 + \frac{D_2^4}{64} \times 2 + a_2 \cdot X_t^2 \right] \times \frac{100}{b_1} \\ &= \left[\frac{\times 1.4^4}{64} + 1.539 \times 3.43^2 + \frac{\times 1.0^4}{64} \times 2 + 2 \times 0.785 \times 3.37^2 \right] \times \frac{100}{20} \\ &= 36.22 \times \frac{100}{20} = 181.11 \text{ cm}^4/\text{m} \end{aligned}$$

㉟ 단면 계수 :

$$Z_c = \frac{I_0}{X_c} = \frac{181.11}{3.43} = 52.80 \text{ cm}^3$$

$$Z_t = \frac{I_0}{X_t} = \frac{181.11}{3.37} = 53.74 \text{ cm}^3$$

㊱ 연속단 하부 철선의 압축 강도 (장기)

$$(D10) : a_2 = 0.785 \text{ cm}^2$$

$$I_o = \frac{\cdot D^4}{64} = \frac{\times 1.0^4}{64} = 0.049 \text{ cm}^4$$

$$i = \sqrt{\frac{I_o}{a_2}} = \sqrt{\frac{0.049}{0.785}} = 0.25 \text{ cm}$$

$$() : l_1 = 20 \text{ cm}$$

$$= \frac{l_1}{i} = \frac{20}{0.25} = 80.0$$

$$\rho = \sqrt{\frac{2 \cdot E}{0.6 f_y}} = \sqrt{\frac{2 \times 2100}{0.6 \times 5.0}} = 83.12$$

$$\begin{aligned}
 & : \quad \rho \\
 s f_c &= \left[1 - 0.4 \left(\frac{\quad}{\rho} \right)^2 \right] \cdot \frac{f_y}{n} \\
 &= \left[1 - 0.4 \left(\frac{80.00}{83.12} \right)^2 \right] \times \frac{5}{2.117} = 1.486 \text{ tfl/cm}^2 \\
 n &= \frac{3}{2} + \frac{2}{3} \left(\frac{\quad}{\rho} \right)^2 = \frac{3}{2} + \frac{2}{3} \left(\frac{80.00}{83.12} \right)^2 = 2.117
 \end{aligned}$$

③ 래티스재의 압축 강도

$$\begin{aligned}
 (5) & : a_1 = 0.196 \text{ cm}^2 \\
 2 & : I_0 = \frac{D^4}{64} = \frac{\quad \times (0.5^4)}{64} = 0.0031 \text{ cm}^4 \\
 2 & : i = \sqrt{\frac{I_0}{a_1}} = \sqrt{\frac{0.0031}{0.196}} = 0.13 \text{ cm} \\
 & : I_2 = \sqrt{\left(\frac{I_1}{2} \right)^2 + h_n^2} = \sqrt{10.0^2 + 6.80^2} = 12.09 \text{ cm} \\
 & : = \frac{I_2}{i} = \frac{12.09}{0.13} = 93.02 \\
 & : \rho = \sqrt{\frac{\quad^2 \cdot E}{0.6 f_y}} = \sqrt{\frac{\quad^2 \times 2100}{0.6 \times 5.0}} = 83.12 \\
 & : \quad > \rho \\
 s f_c &= \frac{0.277 f_y}{\left(\frac{\quad}{\rho} \right)^2} = \frac{0.277 \times 5.0}{\left(\frac{93.02}{83.12} \right)^2} = 1.11 \text{ tfl/cm}^2 \\
 &= \tan^{-1} \left(\frac{h_n}{\left(\frac{\quad}{2} \right)} \right) = \tan^{-1}(0.65) = 32.21^\circ
 \end{aligned}$$

㉔ 시공시 처짐 및 SUPPORT 유·무 검토

SUPPORT

$$l_x = L - \text{보폭} + \text{지점이동거리} = 4.7 - 0.3 + 0.135 = 4.535 \text{ m}$$

3.4.5 (1)

$$W = 0.435 \text{ tf/m}^2$$

$$= \frac{5 W I_x^4}{384 E I_0} = \frac{5 \times 0.435 \div 100 \times 454^4}{384 \times 2100 \times 181.11} = 6.33 \text{ cm} > 1.0 \text{ cm} \quad N.G$$

SUPPORT

$$I_x = \frac{L}{2} - \frac{\text{보폭}}{2} + \text{지점이동거리} = \frac{4.7}{2} - \frac{0.3}{2} + 0.135 = 2.34 \text{ m}$$

3.4.5 (1)

$$= \frac{W I_x^4}{185 E I_0} = \frac{0.435 \div 100 \times 234^4}{185 \times 2100 \times 181.11} = 0.19 \text{ cm} < 1.0 \text{ cm} \quad O.K$$

© 시공시 철선의 응력 검토(SUPPORT 설치시)

$$I_x = \frac{L}{2} - \frac{\text{보폭}}{2} + \text{지점이동거리} = \frac{4.7}{2} - \frac{0.3}{2} + 0.135 = 2.34 \text{ m}$$

$$W = 0.2 \times 0.64 = 0.128 \text{ tf/m}$$

$$M = \frac{W \cdot I_x^2}{8} = \frac{0.128 \times 2.34^2}{8} = 0.088 \text{ tf} \cdot \text{m}$$

$$V = \frac{5 \cdot W \cdot I_x}{8} = \frac{5 \times 0.128 \times 2.34}{8} = 0.187 \text{ tf}$$

■

◆ ()

$$\frac{c}{s f_c} = \frac{100 \cdot M}{Z_c \cdot s f_c \cdot 1.5}$$

$$= \frac{100 \times 0.088}{\left(\frac{53.74}{5}\right) \times 1.486 \times 1.5} = 0.37 < 1.0 \quad O.K$$

◆ ()

$$\frac{t}{s f_t} = \frac{100 \cdot M}{Z_t \cdot s f_t \cdot 1.5}$$

$$= \frac{100 \times 0.088}{\left(\frac{52.8}{5}\right) \times 2.2 \times 1.5} = 0.25 < 1.0 \quad O.K$$

◆

$$N_c = \frac{V}{\sin} = \frac{0.187}{\sin 32.2^\circ} = 0.35 \text{ tf}$$

$$c = \frac{0.5 \times N_c}{a_c} = \frac{0.5 \times 0.35}{0.196} = 0.90 \text{ tf/cm}^2$$

$$\frac{c}{s f_c \times 1.5} = \frac{0.90}{1.11 \times 1.5} = 0.54 < 1.0 \quad \text{OK}$$

(4) 건물 사용시의 단면 산정

㉠ 건물 사용시의 하중 조합

$$\begin{aligned} W_u &= 1.4 \times \text{고정하중} + 1.7 \times \text{활하중} \\ &= 1.4 \times 0.435 + 1.7 \times 0.35 = 1.204 \text{ tf/m}^2 \end{aligned}$$

$$\begin{aligned} W_1 &= 1.4 \times \text{추가하중} + 1.7 \times \text{활하중} \\ &= 1.4 \times 0.10 + 1.7 \times 0.35 = 0.735 \text{ tf/m}^2 \end{aligned}$$

$$\begin{aligned} W_2 &= 1.4 \times (\text{고정하중} - \text{추가하중}) \\ &= 1.4 \times (0.435 - 0.10) = 0.469 \text{ tf/m}^2 \end{aligned}$$

㉡ 휨 모멘트 산정 (TWO SPAN 연속)

$$l_x = 4.70 - 0.30 (\text{보폭}) = 4.40 \text{ m} \quad 3.4.5(2)$$

MAX. NEG. MOMENT()

$$M_{x1} = \frac{W_u \times l_x^2}{10} = \frac{1.204 \times 4.4^2}{10} = 2.33 \text{ tf} \cdot \text{m}$$

3.4.1 (4) (가)

MAX. POS. MOMENT()

$$M_{x2} = \frac{W_1 \times l_x^2}{14} = \frac{0.735 \times 4.4^2}{14} = 1.017 \text{ tf} \cdot \text{m}$$

3.4.1 (4) (가)

가

$$M_{x3} = \frac{W_2 \times l_x^2}{14} = \frac{0.469 \times 4.4^2}{14} = 0.649 \text{ tf} \cdot \text{m}$$

© 사용 하중에 의한 처짐 검토

가 1

$$\frac{L}{24} = \frac{440}{24} = 18.33 \text{ cm} > 13.5 \text{ cm}$$

4.3.1 1 (1)

$$W_D = \text{고정하중} \times 0.2 = 0.435 \times 0.2 = 0.087 \text{ tf/m}$$

$$W_L = \text{적재하중} \times 0.2 = 0.350 \times 0.2 = 0.07 \text{ tf/m}$$

① 모멘트 산정

$$M_D = \frac{W_D \times l_x^2}{14} = \frac{0.087 \times 4.4^2}{14} = 0.120 \text{ tf} \cdot \text{m}$$

$$M_L = \frac{W_L \times l_x^2}{14} = \frac{0.070 \times 4.4^2}{14} = 0.097 \text{ tf} \cdot \text{m}$$

$$M_{D+L} = 0.12 + 0.097 = 0.217 \text{ tf} \cdot \text{m}$$

$$M_{SUS} = M_D + 0.5 \times M_L = 0.12 + 0.5 \times 0.097 = 0.169 \text{ tf} \cdot \text{m}$$

$$M_D = \frac{W_D \times \frac{x}{2}}{10} = \frac{0.087 \times 4.4^2}{10} = 0.169 \text{ tf} \cdot \text{m}$$

$$M_L = \frac{W_L \times \frac{x}{2}}{10} = \frac{0.070 \times 4.4^2}{10} = 0.136 \text{ tf} \cdot \text{m}$$

$$M_{D+L} = 0.169 + 0.136 = 0.305 \text{ tf} \cdot \text{m}$$

$$M_{SUS} = M_D + 0.5 \times M_L = 0.169 + 0.5 \times 0.136 = 0.237 \text{ tf} \cdot \text{m}$$

② 재료 성질 계수의 산정

$$f_r = 2.0 \sqrt{f_{ck}} = 2.0 \sqrt{210} = 28.98 \text{ kgf/cm}^2$$

$$E_c = 15000\sqrt{f_{ck}} = 15000\sqrt{210} = 2.174 \times 10^5 \text{ kgfl cm}^2$$

$$n = \frac{E_s}{E_c} = \frac{2.1 \times 10^6}{2.174 \times 10^5} = 9.66$$

③ 단면2차 모멘트 산정

㉠ 정 모멘트 단면 산정

$$d = 13.5 - B.C - \frac{D_2}{2} = 13.5 - 2.5 - 0.5 = 10.5 \text{ cm}$$

$$d = T.C + 1.0 + \frac{D_1}{2} = 2.0 + 1.0 + 0.70 = 3.70 \text{ cm}$$

$$B = \frac{b}{nA_s} = \frac{20}{9.66 \times 2 \times 0.785} = 1.319 \text{ cm}$$

$$= \frac{(n-1)A's}{nA_s} = \frac{(9.66-1) \times 1.539}{9.66 \times 2 \times 0.785} = 0.879$$

$$I_g = \frac{bh^3}{12} = \frac{20 \times 13.5^3}{12} = 4100.63 \text{ cm}^4$$

$$kd = \frac{\sqrt{2dB\left(1 + \frac{d'}{d}\right) + (1 +)^2} - (1 +)}{B}$$

$$= \frac{\sqrt{\left(2 \times 10.5 \times 1.319 \times \left(1 + \frac{0.879 \times 3.70}{10.5}\right) + (1 + 0.879)^2\right)} - (1 + 0.879)}{1.319}$$

$$= \frac{1 + 0.879}{1.319} = 3.36 \text{ cm}$$

$$I_{cr} = \frac{b \cdot kd^3}{3} + nA_s(d - kd)^2 + (n-1)A's(kd - D)^2$$

$$= \frac{20 \times 3.36^3}{3} + 9.66 \times 2 \times 0.785 \times (10.5 - 3.36)^2$$

$$+ 9.66 \times 1.539 \times (3.36 - 3.70)^2$$

$$= 252.89 + 773.17 + 1.72 = 1027.78 \text{ cm}^4$$

③ 부 모멘트 단면 산정

$$d = 13.5 - T.C - 1.0 - \frac{D_1}{2} = 13.5 - 2.0 - 1.0 - 0.7 = 9.80 \text{ cm}$$

$$d' = B.C + \frac{D_1}{2} = 2.5 + 0.50 = 3.00 \text{ cm}$$

$$B = \frac{b}{nA_s} = \frac{20}{9.66 \times 1.539} = 1.35 \text{ cm}$$

$$= \frac{(n-1)A's}{nA_s} = \frac{(9.66-1) \times 2 \times 0.785}{9.66 \times 1.539} = 0.915$$

$$I_g = \frac{bh^3}{12} = \frac{20 \times 13.5^3}{12} = 4100.63 \text{ cm}^4$$

$$kd = \frac{\sqrt{2dB \left(1 + \frac{d'}{d}\right) + (1 +)^2 - (1 +)}}{B}$$

$$= \frac{\sqrt{\left(2 \times 9.8 \times 1.35 \times \left(1 + \frac{0.915 \times 3.0}{9.8}\right) + (1 + 0.915)^2\right)}}{1.35}$$

$$= \frac{1 + 0.915}{1.35} = 3.12 \text{ cm}$$

$$I_{cr} = \frac{b \cdot kd^3}{3} + nA_s(d - kd)^2 + (n-1)A's(kd - D')^2$$

$$= \frac{20 \times 3.12^3}{3} + 9.66 \times 1.539 \times (9.8 - 3.12)^2$$

$$+ (9.66 - 1) \times 2 \times 0.785 \times (3.12 - 3.0)^2$$

$$= 202.48 + 663.39 + 0.2 = 866.07 \text{ cm}^4$$

④ 유효 단면 2 차 모멘트 산정

$$M_{cr} = \frac{f_r \cdot I_g}{y_t} = \frac{28.980 \times 4100.63}{13.5/2} = 17605.37 \text{ kgf} \cdot \text{cm}$$

$$0.176 \text{ tf} \cdot \text{m}$$

$$\frac{M_{cr}}{M_D} = \frac{0.176}{0.120} = 1.47 > 1.0 \quad I_{e(D)} = I_g \text{ 사용}$$

$$\frac{M_{cr}}{M_{sus}} = \frac{0.176}{0.169} = 1.04 > 1.0 \quad I_{e(sus)} = I_g \text{ 사용}$$

$$\frac{M_{cr}}{M_{D+L}} = \frac{0.176}{0.217} = 0.81 < 1.0$$

$$\begin{aligned} I_{e(D+L)} &= \left(\frac{M_{cr}}{M_{D+L}} \right)^3 I_g + \left[1 - \left(\frac{M_{cr}}{M_{D+L}} \right)^3 \right] I_{cr} \\ &= 0.81^3 \times 3661.67 + (1 - 0.81^3) \times 1027.78 = 2660.82 \end{aligned}$$

$$M_{cr} = \frac{f_r \cdot I_g}{y_t} = \frac{28.980 \times 3661.67}{13/2} = 16325.41 \text{ kgf} \cdot \text{cm}$$

$$0.163 \text{ tf} \cdot \text{m}$$

$$\frac{M_{cr}}{M_D} = \frac{0.176}{0.169} = 1.04 > 1.0 \quad I_{e(D)} = I_g \text{ 사용}$$

$$\frac{M_{cr}}{M_{sus}} = \frac{0.176}{0.237} = 0.74 < 1.0$$

$$\begin{aligned} I_{e(sus)} &= \left(\frac{M_{cr}}{M_{sus}} \right)^3 I_g + \left[1 - \left(\frac{M_{cr}}{M_{sus}} \right)^3 \right] I_{cr} \\ &= 0.74^3 \times 4100.63 + (1 - 0.74^3) \times 866.07 = 2176.79 \end{aligned}$$

$$\frac{M_{cr}}{M_{D+L}} = \frac{0.176}{0.305} = 0.58 < 1.0$$

$$\begin{aligned} I_{e(D+L)} &= \left(\frac{M_{cr}}{M_{D+L}} \right)^3 I_g + \left[1 - \left(\frac{M_{cr}}{M_{D+L}} \right)^3 \right] I_{cr} \\ &= 0.58^3 \times 4100.63 + (1 - 0.58^3) \times 866.07 = 1497.17 \end{aligned}$$

⑤ 평균 단면 2 차 모멘트

$$Avg(I_e) = 0.85 \cdot I_m + 0.15 \cdot (I_{CONT.END}) < I_g$$

$$Avg(I_e)_D = 0.85 \cdot 4100.63 + 0.15 \cdot 4100.63 = 4100.63 \text{ cm}^4$$

$$Avg(I_e)_{SUS} = 0.85 \cdot 4100.63 + 0.15 \cdot 2176.79 = 3812.06 \text{ cm}^4$$

$$Avg(I_e)_{D+L} = 0.85 \cdot 2660.82 + 0.15 \cdot 1497.171 = 2486.27 \text{ cm}^4$$

⑥ 단기 처짐 (ai)

$$\begin{aligned} a_{i(D)} &= K \frac{5}{48} \cdot \frac{M_D \cdot I_x^2}{(E_c \cdot I_{e(D)})} \\ &= 0.85 \times \frac{5}{48} \times \frac{12000 \times 440^2}{2.174 \times 10^5 \times 4100.63} = 0.23 \text{ cm} \end{aligned}$$

$$\begin{aligned} a_{i(SUS)} &= K \frac{5}{48} \cdot \frac{M_{SUS} \cdot I_x^2}{(E_c \cdot I_{e(SUS)})} \\ &= 0.85 \times \frac{5}{48} \times \frac{16900 \times 440^2}{2.174 \times 10^5 \times 3812.06} = 0.35 \text{ cm} \end{aligned}$$

$$\begin{aligned} a_{i(D+L)} &= K \frac{5}{48} \cdot \frac{M_{D+L} \cdot I_x^2}{E_c \cdot I_{e(D+L)}} \\ &= 0.85 \times \frac{5}{48} \times \frac{21700 \times 440^2}{2.174 \times 10^5 \times 2486.27} = 0.69 \text{ cm} \end{aligned}$$

$$a_{i(L)} = a_{i(D+L)} - a_{i(D)} = 0.69 - 0.23 = 0.46 \text{ cm}$$

$$K = 1.2 - 0.2 \frac{M_0}{M_a} = 1.2 - 0.2 \left[\frac{\frac{W I_x^2}{8}}{\frac{W I_x^2}{14}} \right] = 0.85$$

4.3.1 1 (6)

$$allow = \frac{I_x}{360} = \frac{400}{360} = 1.22 \text{ cm} > a_{i(L)} = 0.46 \text{ cm} \quad \text{O.K}$$

⑦ 장기 처짐

($a_{(cp+sh)}$)

$$= \frac{2.0}{(1 + 50)} = \frac{2.0}{(1 + 50 \times 0.0059)} = 1.54$$

$$= \frac{A'_s}{A} = \frac{1.539}{(13 \times 20)} = 0.0059$$

= 2.0 (5년 이상 지속 하중으로 작용할 경우로 가정)

$$a_{(cp+sh)} = \cdot a_{i(SUS)} = 1.54 \times 0.35 = 0.54 \text{ cm}$$

$$a_{(cp+sh)} + a_{i(L)} = 0.54 + 0.46 = 1.00 \text{ cm}$$

가

$$allow = \frac{I_x}{240} = \frac{440}{240} = 1.83 \text{ cm}$$

$$> a_{(cp+sh)} + a_{i(L)} = 1.00 \text{ cm} \quad O.K$$

4.3.1 1 (6)

(5) 트러스데크(A3-75) 주근 검토

㉠ 상부 철선

$$D 14, a_1 = 1.539 \text{ cm}^2, f_y = 5000 \text{ kgf/cm}^2$$

$$f'_c = 210 \text{ kgf/cm}^2, d = 9.30 \text{ cm}$$

$$R_u = \frac{M_{x1} \times 10^5}{100 \times d^2} = \frac{2.33 \times 10^5}{100 \times 9.80^2} = 24.26 \text{ kgf/cm}^2$$

$$R_n = \frac{R_u}{0.9} = 26.96 \text{ kgf/cm}^2$$

$$= \frac{0.85 f_{ck}}{f_y} \times \left(1 - \sqrt{1 - \frac{2R_n}{0.85 f_{ck}}} \right)$$

$$= \frac{0.85 \times 210}{5000} \times \left(1 - \sqrt{1 - \frac{2 \times 26.96}{0.85 \times 210}} \right) = 0.00587$$

$$A_s = \times 100 \times d = 0.00587 \times 100 \times 9.80 = 5.76 \text{ cm}^2$$

$$A_{s,\min} = \frac{14}{f_y b_w d} = \frac{14}{5000 \times 100 \times 9.8} = 2.75 \text{ cm}^2 \quad (6.3.2)$$

$$s = \frac{a_c \times 100}{A_s} = \frac{1.539 \times 100}{5.76} = 26.72 \text{ cm} > 20 \text{ cm} \quad - O.K -$$

㉡ 하부 철선

$$2 - D10, a_2 = 1.57 \text{ cm}^2, f_y = 5000 \text{ kgf/cm}^2$$

$$f'_c = 210 \text{ kgf/cm}^2, d = 10.0 \text{ cm}$$

라. 추가 보강근을 배근하는 경우의 설계 예 (L=2.7m)

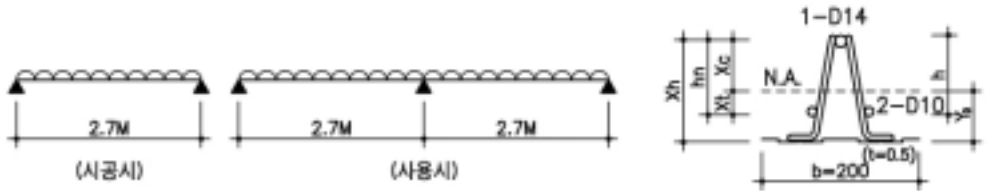

(1) 구조 재료의 규격 및 기준 강도

▪	$f_{ck} = 210 \text{ kgf/cm}^2$
▪	$f_y = 5,000 \text{ kgf/cm}^2$
▪	
▪	
▪	30 cm
▪	15.0 cm
▪	: 2 cm : 2.5 cm (가)
▪	A3-95 (t=0.5 mm)

(2) 설계 하중

㉠ 시공시 설계 하중

		(kgf/m ²)	(kgf/m ²)
	(t=150)	345.0	345.0
		25.0	25.0
		$345 \times 0.25=86.0$	0.0
		150.0	100.0
		606.0	470.0

50% 25%

㉢ 건물 사용시 설계 하중 (단위 : kgf/m²)

	(t = 1 5 0)	345.0
		25.0
	, ,	345.0
		2000.0
		2715.0

(3) 슬래브 설계

④ 시공시의 단면 산정

① 트러스테크(A3-95 삼각-트러스형)의 역학적 성능

◆ : $b = 20 \text{ cm}$

◆

(D14)

$$a_1 = 1.539 \text{ cm}^2$$

$$D_1 = 1.4 \text{ cm}$$

(D10)

$$a_2 = 0.785 \times 2 = 1.57 \text{ cm}^2, \quad D_2 = 1.0 \text{ cm}$$

◆

(D10)

$$a_2 = 0.785 \times 2 = 1.57 \text{ cm}^2, \quad D_2 = 1.0 \text{ cm}$$

(D14)

$$: a_1 = 1.539 \text{ cm}^2, \quad D_1 = 1.4 \text{ cm}$$

◆ DECK PLATE

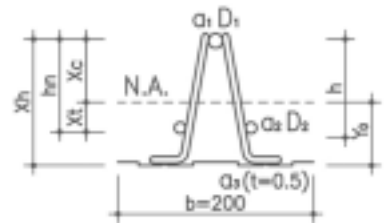

② 중립축 위치 산정

$$Y_0 = \frac{a_1 \cdot X_h + a_2 \cdot \left(\frac{D_2}{2} + B.C \right)}{a_1 + a_2}$$

$$= \frac{(1.539 \times 11.3) + (0.785 \times 2 \times 3.0)}{1.539 + 1.57} = 7.11 \text{ cm}$$

$$X_c = X_h - Y_0 = 11.3 - 7.11 = 4.19 \text{ cm}$$

$$X_t = h_n - X_c = 8.3 - 4.19 = 4.11 \text{ cm}$$

$$X_h = h + B.C - \frac{D_1}{2} = 9.5 + 2.5 - \frac{1.4}{2} = 11.3 \text{ cm}$$

B.C : BOTTOM COVER

㉞ 단면 2 차 모멘트

$$\begin{aligned} I_o &= \left[\frac{D_1^4}{64} + a_1 \times X_c^2 + \frac{D_2^4}{64} \times 2 + a_2 \times X_t^2 \right] \times \frac{100}{b_1} \\ &= \left[\frac{\times 1.4^4}{64} + 1.539 \times 4.19^2 + \frac{\times 1.0^4}{64} \times 2 + 2 \times 0.785 \times 4.11^2 \right] \times \frac{100}{20} \\ &= 53.83 \times \frac{100}{20} = 269.14 \text{ cm}^4/\text{m} \end{aligned}$$

㉟ 단면 계수

$$Z_c = \frac{I_o}{X_c} = \frac{269.14}{4.19} = 64.23 \text{ cm}^3$$

$$Z_t = \frac{I_o}{X_t} = \frac{269.14}{4.11} = 65.49 \text{ cm}^3$$

㊱ 상부 철선의 압축 강도 (장기)

$$D14 \quad : \quad a_2 = 1.539 \text{ cm}^2$$

$$2 \quad : \quad I_o = \frac{D^4}{64} = \frac{\times 1.4^4}{64} = 0.189 \text{ cm}^4$$

$$2 \quad : \quad i = \sqrt{\frac{I_o}{a_2}} = \sqrt{\frac{0.189}{1.539}} = 0.35 \text{ cm}$$

$$(\quad) : l_1 = 20 \text{ cm}$$

$$: \quad = \frac{l_1}{i} = \frac{20}{0.35} = 57.0$$

$$: \quad \rho = \sqrt{\frac{^2 E}{0.6 f_y}} = \sqrt{\frac{^2 \times 2100}{0.6 \times 5.0}} = 83.12$$

$$: \quad \rho$$

$$\begin{aligned}
s f_c &= \left[1 - 0.4 \left(\frac{\quad}{\rho} \right)^2 \right] \cdot \frac{f_y}{n} \\
&= \left[1 - 0.4 \left(\frac{57.14}{83.12} \right)^2 \right] \times \frac{5}{1.82} \\
&= 2.22 \text{ tf/cm}^2 \quad 2.2 \text{ tf/cm}^2 \\
n &= \frac{3}{2} + \frac{2}{3} \left(\frac{\quad}{\rho} \right)^2 = \frac{3}{2} + \frac{2}{3} \left(\frac{57.14}{83.12} \right)^2 = 1.82 \\
F_y &= 4,000 \text{ kgf/cm}^2 \quad , \quad D \quad 25 \text{ mm} \\
2,200 \text{ kgf/cm}^2 \quad .(\quad)
\end{aligned}$$

③ 래티스재의 압축 강도

$$\begin{aligned}
(5) : a_1 &= 0.196 \text{ cm}^2 \\
2 : I_o &= \frac{D^4}{64} = \frac{\quad \times (0.5^4)}{64} = 0.0031 \text{ cm}^4 \\
2 : i &= \sqrt{\frac{I_o}{a_1}} = \sqrt{\frac{0.0031}{0.196}} = 0.13 \text{ cm} \\
: I_2 &= \sqrt{\left(\frac{I_1}{2} \right)^2 + h_n^2} = \sqrt{10.0^2 + 8.3^2} = 13 \text{ cm} \\
: &= \frac{I_2}{i} = \frac{13}{0.13} = 100 \\
: \rho &= \sqrt{\frac{2E}{0.6 f_y}} = \sqrt{\frac{2 \times 2100}{0.6 \times 5.0}} = 83.12 \\
: &> \rho \\
s f_c &= \frac{0.277 f_y}{\left(\frac{\quad}{\rho} \right)^2} = \frac{0.277 \times 5.0}{\left(\frac{100}{83.12} \right)^2} = 0.96 \text{ tf/cm}^2 \\
: \\
&= \tan^{-1} \left(\frac{h_n}{\frac{I_1}{2}} \right) = \tan^{-1}(0.83) = 40^\circ
\end{aligned}$$

㉞ 시공시 처짐 검토

$$l_x = L - \text{보폭} + \text{지점이동거리} = 2.7 - 0.2 + 0.15 = 2.65 \text{ m}$$

3.4.5 (1)

$$W = 0.606 \text{ tf/m}^2$$

$$= \frac{5 W l_x^4}{384 E I_0} = \frac{5 \times 0.606 \div 100 \times 265^4}{384 \times 2100 \times 269.14} = 0.69 \text{ cm} < 1.0 \text{ cm} \quad O.K$$

㉟ 시공시 철선의 응력 검토.

$$l_x = L - \text{보폭} + \text{지점이동거리} = 2.7 - 0.2 + 0.15 = 2.65 \text{ m}$$

3.4.5 (1)

$$W = 0.2 \times 0.606 = 0.121 \text{ tf/m}$$

$$M = \frac{W \cdot l_x^2}{8} = \frac{0.121 \times 2.65^2}{8} = 0.106 \text{ tf} \cdot \text{m}$$

$$V = \frac{5 \cdot W \cdot l_x}{8} = \frac{0.121 \times 2.65}{2} = 0.16 \text{ tf}$$

① 상부 철선 (압축)

$$\frac{c}{s f_c} = \frac{100 \cdot M}{Z_c \cdot s f_c \cdot 1.5} = \frac{100 \times 0.106}{\left(\frac{64.23}{5}\right) \times 2.2 \times 1.5} = 0.25 < 1.0 \quad O.K$$

② 하부 철선 (인장)

$$\frac{t}{s f_t} = \frac{100 \cdot M}{Z_t \cdot s f_t \cdot 1.5} = \frac{100 \times 0.106}{\left(\frac{65.49}{5}\right) \times 2.2 \times 1.5} = 0.25 < 1.0 \quad O.K$$

③ 래티스재

$$N_c = \frac{V}{\sin} = \frac{0.16}{\sin 40^\circ} = 0.25 \text{ tf}$$

$$c = \frac{0.5 \times N_c}{a_c} = \frac{0.5 \times 0.25}{0.196} = 0.64 \text{ tf/cm}^2$$

$$\frac{c}{s f_c \times 1.5} = \frac{0.64}{0.96 \times 1.5} = 0.45 < 1.0 \quad O.K$$

(4) 건물 사용시의 단면 산정

㉠ 건물 사용시 하중 조합

$$W_u = 1.4 \times \text{고정하중} + 1.7 \times \text{활하중}$$

$$= 1.4 \times 0.715 + 1.7 \times 2.0 = 4.401 \text{ tf/m}^2$$

$$W_1 = 1.4 \times \text{추가하중} + 1.7 \times \text{활하중}$$

$$= 1.4 \times 0.345 + 1.7 \times 2.0 = 3.88 \text{ tf/m}^2$$

$$W_2 = 1.4 \times (\text{고정하중} - \text{추가하중})$$

$$= 1.4 \times (0.715 - 0.345) = 0.518 \text{ tf/m}^2$$

㉡ 휨 모멘트 산정 (TWO SPAN 연속)

$$l_x = 2.70 - 0.20(\text{보폭}) + 0.15(\text{지점이동거리}) = 2.65 \text{ m} \quad 3.4.5(2)$$

MAX. NEG. MOMENT()

$$M_{x1} = \frac{W_u \times l_x^2}{9} = \frac{4.4 \times 2.65^2}{9} = 3.43 \text{ tf} \cdot \text{m} \quad 3.4.1 \quad (4) \quad (\text{가})$$

2

MAX. POS. MOMENT()

$$M_{x2} = \frac{W_1 \times l_x^2}{11} = \frac{3.88 \times 2.65^2}{11} = 2.48 \text{ tf} \cdot \text{m} \quad 3.4.1 \quad (4) \quad (\text{가})$$

가

$$M_{x3} = \frac{W_2 \times l_x^2}{8} = \frac{0.518 \times 2.65^2}{8} = 0.455 \text{ tf} \cdot \text{m}$$

㉢ 사용시 하중에 의한 처짐 검토

가 1

$$\frac{L}{24} = \frac{265}{24} = 11.04 \text{ cm} < 15 \text{ cm}$$

4.3.1 1 (1)

㉔ 트러스데크(A3-75) 주근 검토

① 상부 철선

$$D14, a_1 = 1.539 \text{ cm}^2, f_y = 5000 \text{ kgf/cm}^2$$

$$f'_c = 210 \text{ kgf/cm}^2, d = 9.30 \text{ cm}$$

$$R_u = \frac{M_{x1} \times 10^5}{100 \times d^2} = \frac{4.4 \times 10^5}{100 \times 11.3^2} = 34.46 \text{ kgf/cm}^2$$

$$R_n = \frac{R_u}{0.9} = 38.29 \text{ kgf/cm}^2$$

$$\begin{aligned} &= \frac{0.85 f_{ck}}{f_y} \times \left(1 - \sqrt{1 - \frac{2R_n}{0.85 f_{ck}}} \right) \\ &= \frac{0.85 \times 210}{5000} \times \left(1 - \sqrt{1 - \frac{2 \times 38.29}{0.85 \times 210}} \right) = 0.0087 \end{aligned}$$

$$A_s = \rho \times 100 \times d = 0.0087 \times 100 \times 11.3 = 9.83 \text{ cm}^2$$

$$A_{s,\min} = \frac{14}{f_y b_w d} = \frac{14}{5000 \times 100 \times 11.3} = 3.17 \text{ cm}^2 \quad (6.3.2)$$

$$s = \frac{a_c \times 100}{A_s} = \frac{1.539 \times 100}{9.83} = 15.66 \text{ cm} < 20 \text{ cm} \quad N.G$$

HD13@200

$$s = \frac{a_c \times 100}{A_s} = \frac{\left(1.539 + 1.27 \times \frac{4}{5} \right) \times 100}{9.83} = 25.99 \text{ cm} > 20 \text{ cm} \quad O.K$$

$$f_y = 4,000 \text{ kgf/cm}^2$$

② 하부 철선

$$2 - D10, a_2 = 1.57 \text{ cm}^2, f_y = 5000 \text{ kgf/cm}^2$$

$$f'_c = 210 \text{ kgf/cm}^2, d = 10.0 \text{ cm}$$

II. 트러스데크의 구조 설계 및 시공 지침

1. 일반 사항

가. 적용 범위

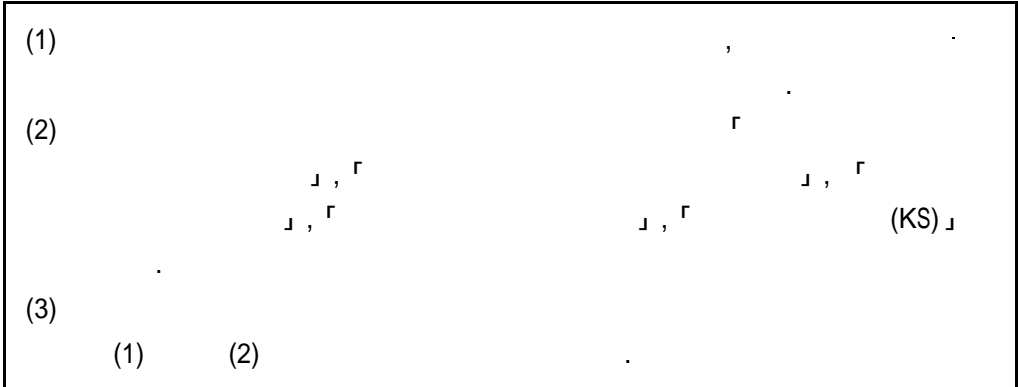

[해 설]

(2)

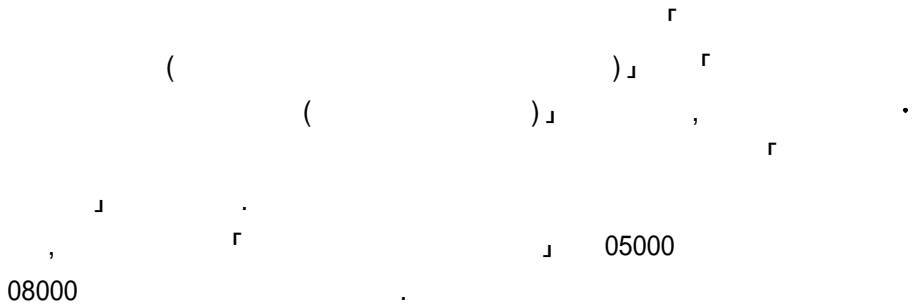

(3)



나. 용어의 정의

(1) (Strength reduction factor)

- 가 . 1.0
- (2) (Nominal strength)
가
- (3) (Structural welded wire fabric)
- (4) 가 .
- (5) (Service load)
- (6) (Upper chord, Top chord)
- (7) (Sleeper)
- (8) (Wire rod)
KS D 3354()
0.25%
- (9) (Elongation) (
- (10) (Temperature Wire)
- (11) (Welding point shear strength)
- (12) (Development length)

(13) (Vertical bar)

(14) (Wire)

KS D 3552()

가 가

(15) (Crank)

Z

(16) (Final gauge length)

(17) (Load factor)

1.0

(18) (Load combination)

(19) (Lower chord)

(20) (Yield strength)

(21) (Fleshing)

다. 기호

(1) d_b

(2) D

- (3) f_y ()
- (4) F_y ()
- (5) I_d
- (6) I_{db}
- (7) I_n
- (8) M_n
- (9) M_u
- (10) W_c
- (11) W_u
- (12) a_m
- (13)
- (14)
- (15) s
- (16)
- (17) \min
- (18) ,
- (19) i 2
- (20) p
- (21) f_c
- (22)
- (23) c
- (24) m .

2. 재 료

가. 철 선

(1)	KSD 3554	가
(2)	2	(KSD 3552-)
(3)	:	2 ()
(4)	:	,
(4)		KSB 0802, KSB 0803, KSB 0804

나. 이형 철선

(1)	,	KS D 3552(), KSD 7017()
(2)	가	,
(3)	[2.1]	,
(3)		KS B 0802, KS B 0803, KS B 0804 ,
	0.2%	[2.1]

[2.1]

공칭명	공 칭 선 지름 (mm)	공 칭 단 면 적 (mm)	단 무 위 계 (kg/m)	기 계 적 성 질			비 고
				항 복 접 (N/mm ²)	인 장 도 (N/mm ²)	연 신 율	
D-6	6.0	28.3	0.222 ± 8%	500	550	12	
D-7	7.0	38.5	0.302 ± 8%	500	550	12	
D-8	8.0	50.3	0.395 ± 8%	500	550	12	
D-9	9.0	63.8	0.499 ± 5%	500	550	12	
D-10	10.0	78.5	0.560 ± 6%	500	550	12	

D-11	11.0	95	0.746 ± 5%	500	550	12	
D-12	12.0	113.1	0.888 ± 5%	500	550	12	
D-13	12.7	126.7	0.995 ± 6%	500	550	12	

다. 이형 철선의 표준 길이

[2.2] (: m)

3.5	4.0	4.5	5.0	5.5	6.0	6.5	7.0	8.0	9.0	10.0	11.0	12.0
-----	-----	-----	-----	-----	-----	-----	-----	-----	-----	------	------	------

라. 이형 철선 길이의 허용차

[2.2]

길이	이	길이의 허용차
7.0 m		+40.0 mm 0
7.0 m	1 m 5 mm	가 가 120 mm

()

가
가 0.2%

마. 원형 철선

(1)	(KS D 3554)	, KS D 3552()
(2)		5-6 mm [2.4]
(3)	2.5]	[

(4)	[2.4]
(5)	5 ($5d_b$), 12%
(6)	25 mm
180°	

[해 설]

(2) 500 mm 가

[.1]

여기서, G : 철선의 중량 (g)
 l : 철선의 길이 (mm)

[2.4] (: mm)

선지름	허용오차
6.00	± 0.10
6.00	± 0.13

(3)

[2.5]

공 칭 명	공 칭 선지름 (mm)	허 용 차	공 칭 단면적 (mm^2)	단 위 계 (kg/m)	기 계 적 성 질			비 고
					항 복 점 (N/mm^2)	인 장 강 도 (N/mm^2)	연 신 율	
5	5 mm	± 0.10	19.6	$0.154 \pm 9\%$	500	550	8	
6	6 mm	± 0.10	28.3	$0.222 \pm 8\%$	500	550	8	

(4) $56.2 \text{ kgf/mm}^2 (550 \text{ N/mm}^2)$

, 0.5%

가 $50 \text{ kgf/mm}^2 (500 \text{ N/mm}^2)$

(5)

, 가

60° 가

6 (6db)

3. 트러스데크

가. 일반 사항

(1)	가
(2)	(KSD 3506) , , [2.6] (KS) .

[2.6]

종 류 및 기 호	표시두께	도 금 부 착 량 표시기호	아 연 부 착 량 (g/m)		항 복 점 N/mm ²	인 장 강 도 N/mm ²	연 신 율
			평균치	최소치			
SGC-570	0.5 ± 0.06	Z 12	120	102	560	570	

나. 형상 및 치수

(1)	, , .
(2)	600 mm, 200 mm, 0.5 mm, (h) 70~280 mm .

다. 종류

(1)	[2.7] 12가 TYPE .
-----	--------------------

[해 설]

(h) , 120~330 mm 가 ,
 h= - - -10(.
) .

[2.7]

	상 부 철 선	하 부 철 선	LATTICE
A1-TYPE	1-D10	2-D 7	5
A2-TYPE	1-D12	2-D 8	
A3-TYPE	1-D14	2-D10	
A4-TYPE	1-D10	2-D 6	
A5-TYPE	1-D12	2-D 7	
A6-TYPE	1-D14	2-D 8	
A1a-TYPE	1-D10	2-D 7	6
A2a-TYPE	1-D12	2-D 8	
A3a-TYPE	1-D14	2-D10	
A4a-TYPE	1-D10	2-D 6	
A5a-TYPE	1-D12	2-D 7	
A6a-TYPE	1-D14	2-D 8	

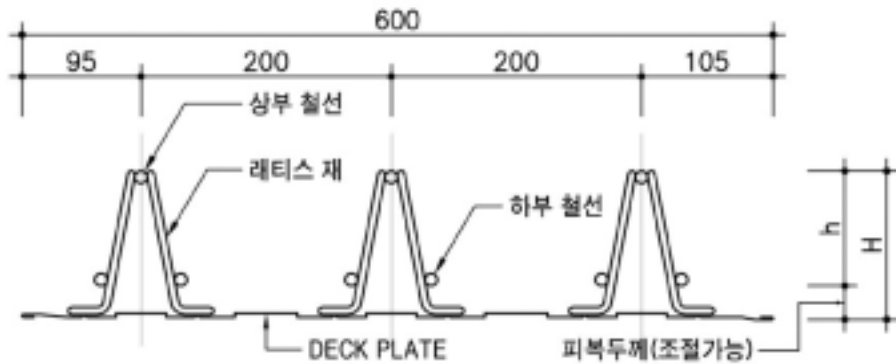

[2.1]

라. 허용차

(1)	[2.8]
(2)	[2.9]

[해 설]

(1)

[2.8]

트러스데크의 길이	나 비 허용 차	길 이 허 용 차
5.0 m	±5 mm	±2 mm
5.0 m		±3 mm

(2)

[2.9]

구	분	허 용 차
높	이	±3 mm
트 러 스 근 의	간 격	±5 mm
래 터 스 재 의 용 접 점 간 의	거 리	±2 mm

마. 재료 시험

(1)	.
(2)	(), ,
(3)	,
3	.
(4)	가

(5)
(KS)

[해 설]

(1)
(Quality control) (Quality improvement) 가
가

(2) KS B 0802 () ,
0.5% 가 2/3
1~3 N/mm²/s 가 , 0.025%/S ~ 0.25%/s
가 KS B 0804()

180° ,
20° 가
(5) ,

4. 구조 설계

가. 일반 사항

(1) _____ 가 _____ , _____ .

[해 설]

[3.1] _____ .

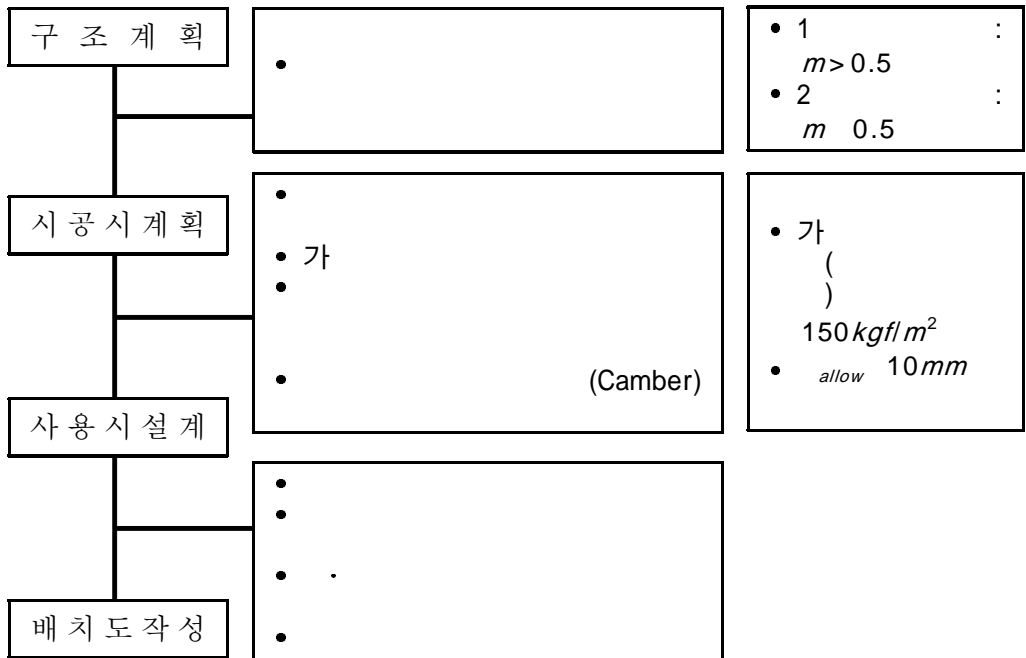

[3.1] _____

나. 구조 계획 및 해석

(1) 구조 계획

(1) _____ , _____ .

(2) 구조 해석

(1)

(3) SPAN

(1)

[해 설]

(1) 가 . 가

다. 설계 하중

(1) 일반 사항

(1)

(2) 하중 상태의 고려

(1)

(3) 시공시 하중

5. 구조 계산

가. 기본 방침

(1) 시공시의 하중 조합 및 지점

(1)	
(2)	가 .

[해 설]

(1)

[3.2]

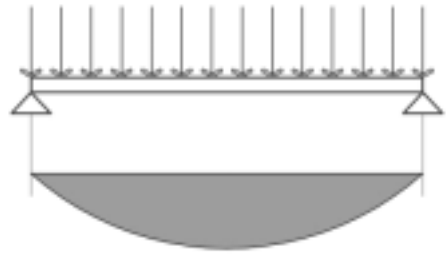

ONE SPAN

$$: W(\quad) = D.L (R.C + \quad) + L.L(\quad)$$

$$: W(\quad) = D.L (R.C + \quad) + L.L(\quad)$$

(2) 사용시의 하중 조합 및 지점

(1)	
(2)	TWO-SPAN
(3)	TWO-SPAN

(SPAN)
[3.4]

[해 설]

(1)

가 가

(2) 가

ONE-SPAN , TWO-SPAN

가

가

SPAN

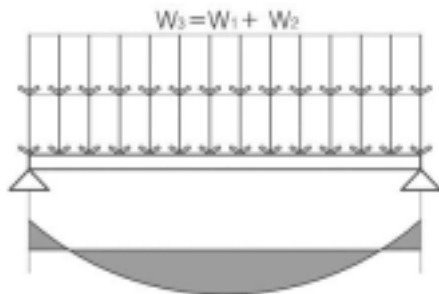
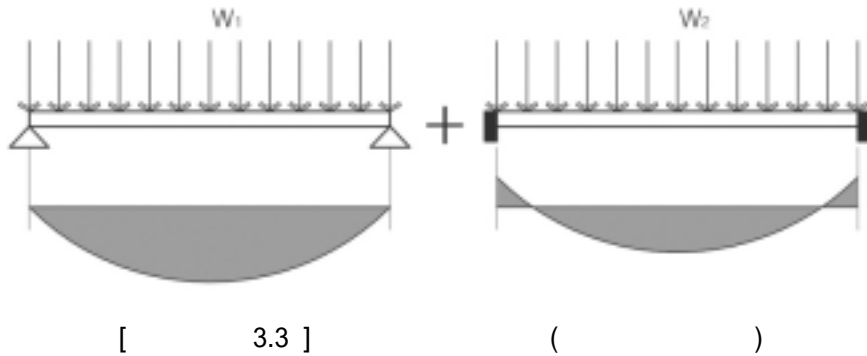

6. 시공시 구조 계산

가. 일반 사항

(1)	가	. . .
		1
	(ONE-SPAN TWO-SPAN) 가	. . .

[해 설]

가

가 .

나. 시공시 단면 산정

(1) 처짐의 검토

(1)	(Camber)	. . .
(2)		(allow) 10
	mm .	

[해 설]

TWO-SPAN

(Camber) 가

$$a_{ct} = \frac{5 W L^4}{384 E I} \cdot c$$

(2) 응력의 검토

(1)	「	」
		가 .

[해 설]

$$(F_y = 5,000 \text{ kgf/cm}^2) \qquad \qquad \qquad 2,200 \text{ kgf/cm}^2$$

(M), (V), (N)

$$M = \frac{W l^2}{8} \qquad \qquad \qquad (3.3)$$

$$N = \frac{M}{H} \qquad \qquad \qquad (3.4)$$

$$V = \frac{W l}{2} \qquad \qquad \qquad (3.5)$$

(3) 상부 철선 검토

[3.6] [

3.7]

$$f_c = \frac{\left[1 - 0.4 \times \left(\frac{\rho}{f_c} \right)^2 \right]}{n} \times F_y \qquad \qquad \qquad (3.6)$$

, f_y :

$$i = \sqrt{\frac{I_0}{A}}, \quad = \frac{l}{i}, \quad \rho = \sqrt{\frac{2E}{0.6 F_y}}$$

$$Z_c = \frac{I_0}{X_c}, \quad Z_t = \frac{I_0}{X_t}, \quad n = \frac{3}{2} + \frac{2}{3} \left[\frac{\rho}{f_c} \right]^2 \frac{13}{6}$$

> ρ f_c

$$f_c = \frac{0.277 F_y}{\left(\frac{\rho}{f_c} \right)^2} \qquad \qquad \qquad (3.7)$$

$$c = \frac{M}{Z} = \frac{M}{Z_c \times f_c \times 1.5} < 1.0 \quad (3.8)$$

(4) 하부 철선 검토

$$t = \frac{M}{Z} = \frac{M}{Z_t \times f_t \times 1.5} < 1.0 \quad (3.9)$$

(5) 래티스재의 검토

[3.11]

$$N_c = \frac{V}{\sin} \quad (3.10)$$

$$c = \frac{N_c}{a_t} \frac{c}{f_c \times 1.5} < 1.0 \quad (3.11)$$

7. 사용시 구조 계산

가. 일반 사항

(1)		
(2)	가 0.5	1, 2

[해 설]

(2)

2

가

나. 수축 및 온도 철근

(1)		
(2)	「 」	5.7.2 1
	$f_y < 4000 \text{ kg/cm}^2$, $\min = 0.0020$
	$f_y > 4000 \text{ kg/cm}^2$, $\min = \frac{0.0020 \times 4000}{f_y} = 0.0014$
(3)	5	40 cm

[해 설]

◎ f_y 가 $4,000 \text{ kgf/cm}^2$

$$h = 0.43 + \frac{f_y}{7,000}$$

1 (1

)

2 가 20%

3

가

$$\dots\dots\dots \frac{W_u \cdot I_n^2}{11}$$

$$\dots\dots\dots \frac{W_u \cdot I_n^2}{14}$$

$$\dots\dots\dots \frac{W_u \cdot I_n^2}{16}$$

가 $\dots\dots\dots \frac{W_u \cdot I_n^2}{24}$

가 $\dots\dots\dots \frac{W_u \cdot I_n^2}{16}$

2 $\dots\dots\dots \frac{W_u \cdot I_n^2}{9}$

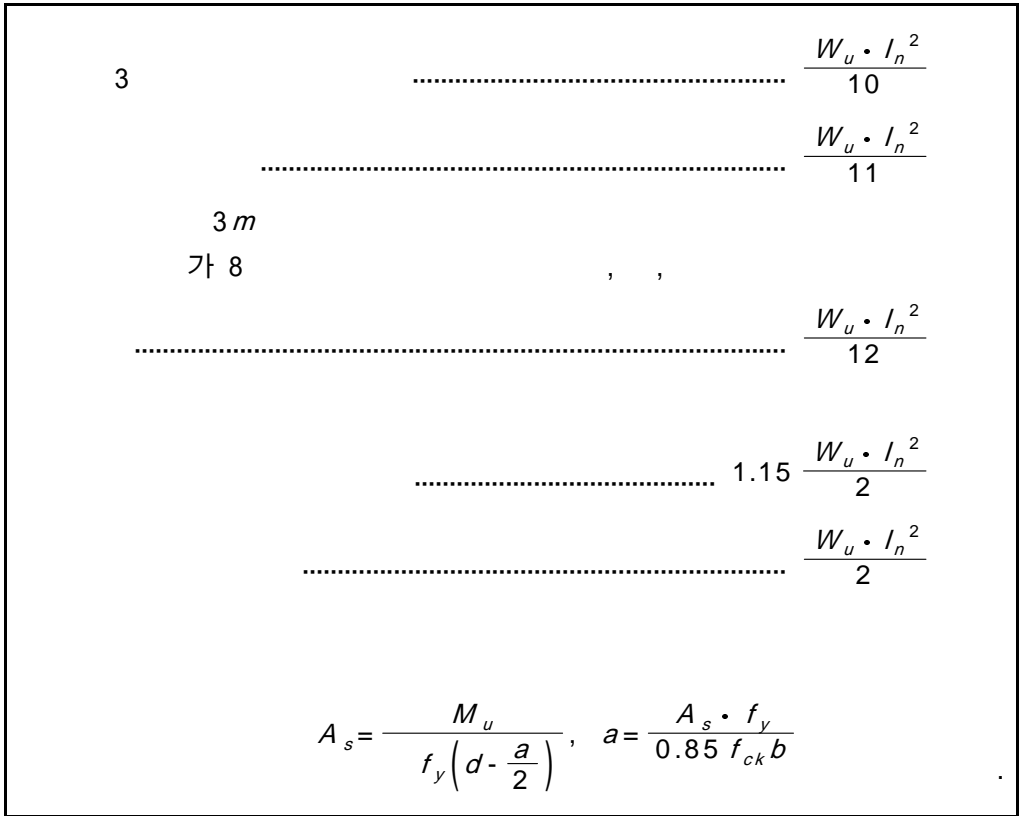

[해 설]

(1) 1 1

(2) [3.5]

(3) 1

가

3.3 m : 120 mm

3.4 ~ 3.9 m : 135 mm

4.0 m ~ 4.5 m : 160 mm

4.6 m ~ 4.9 m : 200 mm

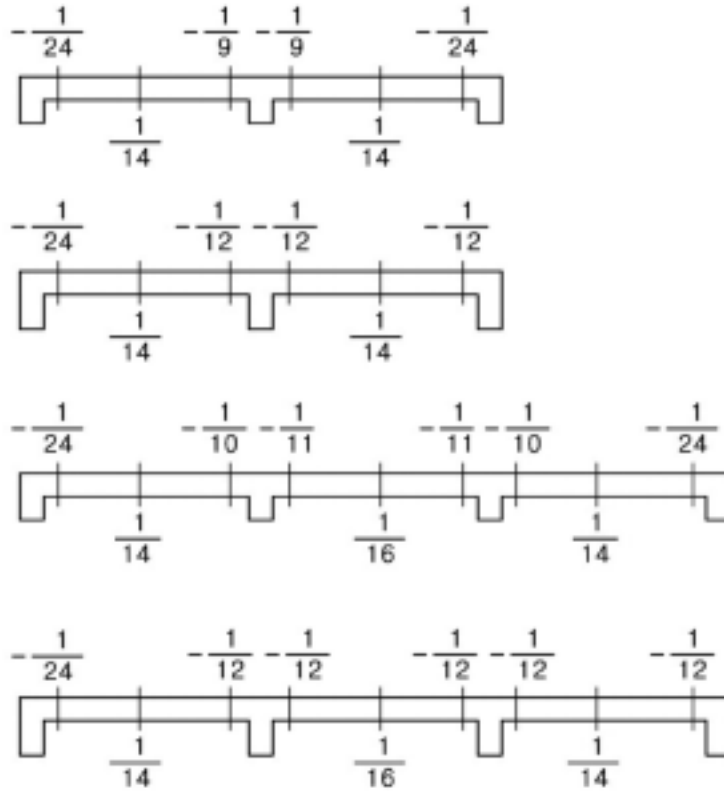

[3.5]

(4) A_s .

$$R_n = \frac{M}{b \cdot d}$$

$$= \left(1 - \sqrt{1 - \frac{2R_n}{0.85f_{ck}}} \right) \cdot \frac{0.85f_{ck}}{f_y} > \min$$

$$A_s = \cdot b \cdot d$$

라. 2방향 슬래브

(1) 2

(2) $m = 0.2$ 가

$m = 0.2$ 2.0 (3.1)
12cm

$$h = \frac{I_n \left(800 + \frac{f_y}{14} \right)}{36,000 + 5,000 (m - 0.2)} \quad (3.1)$$

$m = 2.0$ (3.2)
9cm

$$h = \frac{I_n \left(800 + \frac{f_y}{14} \right)}{36,000 + 5,000} \quad (3.2)$$

0.8

10% (3.1) (3.2)

m :
: 2

(3) [3.2] 2

$$m = \frac{I_x}{I_y}, \quad m > 0.5 : 1 \text{ 방향 슬래브}$$

$$m \leq 0.5 : 2 \text{ 방향 슬래브}$$

(4) 2

[해 설]

(1)

3.3.3

(2)

(3.2)

$$M = \cdot W_u \cdot I_x^2 \quad (3.13)$$

$$M = \frac{2}{3} \cdot \cdot W_u \cdot I_x^2 \quad (3.14)$$



[3.6(a)]

$$m = \frac{I_x}{I_y} < 0.5$$

[3.6(b)]

$$I_x \cdot I_y \cdot$$

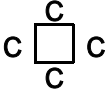
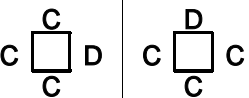
[3.2] 2

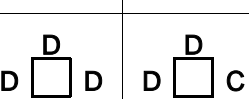
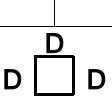
불연속 단수 지 지 조 건	방향	단 변						장변
	<i>m</i>	1.0	0.9	0.8	0.7	0.6	0.5	<i>m</i>
	C	0.033	0.040	0.048	0.055	0.063	0.083	0.033
		0.025	0.030	0.036	0.041	0.047	0.062	0.025
	C	0.041	0.048	0.05	0.062	0.069	0.085	0.041
	D	0.021	0.024	0.027	0.031	0.035	0.042	0.021
		0.031	0.036	0.041	0.047	0.052	0.064	0.031
	C	0.049	0.057	0.064	0.071	0.078	0.090	0.049
	D	0.025	0.028	0.032	0.036	0.039	0.045	0.025
		0.037	0.043	0.048	0.054	0.059	0.068	0.037
	C	0.058	0.066	0.074	0.082	0.090	0.098	0.058
	D	0.029	0.033	0.037	0.041	0.045	0.049	0.029
		0.044	0.050	0.056	0.062	0.068	0.074	0.044
	D	0.033	0.038	0.043	0.047	0.053	0.055	0.033
		0.050	0.057	0.064	0.072	0.080	0.083	0.050

[]

C : , D : , $m = \frac{I_x}{I_y}$, $m' : m$

2

m

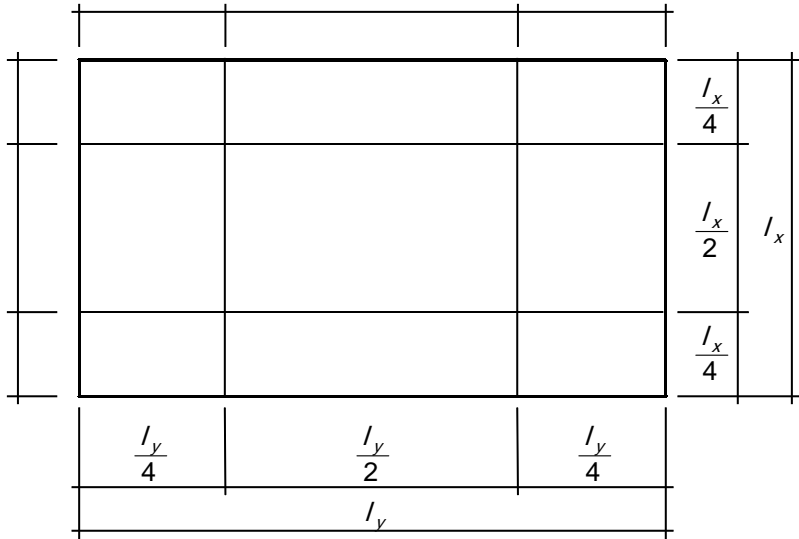

(a) 2

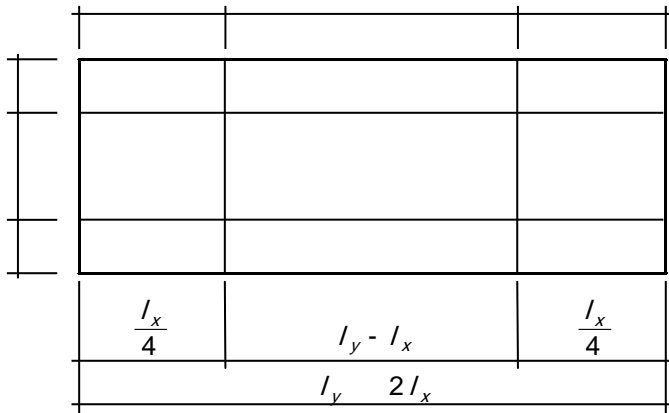

(b) 1

[3.6]

마. 정착 및 이음

(1) 「
」 8 .

[해 설]

(1) “ ” 4.4 . 가
가

바. 슬래브의 개구부 보강

(1)

[해 설]

(1) , , .

사. 배치 계획

(1) , .

[해 설]

(1) .

50 mm [3.7],
가 10 mm

가 [3.8]

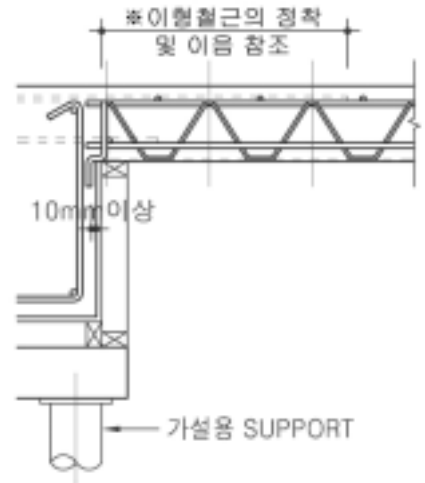
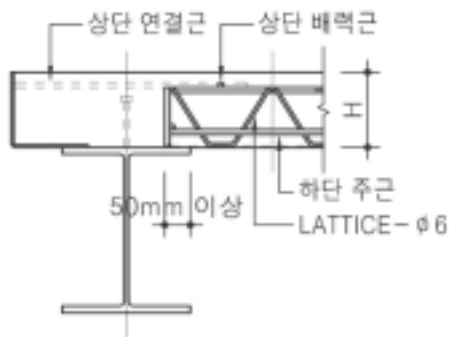

< 3.7 >

(1)

< 3.8 >

(2)

가

30 mm

가

600 mm

[3.9]

50 mm

(Fleshing,

)

[3.10

], 50 mm

가

[3.11]

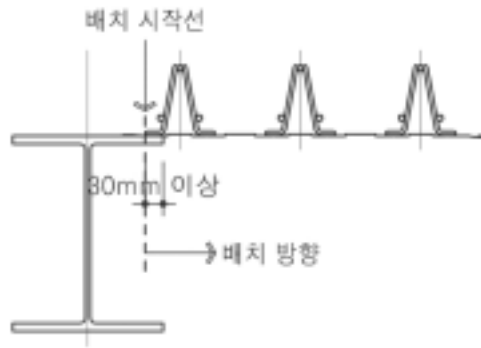

< 3.9> (1)



< 3.10> (2)

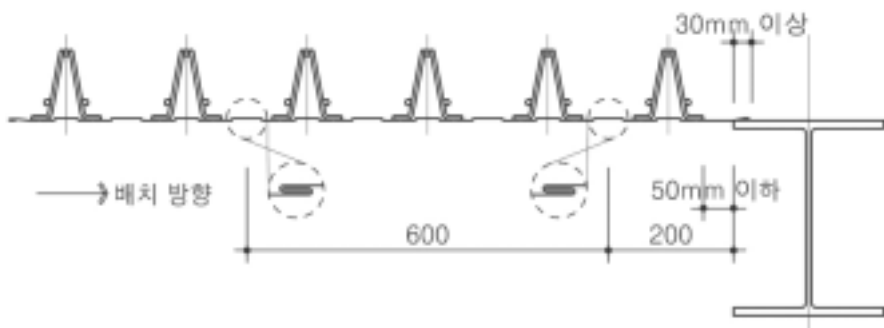

< 3.11> (3)

8. 시 공

가. 일반사항

(1)	
(2)	

[해 설]

(2)

나. 시공 계획 및 관리

(1) 일반 사항

(1)	
(2)	

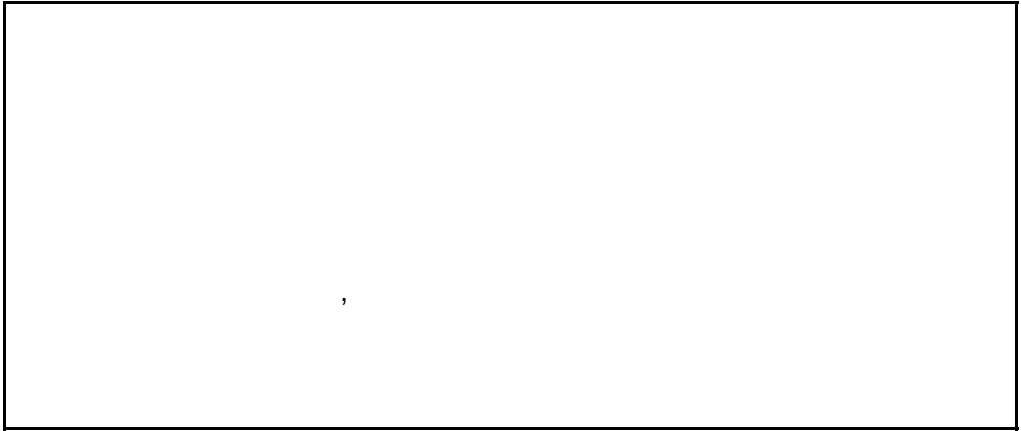

(2) 부재 제작 계획

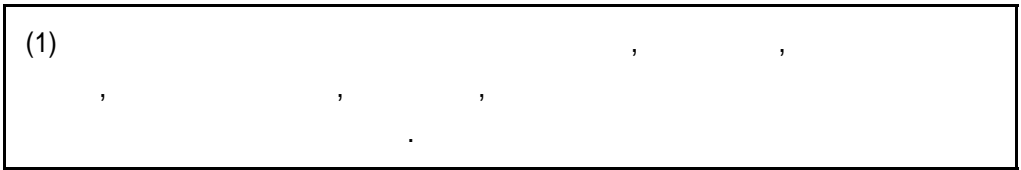

(3) 공정 계획

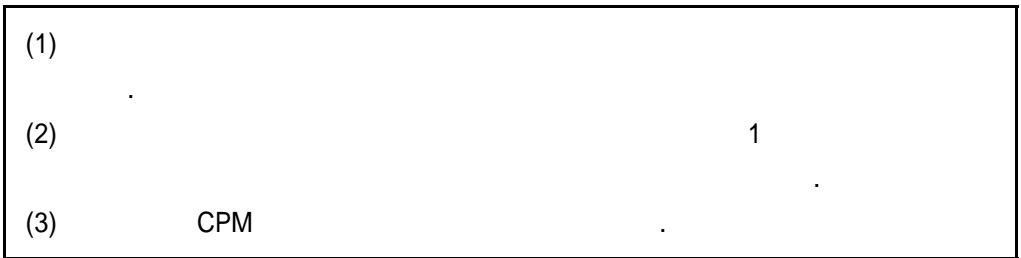

시공계획 수립	◆ -	◆
반입	◆ ◆	◆ :
양중	◆ ◆ -	◆ :
설치	◆ - - 가 - - 가 - - - -	◆ : , (@300) : , (@300)
배근	◆ ◆) ◆ ◆	◆ : ◆ .
점검	◆ ◆ ◆ ◆	
콘크리트 타설	◆ ◆ ◆ ◆	

[4.1]

다. 트러스테크의 주문 및 생산

(1) 주문

(1)	TYPE, , ,
-----	-----------

(2) 생산

(1)	.
(2)	, , , , 2
(3)	.

[해 설]

(1)

1 , ,
가 .

(2)

. , ,
가
() 가
.

(3) 품질 검사 및 관리

(1)	
(2)	,
(3)	2
(4)	

[해 설]

(3)

2

(4) 저 장

(1)	,
(2)	

[해 설]

(1)

가,

()

3

가

가

2

4

가

(2)

(5) 출 하

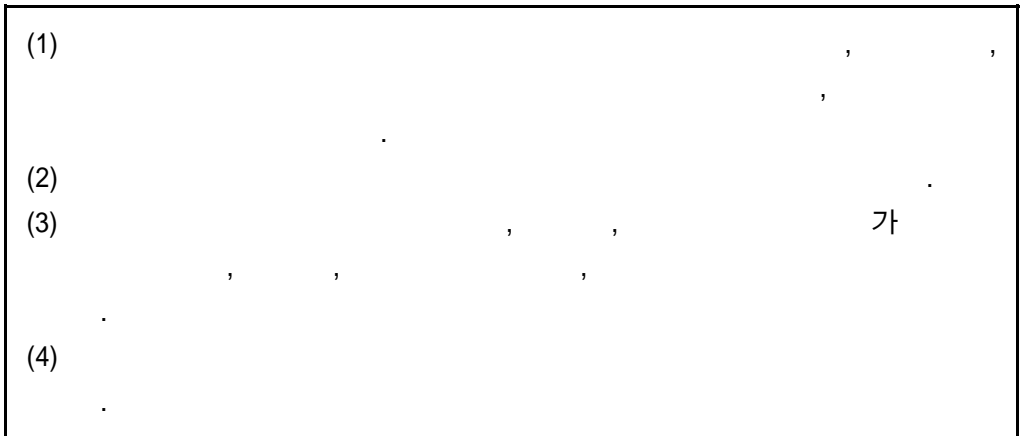

[해 설]

(2)

가

1

가 1

가

2

1

36

2

4.2

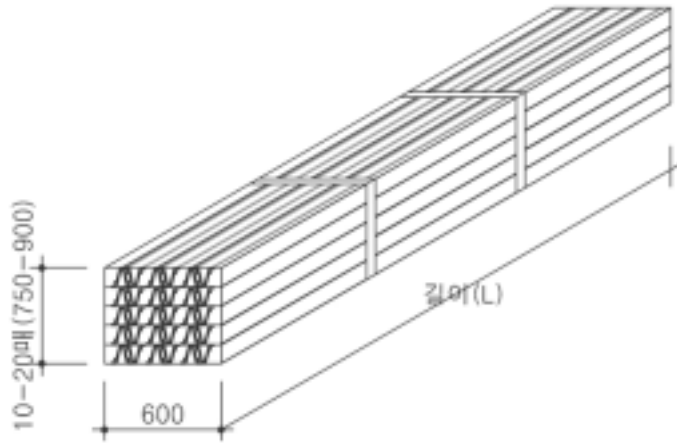

[4.2]

공 사 명	
공 구	
포 장 번 호	
트러스데크 TYPE	
수 량	

[4.3]

(6) 운 송

- (1) , , 가
- (2) , ,
- (3) .
- (4) .
- (5) .

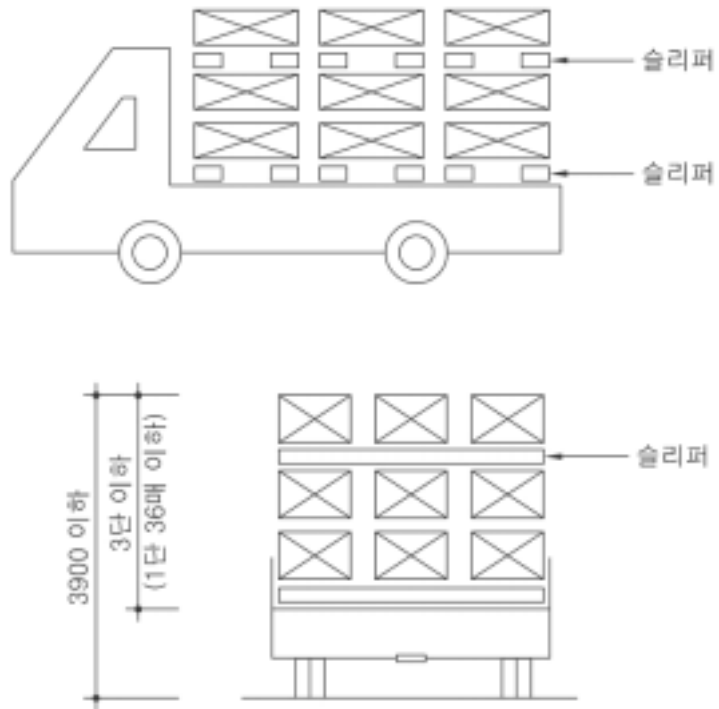

[4.4]

라. 트러스테크의 현장 반입 및 야적

(1) 일반 사항

(2) , , , .

(2) 반 입

(1) .
(2) .
(3) 가 , .
(4) , .
. .

마. 검 수

(1) 품질 검수

(1)	,	,	,
(2)	,	,	,
(3)	,	,	,
(4)	,	,	,
(5)	TYPE	30	1
(6)		1	

[해 설]

(2)

: , , ,
 : , , , , ,
 : (, ,),
 (), ()

(3)

: 4.1
 가

: 가

[4.1]

검 수 내 용	검 수 방 법	비 고
		• 30 1
’ ’	’	•
		• 2
		•
		• 4%
’ ’ ’ ’		• 2

:

’ 가 가

:

3

:

’ 4%

:

’ ’ ’

’

2

’

가

바. 야적 관리

- (1) ,
- (2) , 가
- (3) .



[4.5]

(1) 양중 장비의 선정

(1) 가 , 가 , 가 . 가

(2) 양중 사이클

(1) 1 1 .

(3) 양중 준비

(1) 가 가
 가 .
 (2) . ,
 (3) 가 .
 (4) .

(4) 양중 방법

(1) , , 가

(2) 가

[해 설]

(1) 가 가

(2) 가 가

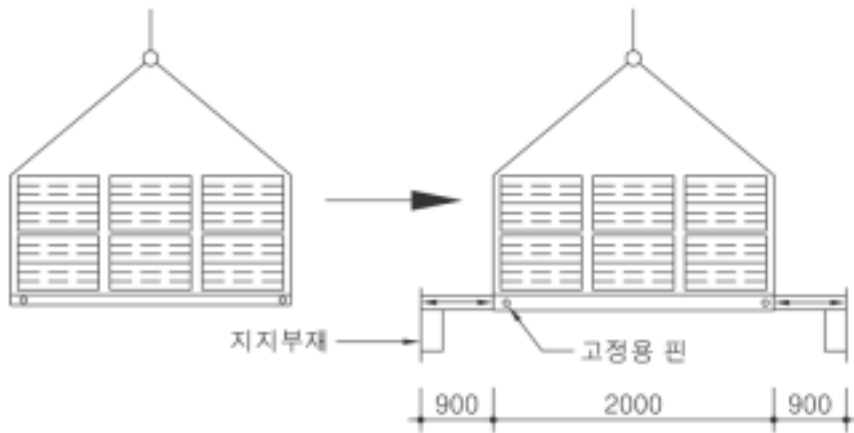

[4.6]

나. 설 치

(1) 일반 사항

(1)	
(2)	

[해 설]

(2)

(2) 트러스테크의 결침

(1)	
(2)	가
(3)	3.7, 3.8, 3.9, 3.10, 3.11 4.6.3, 4.6.4, 4.6.5

(3) 철골조의 경우

(1)		1
(2)	가	
(3)	2	1

[해 설]

(1) 1 가

- 가
- (2) 가
- (3) 가

(4) 철근 콘크리트조의 경우

- (1) 1
- (2) 가 10 mm
- (3) 가

[해 설]

- (1) , 1
1 가
- (2) 10 mm
- (3) 1 가 ,
300 mm (1)
- (4)

(5) 철골·철근콘크리트의 경우

(1)	·	4.6.3	4.6.4
-----	---	-------	-------

다. 트러스테크의 가공

(1)	가	,
-----	---	---

[해 설]

(1) ,
·
(Hand Saw Skill Saw)
·
가
,
가
,
가
,
가
,
가

라. 기타 부자재 및 배력 철근 배근

(1) 부자재의 설치

(1)	,	,
-----	---	---

[해 설]

(1) ,

가

가

(2) 슬래브 개구부 보강

(1)	
(2)	()
(3)	
(4)	가

[해 설]

- (1) 가 가
(가) 가
()
가 가
- (3)

(3) 배근 및 설치 완료 검사

(1)	,	.
(2)	.	.
(3)	.	.

10. 콘크리트 타설

가. 일반 사항

(1)			
(2)	5	.	.
	가	.	.

나. 콘크리트 타설 준비

(1)	.	.
(2)	.	.

[해 설]

- (1) 가 가
- (2)

다. 콘크리트 타설시 주의 사항

1.	가	가
2.	가	가

[해 설]

(2)

가

부록. I 「콘크리트 구조 설계 기준」
관련 규정

제 1 장 설계 일반

1.1 적용 범위

(2)

제 2 장 재료

2.2.3 강재

(3) , , KS D 3504() , KS D 3552() KS D 7017()

(4) , f_y 가 4,000 kgf/cm²
 f_y 0.0035

제 3 장 설계 하중 및 하중 조합

3.4 구조 해석 일반

3.4.1 해석 방법

(1) 3.4.2

3.4.4 3.4.7 가

(2)

(3) (4)

(3) 1 3.4.1(4)

2

2 가 20% 가

3

가

(4) 3.4.1(3)

1

(가)

가 $\frac{u I_n^2}{11}$

가 $\frac{u I_n^2}{14}$

() $\frac{u I_n^2}{16}$

(가)

2 $\frac{u I_n^2}{9}$

3 $\frac{u I_n^2}{10}$

() $\frac{u I_n^2}{11}$

() $3m$

가 8 $\frac{u I_n^2}{12}$

() 가

..... $\frac{u I_n^2}{24}$

가 $\frac{u I_n^2}{16}$

(가) $1.15 \frac{u l_n}{2}$

() (가) $\frac{u l_n}{2}$

3.4.5 경간

(1)

(2)

(3) $3 m$

제 4 장 사용성 및 내구성

4.2 균열

4.2.4 균열의 검토

(1)

60%

건조 환경	가
습윤 환경	
부식성 환경	1)
	2)

	(가, ,)
고부식성 환경	1) 2)

[4.2.1]

[4.2.2] (mm)

강 재 의 종 류		강 재 의 부 식 에 대 한 환 경 조 건			
		건조 환경	습윤 환경	부식성 환경	고부식성 환경
철근	건 물	0.4 mm	0.3 mm	0.004 t _c	0.0035 t _c
	기 타 구조 물	0.006 t _c	0.005 t _c		
프리스트레싱 긴장재		0.005 t _c	0.004 t _c	-	-

t_c

(mm)

(2)

가 3,000 kgf/cm²

(4.2.1)

4.2.2

가

$$= 1.08 f_s \sqrt[3]{d_c A} \times 10^{-5} \text{ (mm)}$$

f_s

f_y

60%

1.2,

1.35

(3)

가

(4)

가

5.7

가

4.3 처짐

4.3.1 1방향 구조

(1)

4.3.1

[4.3.1]

부재	최 소 두 계 , (h)			
	단 순 지 지	1 단 연 속	양 단 연 속	캔 틸 레 버
1 방 향 슬 래 브	$\frac{l}{20}$	$\frac{l}{24}$	$\frac{l}{28}$	$\frac{l}{10}$
보 리 브 가 있 는 1 방 향 슬 래 브	$\frac{l}{16}$	$\frac{l}{18.5}$	$\frac{l}{21}$	$\frac{l}{8}$

$$(w_c = 2.3 \text{ tf/m}^3)$$

$$4,000 \text{ kgf/cm}^2$$

$$1.5 \sim 2.0 \text{ tf/m}^3$$

$$h \quad (1.65 - 0.31 w_c) \quad , \quad 1.09$$

$$f_y \text{ 가 } 4,000 \text{ kgf/cm}^2 \quad h \quad \left(0.43 + \frac{f_y}{7,000} \right)$$

(5)

가

$$= \frac{1}{1 + 50} \quad (4.3.4)$$

- 5 2.0
- 12 1.4
- 6 1.2
- 3 1.0

(6) (4.3.1) I_e (4.3.4)

4.3.3

[4.3.3]

부 재 의 형 태	고 려 해 야 할 처 짐	처 짐 한 계
과도한 처짐에 의해 손상되기 쉬운 비구조 요소를 지지 또는 부착하지 않는 평지붕구조	L	$\frac{I}{180}$ 1)
과도한 처짐에 의해 손상되기 쉬운 비구조 요소를 지지 또는 부착하지 않은 바닥구조	L	$\frac{I}{360}$
과도한 처짐에 의해 손상되기 쉬운 비구조 요소를 지지 또는 부착한 지붕 또는 바닥구조	가 (가	$\frac{I}{480}$ 3)
과도한 처짐에 의해 손상될 염려가 없는 비구조 요소를 지지 또는 부착한 지붕 또는 바닥구조) 2)	$\frac{I}{240}$ 4)

1)

가

2)

4.3.1(5)

4.3.3.(2)

3)

가

4)

제 5 장 철근 상세

5.4 최소 피복 두께

5.4.1 현장치기 콘크리트

(1)

..... 8 cm

(2)

D29 6 cm

D25 5 cm

D16 , 16 mm 4 cm

(3)

(가) D35 4 cm

() D35 2 cm

5.7 수축 · 온도 철근

5.7.1 일반사항

(1)

1

(2)

5.7.2

5.7.3

(3) 5.7.2

가

5.7.2 1방향 철근 콘크리트 슬래브

(1)

0.0014

가 4,000 kgf/cm²

..... 0.0020

0.0035

가

4,000 kgf/cm²

..... 0.0020 × $\frac{4,000}{f_y}$

(2) · 5 , 40 cm

(3) · f_y

6 장 휨 및 압축

6.3 휨 부재 설계의 제한 사항

6.3.2 휨 부재의 최소 철근량

(1)

6.3.2(2) A_s (6.3.1)

(6.3.2)

$$A_{s,min} = \frac{0.80\sqrt{f_{ck}}}{f_y} b_w d \quad (6.3.1)$$

$$A_{s,min} = \frac{14}{f_y} b_w d \quad (6.3.2)$$

(3) 1/3

6.3.2(1) 6.3.2(20)

(4) 가

5.7

3 40 cm

6.3.3 보 및 1방향 슬래브의 휨 철근 배근

(1)

1

6.3.3

(2) 2

10.6

(3) 6.3.3(4)

(4) f_y 가 $3,000 \text{ kgf/cm}^2$
 , (4.2.1)
 4.2.2 가 .

제 7 장 전단과 비틀림

7.10 슬래브와 기초판에 대한 전단 설계

7.10.1 전단 설계 단면

(1) (2) (3)
 (2) ,
 d
 7.2 7.3 .
 (3) 2
 7.10.2 7.10.4 .
 b_0
 $d/2$ 가 .

제 8 장 정착 및 이음

8.2 철근의 정착

8.2.1 정착 일반

(1) , , , .
 (2) $\sqrt{f_{ck}}$ 26.5 kgf/cm^2 .

8.2.2 인장 이형 철근 및 이형 철선의 정착

(1) l_d 8.2.2(2)

$$l_{db} \quad 8.2.2(3) \quad (8.2.2)$$

8.2.2(5)

$$l_d \quad 30 \text{ cm}$$

$$(2) \quad l_{db} \quad (8.2.1)$$

$$l_{db} = \frac{0.152 d_b f_y}{\sqrt{f_{ck}}}$$

(3) 8.2.1

[8.2.1]

조건	철근 지름	D 19 이하의 철근과 이형철선	D22 이상의 철근
정착되거나 이어지는 철근의 순간격이 d_b 이상이고 피복 두께도 d_b 이상이면서 l_d 전 구간에 설계 기준에서 규정된 최소 철근량 이상의 스티럽 또는 띠철근을 배근한 경우 또는 정착되거나 이어지는 철근의 순간격이 $2d_b$ 이상이고 피복 두께가 d_b 이상인 경우		. .	1.25 . .
기	타	1.5 . .	1.88 . .

8.2.1

- (가) (30 cm) 1.3
- () 1.0
- (가) 가 $3d_b$ $6d_b$ 1.5
- () 1.2

- () 1.0
- :
- (가) f_{sp} 가 1.3
- () f_{sp} 가 $1.8 \frac{\sqrt{f_{ck}}}{f_{sp}}$ 1.0
- () 1.0

- 가 1.7
- (4) 8.2.2(2) 8.2.2(3) 8.2.1
- (8.2.2)

$$l_d = \frac{0.285 d_b f_y}{\sqrt{f_{ck}}}$$

$$(8.2.2) \quad \frac{c + K_{tr}}{d_b} \quad 2.5 \quad (8.2.2)$$

, c K_{tr}

- :
- (가) D19 0.8
- () D22 1.0

c :

1/2 cm

K_{tr} :

$$K_{tr} = \frac{A_{tr} f_{yt}}{107 s n}$$

$K_{tr} = 0$

(5)

(AS/ AS)

f_y

8.6.2 인장 이형 철근 및 이형 철선의 이음

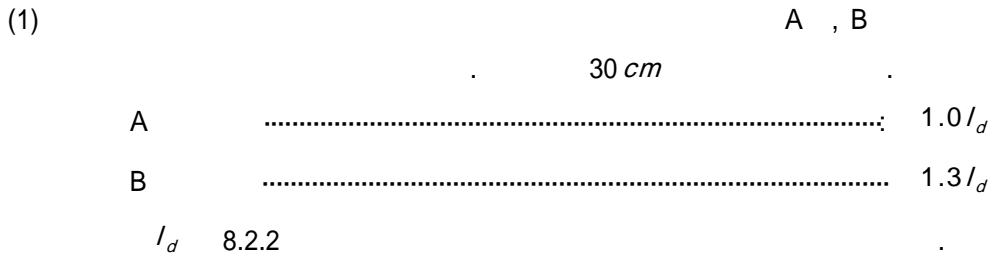

8.2.2(5)

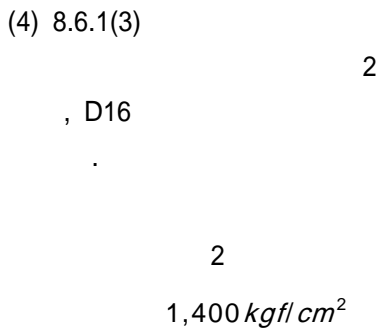
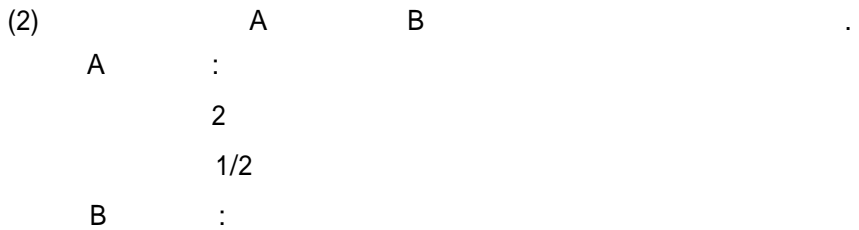

f_y

(5) I_d 8.6.1(3) f_y
75 cm

제 10장 슬래브

10.1 일반 사항

10.1.1 적용 범위

(1) 10.2 1 2

(2) 2

(5) 4.3

10.2. 1방향 슬래브

10.2.1 설계 일반

(1) 1 6

(2) 4 2 가 2
1

6

3.4.5

10.2.2 철근 콘크리트 보와 일체로 된 연속 슬래브

(1) 3.4.1

3.4.5

1/2

3.0 m

l_n

(2)

[해 설]

10.2.1 적용 범위

1

2

4

가

2

4.3.1 1

4.3.1

4.3.3

가

가

4.3.3

10.2.2 1방향 슬래브의 실용 해법

(1) 1

1) 2

2)

2

가

20%

가

3)

4)

3

(2)

1

1)

(

$W_u l_n^2$

)

2

(

3 m

)

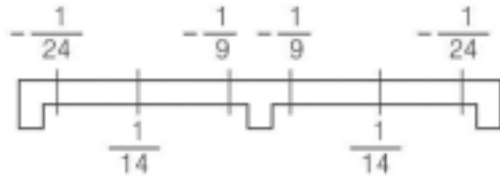

2 (3 m)

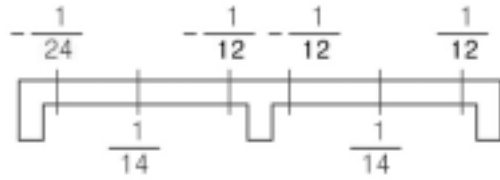

3 (3 m)

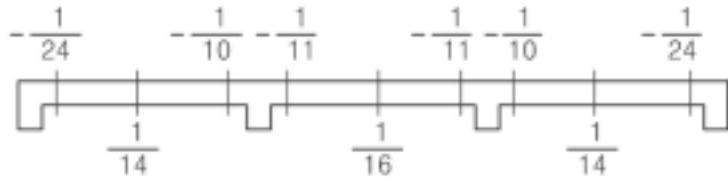

3 (3 m)

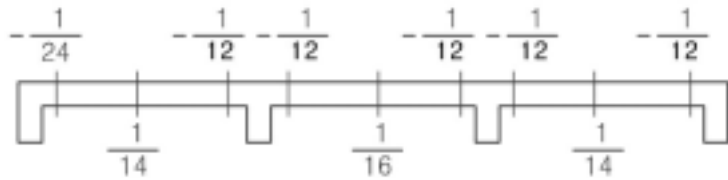

2)

d

..... $1.15 \frac{W_u I_n}{2}$

..... $\frac{W_u I_n}{2}$

10.2.3 1방향 슬래브의 구조 제한

(1) (10.2.3)

- ◆ : : .
- ◆ : : 3 , 40 cm
- ◆ : : .
- ◆ 5.7.2 :
- .
- 0.0014 .
- 가 ; 0.0020
- 0.0035 가
- 4,000 kgf/cm² ; $0.0020 \times \frac{4000}{f_y}$
- 5 , 40 cm

(2)

- 1 4.3.1 , 10 cm
- 가
- 2 , 30 cm
- 1
- 5.7.2 .
- 가

3.4.8(3)

■ 이형 철근의 정착 및 이음

[, 2000 ,]

1. 인장 이형 철근의 정착

(1)

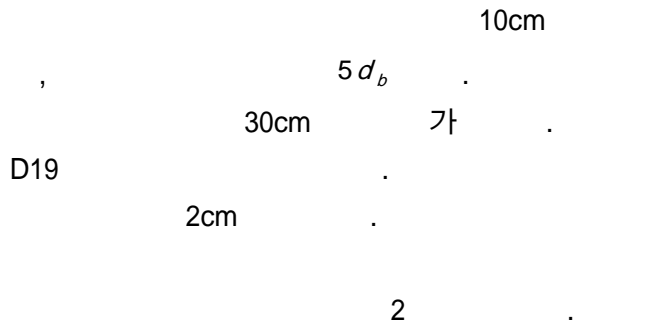

$$l_d = \frac{0.285 d_b f_y}{\sqrt{f_{ck}}} \cdot \left(\frac{c + K_{tr}}{d_b} \right) \quad [2]$$

$$, \quad = \quad = 1.0, \quad = 0.8, \quad K_{tr} = 0$$

$$l_d = \frac{0.285 d_b f_y}{\sqrt{f_{ck}}} \cdot \frac{0.8}{\left(\frac{c}{d_b} \right)} = \frac{0.228 f_y}{\sqrt{f_{ck}}} \cdot \frac{d_b}{\left(\frac{c}{d_b} \right)}$$

2cm ,

$$D10 \quad \frac{c}{d_b} = \frac{(2.0 + 0.5)}{1.0} = 2.50$$

$$D13 \quad \frac{c}{d_b} = \frac{(2.0 + 0.5)}{1.3} = 1.92$$

$$D16 \quad \frac{c}{d_b} = \frac{(2.0 + 0.5)}{1.6} = 1.75$$

$$D19 \quad \frac{c}{d_b} = \frac{(2.0 + 0.5)}{1.9} = 1.55$$

1

$$l_b = \frac{0.152 d_b f_y}{\sqrt{f_{ck}}} \quad [1]$$

$$f_y = 4,000 \text{ kgf/cm}^2$$

f_{ck} (kgf/cm^2)	식2에 의한 정착 길이 (cm)								식1
	D10		D13		D16		D19		D19이하
	$\frac{l_d}{d_b}$	l_d	$\frac{l_d}{d_b}$	l_d	$\frac{l_d}{d_b}$	l_d	$\frac{l_d}{d_b}$	l_d	$\frac{l_d}{d_b}$
210	25.17	30	32.78	43	35.96	58	40.60	78	41.96
240	23.55	30	30.66	40	33.64	54	37.98	73	39.25
270	22.20	30	28.91	38	31.72	51	35.81	68	37.00
300	21.06	30	27.42	36	30.09	49	33.97	65	35.10
350	19.50	30	25.39	33	27.86	45	31.45	60	32.50
400	18.24	30	23.75	31	26.06	42	29.42	56	30.40
450	17.20	30	22.39	30	24.57	40	27.74	53	28.66
500	16.31	30	21.24	30	23.31	38	26.31	50	27.19

(2)

1

$$D19 \quad l_d = \frac{0.152 d_b f_y}{\sqrt{f_{ck}}} \times$$

$$D22 \quad l_d = \frac{0.152 d_b f_y}{\sqrt{f_{ck}}} \times 1.25$$

$$f_y = 4,000 \text{ kgf/cm}^2$$

f_{ck} (kgf/cm^2)	배근위치	D19이하					D22이상					
		$\frac{l_d}{d_b}$	l_d (cm)				$\frac{l_d}{d_b}$	l_d (cm)				
			D10	D13	D16	D19		D22	D25	D29	D32	D35
210		41.96	42	55	68	80	52.44	116	132	153	168	184
		54.55	55	55	71	104	68.17	150	171	198	219	239
240		39.25	40	51	63	75	49.06	108	123	143	157	172
		51.03	51	67	82	97	63.78	141	160	185	205	224
270		37.00	37	49	60	71	46.25	102	116	135	148	162
		48.10	49	63	77	92	60.13	133	151	175	193	211
300		35.10	36	46	57	67	43.88	97	110	128	141	154
		45.63	46	60	73	87	57.04	126	143	166	183	200
350		32.50	33	43	52	62	40.62	90	102	118	130	143
		42.25	43	55	68	81	52.81	117	132	154	169	185
400		30.40	31	40	49	58	38.00	84	95	111	122	133
		39.52	40	52	64	76	49.40	109	124	144	159	173
450		28.66	30	38	46	55	35.83	79	90	104	115	126
		37.18	38	49	90	71	46.58	103	117	136	150	163
500		27.19	30	36	44	52	33.99	75	85	99	109	119
		35.35	36	46	57	68	44.19	98	111	129	142	155

30cm

2. 압축 이형 철근의 정착

- (1) l_d l_{db}
- 20cm
- (2)

$$l_{db} = \frac{0.08 d_b f_y}{\sqrt{f_{ck}}} \quad 0.004 d_b f_y \quad [\quad 3 \quad]$$

(3)

$$f_y = 4,000 \text{ kgf/cm}^2$$

f_{ck} (kgf/cm^2)	$\frac{l_{db}}{d_b}$	l_{db} (cm)								
		D10	D13	D16	D19	D22	D25	D29	D32	D35
210	22.08	23	29	36	42	49	56	64	71	78
240	20.66	21	27	34	40	46	52	60	67	73
270	19.47	20	26	30	37	43	49	57	63	69
300	18.48	20	24	30	36	41	46	54	60	65
350	17.10	20	23	28	33	38	43	50	55	60
400	16.00	20	21	26	31	36	40	47	52	56
450	16.00	20	21	26	31	36	40	47	52	56
500	16.00	20	21	26	31	36	40	47	52	56

(4)

6mm	10cm	0.75
10cm	D13	

3. 표준 갈고리를 갖는 인정 이형 철근의 정착

(1) 가 l_{dh}

$$l_{hb}$$

(2) $l_{dh} = 8d_b$ 15cm

(3)

$$l_{hb} = \frac{305 d_b}{\sqrt{f_{ck}}}$$

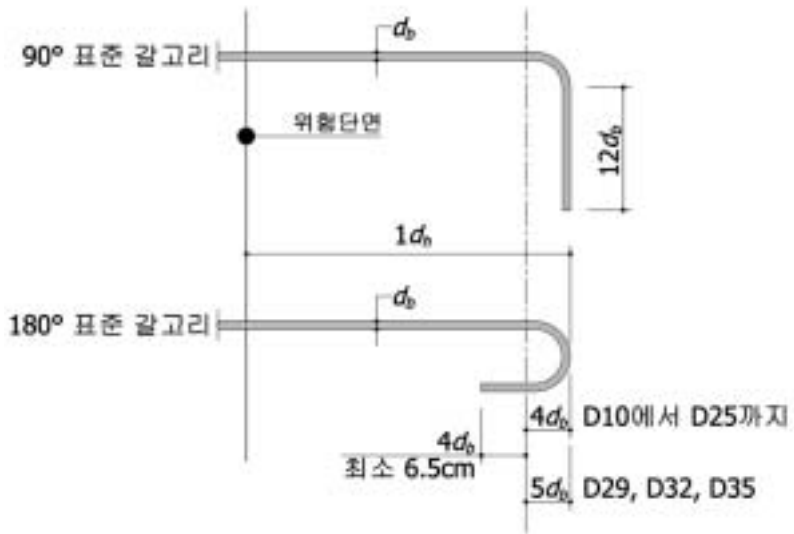

$$f_y = 4,000 \text{ kgf/cm}^2$$

f_{ck} (kgf/cm^2)	$\frac{l_{hb}}{d_b}$	식4에 의한 기본 정착 길이								
		l_{hb} (cm)								
		D10	D13	D16	D19	D22	D25	D29	D32	D35
210	21.05	22	28	34	40	47	53	61	68	74
240	19.69	20	26	32	38	44	50	58	63	69
270	18.56	19	25	30	36	41	47	54	60	65
300	17.61	18	23	29	34	39	44	52	57	62
350	16.30	17	22	27	31	36	41	48	53	58
400	15.25	16	20	25	29	34	39	45	49	54
450	14.38	15	19	23	28	32	36	42	46	51
500	13.64	14	18	22	26	30	35	40	44	48

(4)

	6.5cm , 5.0cm (90°)	0.7
$3d_b$		0.8

(5) 가
가 1.0

$$f_y = 4,000 \text{ kgf/cm}^2$$

f_{ck} (kgf/cm^2)	$\frac{l_{hb}}{d_b}$	$l_{hb} = 1.0 l_{hb} \text{ (cm)}$								
		D10	D13	D16	D19	D22	D25	D29	D32	D35
210	21.05	22	28	34	40	47	53	61	68	74
240	19.69	20	26	32	38	44	50	58	63	69
270	18.56	19	25	30	36	41	47	54	60	65
300	17.61	18	23	29	34	39	44	52	57	62
350	16.30	17	22	27	31	36	41	48	53	58
400	15.25	16	20	25	29	34	39	45	49	54
450	14.38	15	19	23	28	32	36	42	46	51
500	13.64	15	18	22	26	30	35	40	44	48

가 0.7

$$f_y = 4,000 \text{ kgf/cm}^2$$

f_{ck} (kgf/cm^2)	$\frac{l_{hb}}{d_b}$	$l_{hb} = 0.7 l_{hb} \text{ (cm)}$								
		D10	D13	D16	D19	D22	D25	D29	D32	D35
210	14.74	15	20	24	28	33	37	43	48	52
240	13.78	15	18	22	27	31	35	40	45	49
270	12.99	15	17	21	25	29	33	38	42	46
300	12.33	15	16	20	24	28	31	36	40	44
350	11.41	15	15	19	22	26	29	34	37	40
400	10.68	15	15	18	21	24	27	31	35	38
450	10.07	15	15	17	20	23	26	30	33	36
500	9.55	15	15	16	19	21	24	28	31	34

(6)

4. 이형 철근의 이음

(1)

가

D38

D29

1/5 , 15cm

, 가

(2)

A

B

A (1.0 l_d)

A

$f_y = 4,000 \text{ kgf/cm}^2$

f_{ck} (kgf/cm^2)	식2에 의한 정착 길이 (cm)								식1
	D10		D13		D16		D19		D19이하
	$\frac{l_d}{d_b}$	l_d	$\frac{l_d}{d_b}$	l_d	$\frac{l_d}{d_b}$	l_d	$\frac{l_d}{d_b}$	l_d	$\frac{l_d}{d_b}$
210	25.17	30	32.78	43	35.96	58	40.60	78	41.96
240	23.55	30	30.66	40	33.64	54	37.98	73	39.25
270	22.20	30	28.91	38	31.72	51	35.81	68	37.00
300	21.06	30	27.42	36	30.09	49	33.97	65	35.10
350	19.50	30	25.39	33	27.86	45	31.45	60	32.50
400	18.24	30	23.75	31	26.06	42	29.42	56	30.40
450	17.20	30	22.39	30	24.57	40	27.74	53	28.66
500	16.31	30	21.24	30	23.31	38	26.31	50	27.19

A

$$f_y = 4,000 \text{ kgf/cm}^2$$

f_{ck} (kgf/cm^2)	배근위치	D19이하					D22이상					
		$\frac{I_d}{d_b}$	I_d (cm)				$\frac{I_d}{d_b}$	I_d (cm)				
			D10	D13	D16	D19		D22	D25	D29	D32	D35
210		41.96	42	55	68	80	52.44	116	132	153	168	184
		54.55	55	55	71	104	68.17	150	171	198	219	239
240		39.25	40	51	63	75	49.06	108	123	143	157	172
		51.03	51	67	82	97	63.78	141	160	185	205	224
270		37.00	37	49	60	71	46.25	102	116	135	148	162
		48.10	49	63	77	92	60.13	133	151	175	193	211
300		35.10	36	46	57	67	43.88	97	110	128	141	154
		45.63	46	60	73	87	57.04	126	143	166	183	200
350		32.50	33	43	52	62	40.62	90	102	118	130	143
		42.25	43	55	68	81	52.81	117	132	154	169	185
400		30.40	31	40	49	58	38.00	84	95	111	122	133
		39.52	40	52	64	76	49.40	109	124	144	159	173
450		28.66	30	38	46	55	35.83	79	90	104	115	126
		37.18	38	49	90	71	46.58	103	117	136	150	163
500		27.19	30	36	44	52	33.99	75	85	99	109	119
		35.35	36	46	57	68	44.19	98	111	129	142	155

30cm

B (1.3 l_d)

B

$$f_y = 4,000 \text{ kgf/cm}^2$$

f_{ck} (kgf/cm^2)	식2에 의한 정착 길이 (cm)								식1
	D10		D13		D16		D19		D19이하
	$\frac{l_d}{d_b}$	l_d	$\frac{l_d}{d_b}$	l_d	$\frac{l_d}{d_b}$	l_d	$\frac{l_d}{d_b}$	l_d	$\frac{l_d}{d_b}$
210	32.72	39	42.61	56	46.75	75	52.78	101	54.55
240	30.62	39	39.86	52	43.73	70	49.37	94	51.03
270	28.86	39	37.58	49	41.24	66	46.55	89	48.10
300	27.38	39	35.65	47	39.12	63	44.16	84	45.63
350	25.35	39	33.01	43	36.22	58	40.89	78	42.25
400	23.71	39	30.88	41	33.88	55	38.25	73	39.52
450	22.36	39	29.11	39	31.94	52	36.06	69	37.26
500	21.20	39	27.61	39	30.30	49	34.20	65	35.35

A

$$f_y = 4,000 \text{ kgf/cm}^2$$

f_{ck} (kgf/cm^2)	배근위치	D19이하					D22이상					
		$\frac{l_d}{d_b}$	l_d (cm)				$\frac{l_d}{d_b}$	l_d (cm)				
			D10	D13	D16	D19		D22	D25	D29	D32	D35
210		54.55	55	71	88	104	68.17	150	171	198	219	239
		70.92	71	93	114	135	88.62	195	222	257	284	311
240		51.03	51	67	82	97	63.78	141	160	185	205	224
		66.34	67	87	107	126	82.91	183	208	241	265	291
270		48.10	49	63	77	92	60.13	133	151	175	193	211
		62.53	63	82	100	119	78.17	172	196	227	251	274
300		45.63	46	60	73	87	57.04	126	143	166	183	200
		59.32	60	78	95	113	74.15	164	186	215	238	260

350		42.25	43	55	68	81	52.81	117	132	153	169	185
		54.93	55	72	88	105	68.65	151	172	200	220	241
400		39.52	40	52	64	76	49.40	109	124	144	159	173
		52.38	52	67	83	98	64.22	142	161	187	206	225
450		37.18	39	49	60	71	46.58	103	117	136	153	163
		48.33	49	63	78	92	60.55	134	152	176	194	212
500		35.35	39	46	57	68	44.19	98	111	129	142	155
		45.96	46	60	74	88	57.45	127	144	167	184	202

30cm

(3)

$$f_y = 4,000 \text{ kgf/cm}^2$$

f_{ck} (kgf/cm^2)	$\frac{l_d}{d_b}$	l_d (cm)								
		D10	D13	D16	D19	D22	D25	D29	D32	D35
210	28.80									
240										
270										
300										
350		30	38	47	55	64	72	84	93	101
400										
450										
500										

부록 Ⅱ. 「구조용 용접 철망」
관련 규정

1. 일반 사항

(1)	KS D 3554	, KS D 3552()
(2)	,	,

[해 설]

(1) 1 () [: %]
178

분석방법	C	Si	Mn	P	S	N	Ceq*
	0.22	0.60	1.60	0.05	0.05	0.012	0.50
	0.24	0.65	1.70	0.055	0.055	0.013	0.52

$$Ceq = C + \frac{M_n}{6} + \frac{(C_r + V + M_o)}{5} + \frac{(C_u + N_i)}{15}$$

2. 제조 방법

(1)	가	가
(2)	6mm 16mm	,
(3)		
(4)	가	
(5)		가
(6)		

[해 설]

(1)

2 가 ,
 0.8
 f_r 1 .

$$f_r = \frac{k \times F_R \times \sin}{\times d_b \times c} \quad [1]$$

k :

d_b : (mm)

F_R : (mm²)

: (°)

: (°)

h : (3 , mm)

b : (mm)

c : (mm)

f_i : 1/3 (mm)

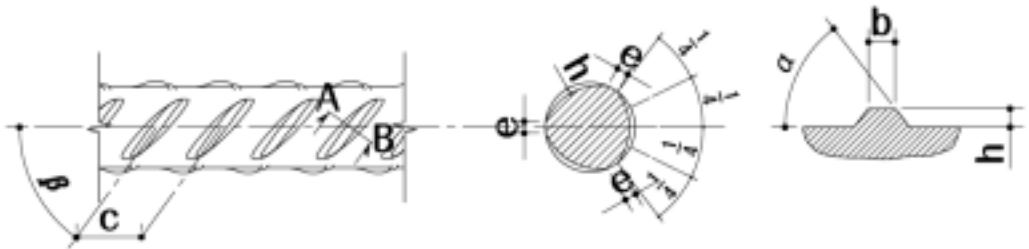

42

:

:

h :

b :

c :

f_i : 가 가

1/3

1

2

$$f_r = \frac{(\times d_b - f_i)[h + 2(h_{1/4} + h_{3/4})]}{6 \times \times d_b \times c} \quad [1]$$

f_i : 1

$h_{1/3}, h_{3/4} : 1 \quad 4$

2

179

공칭 지름 (mm)	상대 리브 면적 f_r
6	0.039
7, 8	0.045
9, 10	0.052
11 ~ 16	0.056

40° ~ 60° 가 , 3 3

공칭지름 d_b (mm)	리브높이 (mm)		리브폭 b (mm)	리브간격 c (mm)	최대값 f_i (mm)
	중간지점 (h)	1/4 지점 ($h_{1/3}, h_{3/4}$)			
6.0	0.40	0.32	$0.1 d_b$	5.0	3.8
7.0	0.46	0.37	$0.1 d_b$	5.0	4.4
8.0	0.55	0.44	$0.1 d_b$	6.0	5.0
9.0	0.75	0.60	$0.1 d_b$	7.0	5.7
10.0	0.75	0.60	$0.1 d_b$	7.0	6.3
11.0	0.97	0.77	$0.1 d_b$	8.4	6.9
12.0	0.97	0.77	$0.1 d_b$	8.4	7.6
1)	$\pm 15\%$				
2)	$0.2 d_b$				

2

2

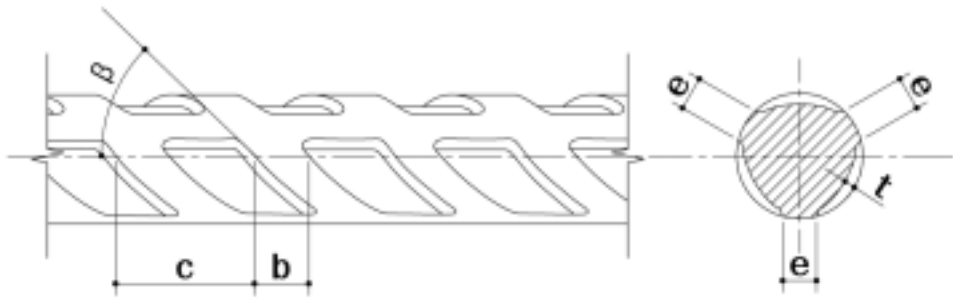

43

t :
 c :
 e : 1/3

$$f_p = \frac{k \times F_p \times \sin \beta}{d_b \times c} \quad [3]$$

F_p : (mm²)

k :

f_p 4 .

181

공칭 지름 (mm)	상대 리브 면적 f_p
6	0.008
7, 8	0.010
9, 10	0.013
11 ~ 16	0.014

40° ~ 60° 가 , 3

5 .

공칭지름 f_p	홈치수			
	홈깊이 t $\pm 0.05^{**}$	홈사이폭 b $\pm 0.5^{**}$	홈간격 c $\pm 0.5^{**}$	홈열사이 간격의 합 e (최대값)
6.0	0.20	2.00	6.0	3.8
7.0	0.25	2.50	7.0	4.4
8.0				5.0
9.0				5.7
10.0	0.35	2.75	8.0	6.3
11.0	0.40	3.00	9.0	6.9
12.0				7.5

4. 종류

(1)	
(2)	
(3)	(3) (5) 2

[해 설]

(1)

가

4

$$d_{min} \geq 0.6 d_{max} \quad [4]$$

$$d_{max} :$$

$$d_{min} :$$

5

$$0.7 \times d_T \leq d_L \leq 1.25 d_T \quad [5]$$

d_T : 가
 d_L : 1 가
 (3) , 3 4
 2 .

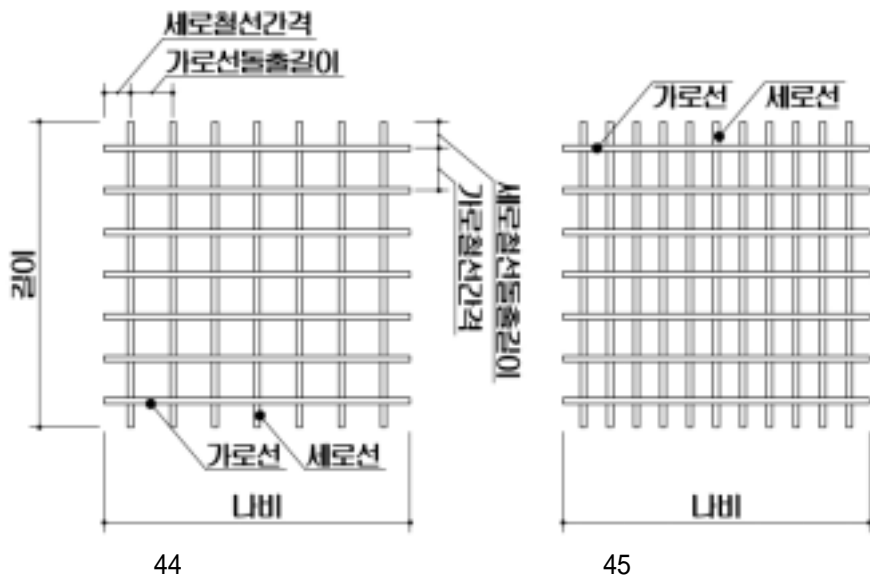

6. 치수 및 호칭

(1) ,

1 . ,

1 .

1 (: mm)

망 눈 치 수	50	75	100	150	200	250	300	400
허 용 차	± 6							

(2) ()

± 1% , KS A 0021()

(3) 가 , 2.4m ×
 4.8m 2 , 2.4m × 6.0m

(4) 2.4m 3m, 48m 72m .

철 망 의 길 이	나 비 허 용 차	길 이 허 용 차
6m	± 5mm	± 25mm
6m		-0.5%

(5) 가
 1/2 , ± 6mm . 25mm

(6) mm
 × 가 - × 가 - ×

[해 설]

(1) 1 .

(3) KS D 7017()
 2m × 4m 1m × 2m 2 .
 , 1 .
 , 가 , 가 ()
)
 1 가
 ± 5mm, 가 ± 1mm × (1 가 가)
 , ± 25mm -0.5% .

(4) , 2.4m , 6.0m 가
 가

가 $2.5 d_b$ 가
 $2.5 d_b$ 가
 가 가
 가 $5 d_b + 25mm$ 가
 (6) 가
 가 가

[]

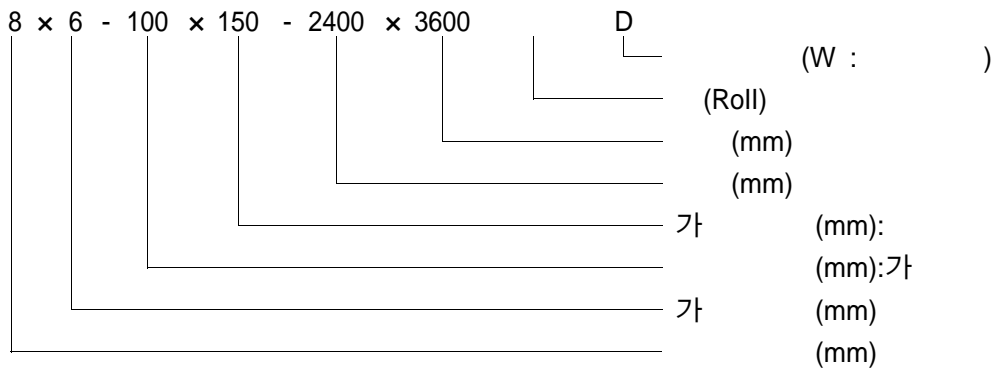
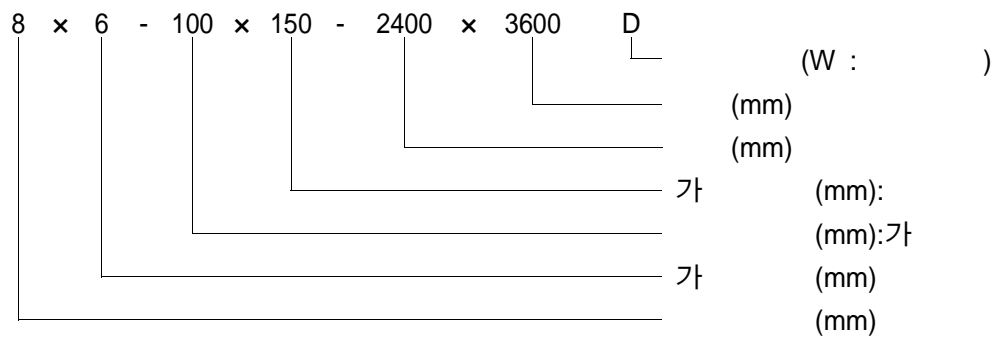

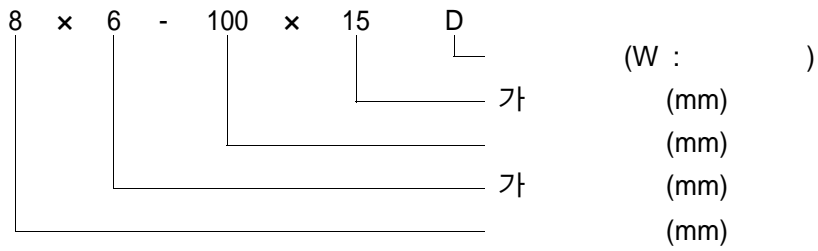
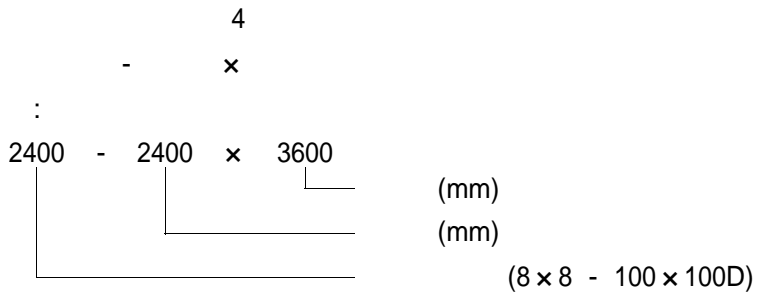

7. 선지름

(1)							3,
	6						
W	6	7	8	9	10	12	16
D	6	7	8	9	10	12	16

[해 설]

(1) 500mm 가 6

$$d_b = 12.74 \sqrt{\frac{G}{I}} \quad [6]$$

G : (g)
 I : (mm)

선지름	허용오차*
6.00	-0.10
6.00	-0.13

가 KS D 7017() 2.0~9.0mm
 가 16mm
 가 KS D
 7017() 가 2.0

8. 중량 및 단면적

(1)

호칭	공칭선지름 d_b (mm)	공칭단면적 A_w (mm ²)	단위중량 G	
			(kg/m)	허용차(%)
W6 D6	6	28.3	0.222	-8
W7 D7	7	38.5	0.302	-8
W8 D8	8	50.3	0.395	-8
W9 D9	9	63.6	0.499	-5
W10 D10	10	78.5	0.617	-5
W12 D12	12	113.1	0.888	-5
W16 D16	16	201.1	1.580	-5

[해 설]

(1) 7

$$A_w = \frac{1.274 G}{l} = \frac{d_b^2}{4} \quad [7]$$

A_w : (cm²)

가

7

호칭지름 (mm)		단면적 (cm^2)	단위 길이 중량 (kg/m)	1방향 1m당 단면적 (cm^2/m)				
				철선 간격 (mm)				
				100	150	200	300	400
W 6	D 6	0.283	0.222	2.830	1.887	1.415	0.943	0.708
W 7	D 7	0.385	0.302	3.850	2.567	1.925	1.283	0.963
W 8	D 8	0.503	0.395	5.030	3.353	2.515	1.677	1.258
W 9	D 9	0.636	0.499	6.360	4.240	3.180	2.120	1.590
W10	D10	0.785	0.617	7.850	5.233	3.925	2.617	1.963
W11	D11	0.950	0.746	9.500	6.333	4.750	3.167	2.375
W12	D12	1.131	0.888	11.310	7.540	5.655	3.770	2.828
W16	D16	2.011	1.580	20.110	13.407	10.056	6.703	5.028

8

호칭지름 (mm)		단위길이중량 (kg/m)	1방향 1m당 중량 (kg/m)				
			철선 간격 (mm)				
			100	150	200	300	400
W 6	D 6	0.222	2.22	1.48	1.11	0.74	0.56
W 7	D 7	0.302	3.02	2.01	1.51	1.01	0.76
W 8	D 8	0.395	3.95	2.63	1.97	1.32	0.99
W 9	D 9	0.499	4.99	3.33	2.50	1.66	1.25
W10	D10	0.617	6.17	4.11	3.08	2.06	1.54
W12	D12	0.888	8.88	5.92	4.44	2.96	2.22
W16	D16	1.580	15.80	10.53	7.90	5.27	3.95

9. 기계적 특성

(1)	가	550 kgf/cm ²
(550 N/mm ²)	, 0.5%	
	가 500 kgf/cm ² (550 N/mm ²)	
	, 0.35%	
	450 kgf/cm ² (450 N/mm ²)	
	(F _y)	
(2)	(d _b) 5 (5 d _b)	, 12%
(3)	가	
		150 kgf/cm ² (150 N/mm ²)
(4)	가	4
가	가 0.6	350 kgf (3.5 KN)
(5)	가	25mm
	180°	
(6) 5		5
(7)	가	, 가
	60° 가	
6 (6 d _b)		
(8)	f _y 가 4000 kgf/cm ²	0.0035

[해 설]

(1)

KS D 7017(

)) (

ISO 10544

(8)

가 f_y 가 $4,000 \text{ kgf/cm}^2$ f_y

0.0035

2.1.4(4))

부록 Ⅲ. 「한국 산업 규격」
관련 규정

Low Carbon Steel Wires

1. 적용 범위

() , , ()

- KS B 0801
- KS B 0802
- KS D 3553
- KS D 3554

2. 용어의 정의

- (1) : KS D 3554 가
- (6) () : 2
()
- (7) () : 2
()
- (16) :
- (17) : 가

3. 종류, 기호 및 선지름

4 , 2

3 ,

1 .

1 ,

mm

종 류	단면양	기 호	적 용 선 지름 1)	용 도 보 기
보 통 철 선		SWM-B	0.10 18.0	, 2), 3)
		SWM-F		
못 용 철 선		SWM-N	1.50 6.65	
어 닐 링 철 선		SWM-A	0.10 18.0	, 4)
		SWM-P	2.60 18.0	
용접철망용 철 선	리 브 선	SWM-R	4.0 19.0	, 5)
	인 텐 트 선	SWM-I		

4. 기계적 성질

4.1 SWM-B SWM-B 10.1 10.2 ,
1 .

4.2 SWM-F SWM-F 10.1 10.2 ,
1 .

4.8 SWM-I SWM-R SWM-I SWM-R

(1) SWM-I SWM-R , 0.2% 4) 5)

10.1 10.2 , 1 .

(2) SWM-I SWM-R 10.1 10.3 ,

1) 가 .

2) 가 , .

3) .

4) 0.2%

5) 5

5. 모양, 치수, 무게 및 그 허용차

5.1

(1)

(2)

2

2

(mm)

0.10	0.12	0.14	0.16	0.18	0.20	0.22	0.24	0.26	0.28	0.30	0.32	0.35
0.40	0.45	0.50	0.55	0.62	0.70	0.80	0.90	1.00	1.20	1.40	1.60	1.80
2.00	2.30	2.60	2.90	3.20	3.50	4.00	4.50	5.00	5.50	6.00	6.50	7.00
7.50	8.00	8.50	9.00	10.0	11.0	12.0	13.0	14.0	15.0	16.0	17.0	18.0

(3)

10.5

3

, SWM-N KS D 3553

3

: mm

선 지 림	S W M - B S W M - F	S W M - A	S W M - P
0.35이하	±0.01	±0.01	/
0.35초과 0.80이하	±0.02	±0.02	
0.80초과 2.00이하	±0.03	±0.04	
2.00초과 2.90이하	±0.04	±0.06	±0.06
2.90초과 3.20이하			±0.08
3.20초과 4.00이하	±0.05	±0.08	±0.10
4.00초과 6.00이하			±0.13
6.00 초과하는 것	±0.06	±0.10	±0.13

3

“ / ”

5.3

(1)

4

(2)

10.8

4

4

공칭 선 지름 (mm)	공칭 단면적 (mm ²)	단위 길이당 무게 (kg/m)	단위 길이당 무게의 허용차(%)
4	12.6	0.099	± 9
5	19.6	0.154	
6	28.3	0.222	
7	38.5	0.302	± 8
8	50.3	0.395	
9	63.6	0.499	
10	78.5	0.617	± 5
11	95	0.746	
12	113.1	0.888	
13	132.7	1.042	
14	153.9	1.208	
15	176.7	1.387	
16	201.1	1.579	

6. 표면 상태

SWM-F

6)

7. 겉 모양

SWM-A

8. 재료

KS D 3554

6)

가

9. 제조 방법

- (1) 가 1.8
mm
- (3) 가

10. 시험

10.1

- (1) ,
1
- (2) KS B 0801 4 9B

10.2

- (1) KS B 0802
- (2) 10.1(2)
5
- (3)

10.3

- 160~180 ° 3

1 (, 0.2% ,)

종 류	SWM-B	SWM-F	SWM-N	SWM-A		SWM-P		SWM-I,SWM-R		
품 특 성 질 명								0.2%		
선 지 름 또는 공 선 지 름 (mm)	<i>N/mm²</i>	<i>N/mm²</i>	<i>N/mm²</i>	<i>N/mm²</i>		<i>N/mm²</i>	%	<i>N/mm²</i>	<i>N/mm²</i>	%
0.1-1.3	-	-	/			/	/	/	/	/
1.4-1.8										
1.80	590 - 1270	320 - 1270	740 - 1270	260 - 590	61	540	30	440	540	8
2.00					55					
2.30					48					
2.60	42									
2.90	36									
3.20	33									
3.50	440 - 1030		590 - 1270		30					
4.00			27							
4.50			24							
5.00	390 - 930		540 930		22					
5.50			20							
6.00			17							
6.50			14							
7.00			/		11					
7.50			/							
8.0-16.0	320 - 880		/		-			/	/	/
16.0-18.0			/					/	/	/
용 도										

1. 1

2. 1 - " / "

부록 IV. 프로그램 매뉴얼

제
일
트
리
스
데
크

구
조
설
계
편
람

社團
法
大
韓
建
築
學
會